

**Sierra Series 220 and 221
Innova-Flo™ Vortex Flow Meters**

Instruction Manual

Part Number IM-220/221 with HART
August 2006



CORPORATE HEADQUARTERS

5 Harris Court, Building L Monterey, CA 93940
Phone (831) 373-0200 (800) 866-0200 Fax (831) 373-4402
www.sierrainstruments.com

EUROPE HEADQUARTERS

Bijlmansweid 2 1934RE Egmond a/d Hoef The Netherlands
Phone +31 72 5071400 Fax +31 72 5071401

ASIA HEADQUARTERS

Tomson Centre, Rm. A618, 188 Zhang Yang Road
Pu Dong New District, Shanghai, P.R.China
Phone: + 8621 5879 8521 Fax: +8621 5879 8586

Customer Notice

Unless you have specifically ordered Sierra's optional O₂ cleaning, this flow meter may not be fit for oxygen service. Sierra Instruments, Inc., is not liable for any damage or personal injury, whatsoever, resulting from the use of Sierra Instruments standard mass flow meters for oxygen gas. You are responsible for cleaning the mass flow meter to the degree required for your oxygen flow application.

© COPYRIGHT SIERRA INSTRUMENTS 1997

No part of this publication may be copied or distributed, transmitted, transcribed, stored in a retrieval system, or translated into any human or computer language, in any form or by any means, electronic, mechanical, manual, or otherwise, or disclosed to third parties without the express written permission of Sierra Instruments. The information contained in this manual is subject to change without notice.

TRADEMARKS

Innova-Flo™ is a trademark of Sierra Instruments, Inc. Other product and company names listed in this manual are trademarks or trade names of their respective manufacturers.

Table of Contents

Chapter 1 Introduction

Innova-Flo™ Vortex Flow Meters	1-1
Using this Manual.....	1-1
Note and Safety Information.....	1-2
Receipt of System Components	1-2
Technical Assistance	1-2
How the Innova-Flo Vortex Flow Meter Operates	1-3
Velocity Measurement/Pressure Drop.....	1-3
Flow Meter Configurations	1-7

Chapter 2 Installation

Installation Overview	2-1
Flow Meter Installation Requirements	2-1
Unobstructed Flow Requirements	2-2
Series 220 In-Line Flow Meter Installation.....	2-3
Wafer-Style Flow Meter Installation.....	2-4
Flange-Style Flow Meter Installation	2-5
Series 221 Insertion Flow Meter Installation.....	2-6
Cold Tap Guidelines	2-7
Hot Tap Guidelines	2-8
Flow Meter Insertion.....	2-9
Installing Meters with a Compression Connection.....	2-10
Installing Meters with a Packing Gland Connection	2-12
Installing Meters (Packing Gland), No Insertion Tool.....	2-15
Adjusting Meter Orientation.....	2-17
Display/Keypad Adjustment	2-17
Enclosure Adjustment	2-18
Wiring Connections	2-19
Input Power Connections	2-19
Pulse Output Connections.....	2-21
Remote Electronics Wiring	2-22

Chapter 3 Operating Instructions

Flow Meter Display/Keypad.....	3-1
Start Up.....	3-2
Using the Setup Menus	3-3
Programming the Flow Meter	3-3
Output Menu	3-4
Display Menu	3-5
Totalizer Menu	3-6
Units Menu	3-7
Diagnostics Menu	3-8
Calibration Menu	3-9

Password Menu.....	3-10
--------------------	------

Chapter 4 HART Communications

Wiring	4-1
HART Menus	4-2
Fast Key Sequence	4-3
Fast Key Sequence (continued)	4-4

Chapter 5 Troubleshooting and Repair

Hidden Diagnostics Menus	5-1
Column One Hidden Diagnostics Values	5-2
Column Two Hidden Diagnostic s Values.....	5-3
Analog Output Calibration	5-4
Troubleshooting the Flow Meter.....	5-4
Symptom: Output at no Flow.....	5-4
Symptom: Erratic Output	5-4
Symptom: No Output.....	5-5
Electronics Assembly Replacement.....	5-6
Returning Equipment to the Factory	5-7

Appendix A Product Specifications

Appendix B Glossary

Warnings and Cautions



Warning!

Agency approval for hazardous location installations varies between flow meter models. Consult the factory for specific flow meter approvals before any hazardous location installation. For explosion proof installations, you must use solid metal conduit and follow NFPA (or your local code) approved wiring methods.

Hot tapping must be performed by a trained professional. U.S. regulations often require a hot tap permit. The manufacturer of the hot tap equipment and/or the contractor performing the hot tap is responsible for providing proof of such a permit.

All flow meter connections, isolation valves and fittings for cold/hot tapping must have the same or higher pressure rating as the main pipeline.

For Series 221 insertion flow meter installations, an insertion tool must be used for any installation where a flow meter is inserted under pressure greater than 50 psig.

To avoid serious injury, DO NOT loosen a compression fitting under pressure.

All wiring procedures must be performed with the power Off.

Before attempting any flow meter repair, verify that the line is de-pressurized.

Always remove main power before disassembling any part of the mass flow meter.



Caution!

Calibration must be performed by qualified personnel. Sierra Instruments, Inc., strongly recommends that you return your flow meter to the factory for calibration.

In order to achieve accurate and repeatable performance, the flow meter must be installed with the specified minimum length of straight pipe upstream and downstream of the flow meter's sensor head.

When using toxic or corrosive gases, purge the line with inert gas for a minimum of four hours at full gas flow before installing the flow meter.

Wafer-style flow meter gaskets must be carefully aligned to ensure accurate flow measurement.

For Series 221 insertion flow meter installations, the sensor alignment pointer must point downstream in the direction of flow.

Chapter 1 Introduction

Innova-Flo™ Vortex Flow Meters

The Sierra Instruments' Series 220 In-Line and the Series 221 Insertion Innova-Flo™ Vortex Flow Meters provide a reliable solution for process flow measurement. From a single entry point in the pipeline, Innova-Flo meters offer precise measurements of mass or volumetric flow. The velocity sensor reduces the effects of pipeline vibration by incorporating a unique piezoelectric element that senses the vortex frequency. To extend rangeability at the low end of flow, the meter's smart electronics calculates the Reynolds number (Re) based on constant values of fluid density and viscosity stored in memory and automatically corrects for any non-linearity down to $Re = 5,000$.

Innova-Flo digital electronics allows reconfiguration for most gases, liquids and steam. The instrument is loop powered (12 to 36 VDC) with two output signals. The pulse output signal is proportional to volumetric flow rate; the analog linear 4-20 mA signal offers your choice of volumetric flow rate or mass flow rate. The mass flow rate is based on a constant value for fluid density stored in the instrument's memory. The local keypad/display provides instantaneous flow rate in engineering units or totalized flow.

The Sierra Series 220 and 221 Innova-Flo Meters simple installation combines with an easy-to-use interface that provides quick set up, long term reliability and accurate flow measurement over a wide range of flows and conditions.

Using This Manual

This manual provides the information needed to install and operate the Series 220 In-Line and Series 221 Insertion Innova-Flo Vortex Flow Meters. The four chapters of this manual cover these areas:

- Chapter 1 includes the introduction and product description
- Chapter 2 provides information needed for installation
- Chapter 3 describes system operation and programming
- Chapter 4 covers troubleshooting and repair

The product specifications are found in Appendix A. Appendix B contains a glossary of terms.

Note and Safety Information

We use note, caution and warning statements throughout this book to draw your attention to important information.



Warning!

This statement appears with information that is important to protect people and equipment from damage. Pay very close attention to all warnings that apply to your application.



Caution!

This statement appears with information that is important for protecting your equipment and performance. Read and follow all cautions that apply to your application.



Note

This statement appears with a short message to alert you to an important detail.

Receipt of System Components

When receiving a Sierra flow meter, carefully check the outside packing carton for damage incurred in shipment. If the carton is damaged, notify the local carrier and submit a report to the factory or distributor. Remove the packing slip and check that all ordered components are present. Make sure any spare parts or accessories are not discarded with the packing material. Do not return any equipment to the factory without first contacting Sierra Customer Service.

Technical Assistance

If you encounter a problem with your flow meter, review the configuration information for each step of the installation, operation and set up procedures. Verify that your settings and adjustments are consistent with factory recommendations. Refer to Chapter 4, Troubleshooting, for specific information and recommendations.

If the problem persists after following the troubleshooting procedures outlined in Chapter 4, contact Sierra Instruments, Technical Support at (800) 866-0200 or (831) 373-0200 between 8:00 a.m. and 5:00 p.m. PST. When calling Technical Support, have the following information on hand:

- the flow range, serial number and Sierra order number (all marked on the meter nameplate)
- the problem you are encountering and any corrective action taken
- application information (gas, pressure, temperature and piping configuration)

How the Innova-Flo Vortex Flow Meter Operates

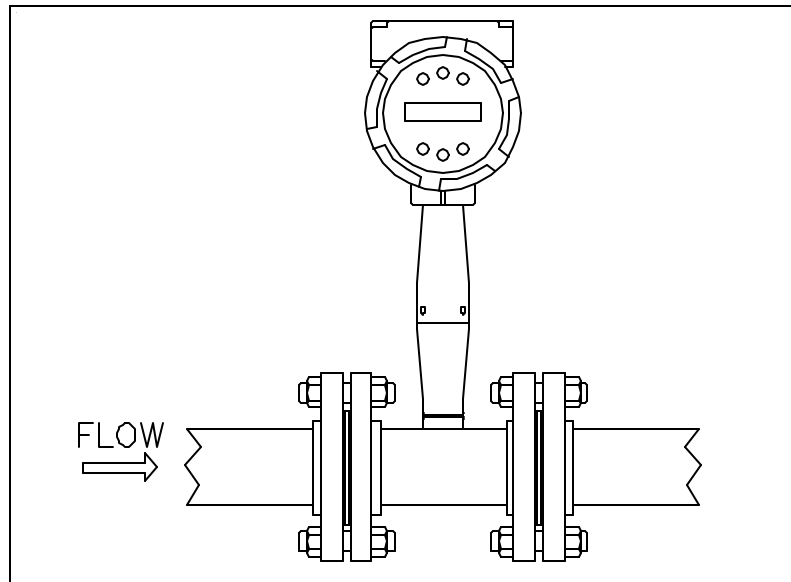

Figure 1-1. Series 220 In-Line Vortex Flow Meter

Sierra Series 220 and 221 Innova-Flo™ Vortex Flow Meters use a unique velocity sensor head to monitor volumetric flow rate. The built-in flow computer calculates mass flow rate based on a constant value of fluid density stored in the instrument's memory. To measure fluid velocity, the flow meter incorporates a bluff body (shedder bar) in the flow stream, and the velocity sensor measures the frequency of vortices created by the shedder bar. The velocity sensor head is located downstream of the shedder bar within the flow body.

Velocity Measurement

The Innova-Flo vortex velocity sensor is a patented mechanical design that minimizes the effects of pipeline vibration and pump noise, both of which are common error sources in flow measurement with vortex flow meters. The velocity measurement is based on the well-known Von Karman vortex shedding phenomenon. Vortices are shed from a shedder bar, and the vortex velocity sensor located downstream of the shedder bar senses the passage of these vortices. This method of velocity measurement has many advantages including inherent linearity, high turndown, reliability and simplicity.

Vortex Shedding Frequency

Von Karman vortices form downstream of a shedder bar into two distinct wakes. The vortices of one wake rotate clockwise while those of the other wake rotate counterclockwise. Vortices generate one at a time, alternating from the left side to the right side of the shedder bar. Vortices interact with their surrounding space by over-powering every other nearby swirl on the verge of development. Close to the shedder bar, the distance (or wave length) between vortices is always constant and measurable. Therefore, the volume encompassed by each vortex remains constant, as shown below. By sensing the number of vortices passing by the velocity sensor, the Innova-Flo™ Vortex Flow Meter computes the total fluid volume.

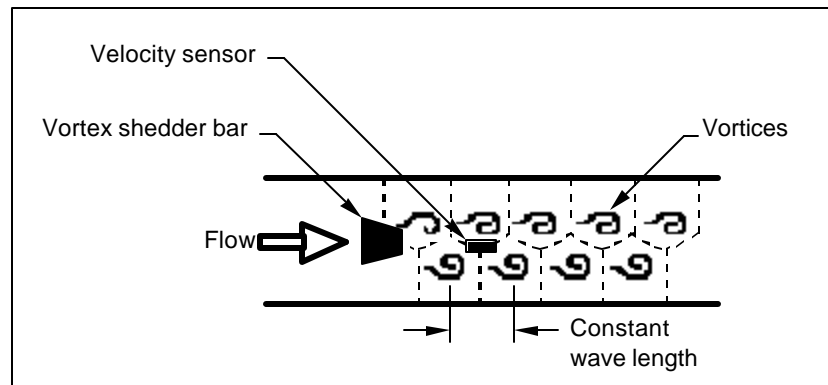

Figure 1-2. Measurement Principle of Vortex Flow Meters

Vortex Frequency Sensing

The velocity sensor incorporates a piezoelectric element that senses the vortex frequency. This element detects the alternating lift forces produced by the Von Karman vortices flowing downstream of the vortex shedder bar. The alternating electric charge generated by the piezoelectric element is processed by the transmitter's electronic circuit to obtain the vortex shedding frequency. The piezoelectric element is highly sensitive and operates over a wide range of flows, pressures and temperatures.

Flow Velocity Range

To ensure trouble-free operation, vortex flow meters must be correctly sized so that the flow velocity range through the meter lies within the measurable velocity range (with acceptable pressure drop) and the linear range.

The measurable range is defined by the minimum and maximum velocity using the following table.

	Gas	Liquid	
Vmin	$\sqrt{\frac{25}{r}}$ ft/s	1 ft/s	English r (lb/ft ³)
Vmax	300 ft/s	30 ft/s	
Vmin	$\sqrt{\frac{37}{r}}$ m/s	0.3 m/s	Metric r (kg/m ³)
Vmax	91 m/s	9.1 m/s	

The **pressure drop** for series 221 insertion meters is negligible. The pressure drop for series 220 in-line meters is defined as:

$$\Delta P = .00024 \rho V^2 \quad \text{English units } (\Delta P \text{ in psi, } \rho \text{ in lb/ft}^3, V \text{ in ft/sec})$$

$$\Delta P = .000011 \rho V^2 \quad \text{Metric units } (\Delta P \text{ in bar, } \rho \text{ in kg/m}^3, V \text{ in m/sec})$$

The linear range is defined by the Reynolds number. The Reynolds number is the ratio of the inertial forces to the viscous forces in a flowing fluid and is defined as:

$$Re = \frac{\rho V D}{\mu}$$

Where

Re = Reynolds Number

ρ = mass density of the fluid being measured

V = velocity of the fluid being measured

D = internal diameter of the flow channel

μ = viscosity of the fluid being measured

The Strouhal number is the other dimensionless number that quantifies the vortex phenomenon. The Strouhal number is defined as:

$$St = \frac{f d}{V}$$

Where

St = Strouhal Number

f = frequency of vortex shedding

d = shedder bar width

V = fluid velocity

As shown below, Innova-Flo™ Vortex Flow Meters exhibit a constant Strouhal number across a large range of Reynolds numbers, indicating a consistent linear output over a wide range of flows and fluid types. Below this linear range, the intelligent electronics in Innova-Flo automatically corrects for the variation in the Strouhal number. Innova-Flo's smart electronics correct for this non-linearity by calculating the Reynolds number based on constant values of the fluid's density and viscosity stored in the instrument's memory. Innova-Flo Vortex Flow Meters automatically correct down to a Reynolds number of 5,000.

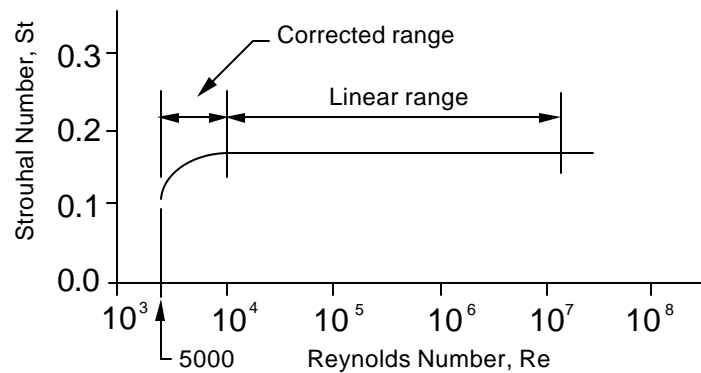

Figure 1-3. Reynolds Number Range for the Innova-Flo Meter

Flow Meter Configurations

Innova-Flo™ Vortex Flow Meters are available in two configurations:

- Series 220 in-line flow meter (replaces a section of the pipeline)
- Series 221 insertion flow meter (requires a “cold” tap or a “hot” tap into an existing pipeline)

Both the in-line and insertion configurations are similar in that they both use identical electronics and have similar sensor heads. Besides installation differences, the main difference between an in-line flow meter and an insertion flow meter is their method of measurement.

For an in-line vortex flow meter, the shedder bar is located across the entire diameter of the flow body. Thus, the entire pipeline flow is included in the vortex formation and measurement. The sensing head, which directly measures velocity is located just downstream of the shedder bar.

An insertion vortex flow meter has its sensing head at the end of a 0.750 inch diameter tubular stem. The stem is inserted into the pipe until the sensing head is properly located in the pipe’s cross section. The sensing head fits through any entry port with an 1.875 inch minimum internal diameter.

The sensing head of an insertion vortex flow meter directly monitors the velocity at a point in the cross-sectional area of a pipe, duct, or stack (referred to as “channels”). The velocity at a point in the pipe varies as a function of the Reynolds number. The insertion vortex flow meter computes the Reynolds number based on constant values of the fluid’s density and viscosity stored in its memory and then computes the total flow rate in the channel. The output signal of insertion meters is the total flow rate in the channel. The accuracy of the total flow rate computation depends on adherence to the piping installation requirements given in Chapter 2. If adherence to those guidelines cannot be met, contact the factory for specific installation advice.

Flow Meter Electronics

Innova-Flo electronics are available mounted directly to the flow body, or remotely mounted. The electronics housing may be used indoors or outdoors, including wet environments. The instrument requires 4-20 mA loop power (12 to 36 VDC). One analog output signal is available for your choice of volumetric flow rate or mass flow rate. A pulse output is available for totalization.

The meter includes a local 2 x 16 character LCD display housed within the enclosure. Local operation and reconfiguration is accomplished using six push buttons. For hazardous locations, the six push buttons can be operated through the sealed enclosure using a hand-held magnet, thereby not compromising the integrity of the hazardous location certification.

The electronics include nonvolatile memory that stores all configuration information. The memory allows the flow meter to function immediately upon power up, or after an interruption in power.

Chapter 2 Installation

Installation Overview

Innova-Flo™ meter installations are simple and straightforward. Both the Series 220 In-Line and Series 221 Insertion type flow meter installations are covered in this chapter. After reviewing the installation requirements given below, see page 2-3 for Series 220 installation instructions. See page 2-6 for Series 221 installation instructions. Wiring instructions begin on page 2-19.

Flow Meter Installation Requirements

Before installing the flow meter, verify the installation site allows for these considerations:



Warning!

Consult the flow meter nameplate for specific flow meter approvals before any hazardous location installation.

1. Line pressure and temperature will not exceed the flow meter rating.
2. The location meets the required minimum number of pipe diameters upstream and downstream of the sensor head as illustrated Figure 2-1.
3. Safe and convenient access with adequate overhead clearance for maintenance purposes.
4. Verify that the cable entry into the instrument meets the specific standard required for hazardous area installations.
5. For remote installations, verify the supplied cable length is sufficient to connect the flow meter sensor to the remote electronics.

Also, before installation check your flow system for anomalies such as:

- leaks
- valves or restrictions in the flow path that could create disturbances in the flow profile that might cause unexpected flow rate indications

Unobstructed Flow Requirements

Select an installation site that will minimize possible distortion in the flow profile. Valves, elbows, control valves and other piping components may cause flow disturbances. Check your specific piping condition against the examples shown below. In order to achieve accurate and repeatable performance install the flow meter using the recommended number of straight run pipe diameters upstream and downstream of the sensor.

Note: For liquid applications in vertical pipes, avoid installing with flow in the downward direction because the pipe may not be full at all points. Choose to install the meter with flow in the upward direction if possible.

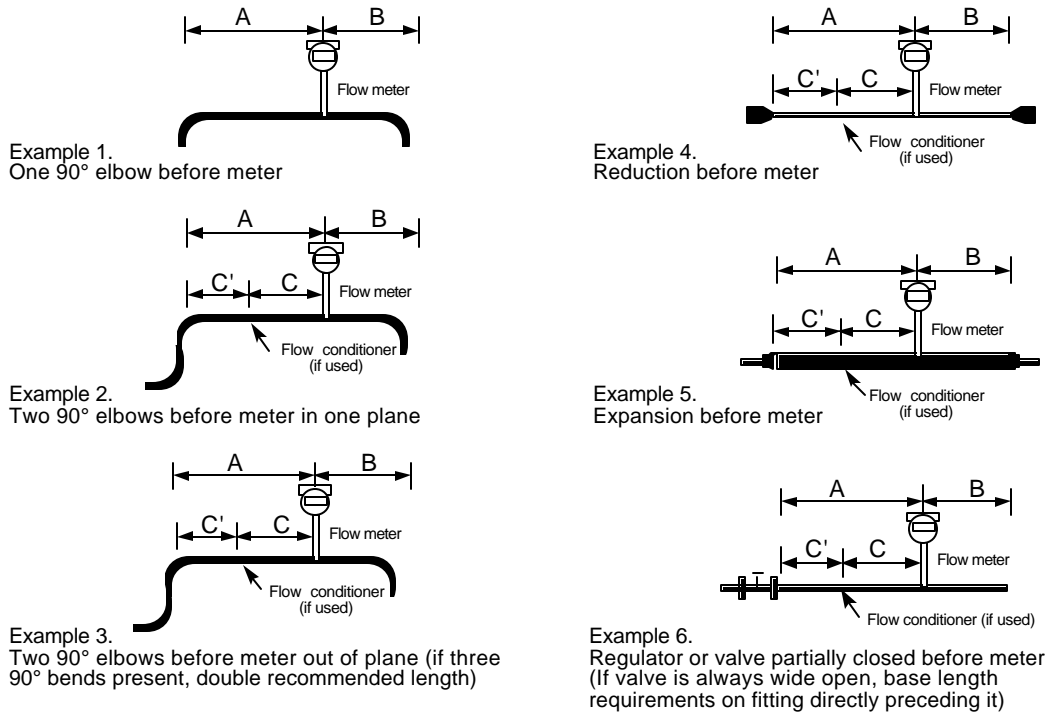

Example	Minimum Required Upstream Diameters				Minimum Required Downstream Diameters	
	No Flow Conditioner	With Flow Conditioner			No Flow Conditioner	With Flow Conditioner
	A	A	C	C'	B	B
1	10 D	N/A	N/A	N/A	5 D	5 D
2	15 D	10 D	5 D	5 D	5 D	5 D
3	25 D	10 D	5 D	5 D	10 D	5 D
4	10 D	10 D	5 D	5 D	5 D	5 D
5	20 D	10 D	5 D	5 D	5 D	5 D
6	25 D	10 D	5 D	5 D	10 D	5 D

D = Internal diameter of channel. N/A = Not applicable

Figure 2-1. Recommended Pipe Length Requirements for Installation, Series 220 and 221

Series 220 In-Line Flow Meter Installation

Install the Series 220 In-Line Flow Meter between two conventional pipe flanges as shown in Figures 2-3 and 2-4. Table 2-1 provides the recommended minimum stud bolt lengths for wafer-style meter body size and different flange ratings.

The meter inside diameter is equal to the same size nominal pipe ID in schedule 80. For example, a 2" meter has an ID of 1.939" (2" schedule 80). **Do not install the meter in a pipe with an inside diameter smaller than the inside diameter of the meter.** For schedule 160 and higher pipe, a special meter is required. Consult the factory before purchasing the meter.

Series 220 Meters require customer-supplied gaskets. When selecting gasket material make sure that it is compatible with the process fluid and pressure ratings of the specific installation. Verify that the inside diameter of the gasket is larger than the inside diameter of the flow meter and adjacent piping. If the gasket material extends into the flow stream, it will disturb the flow and cause inaccurate measurements.

Flange Bolt Specifications

Stud Bolt Lengths for Each Flange Rating (inches)			
Line Size	Class 150	Class 300	Class 600
1 inch	6.00	7.00	7.50
1.5 inch	6.25	8.50	9.00
2 inch	8.50	8.75	9.50
3 inch	9.00	10.00	10.50
4 inch	9.50	10.75	12.25

Table 2-1. Minimum Recommended Stud Bolt Lengths for Wafer Meters

The required bolt load for sealing the gasket joint is affected by several application-dependent factors, therefore the required torque for each application may be different. Refer to the ASME Pressure Vessel Code guidelines for bolt tightening standards.

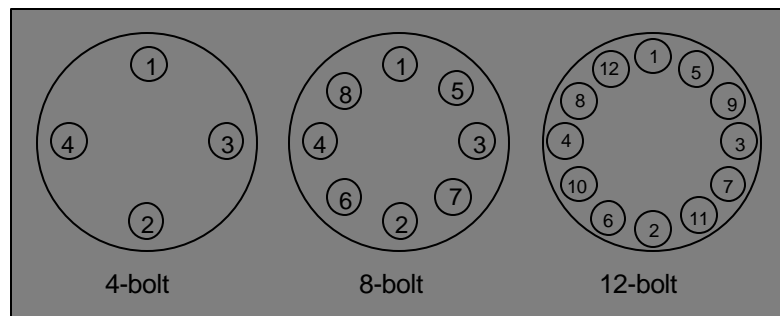

Figure 2-2. Flange Bolt Torquing Sequence

Wafer-Style Flow Meter Installation

Install the wafer-style meter between two conventional pipe flanges of the same nominal size as the flow meter. If the process fluid is a liquid, make sure the meter is located where the pipe is always full. This may require locating the meter at a low point in the piping system. Note: Vortex flow meters are not suitable for two-phase flows (i.e., liquid and gas mixtures). For horizontal pipelines having a process temperature above 300° F, mount the meter at a 45 or 90-degree angle to avoid overheating the electronics enclosure. To adjust the viewing angle of the enclosure or display/keypad, see page 2-17.

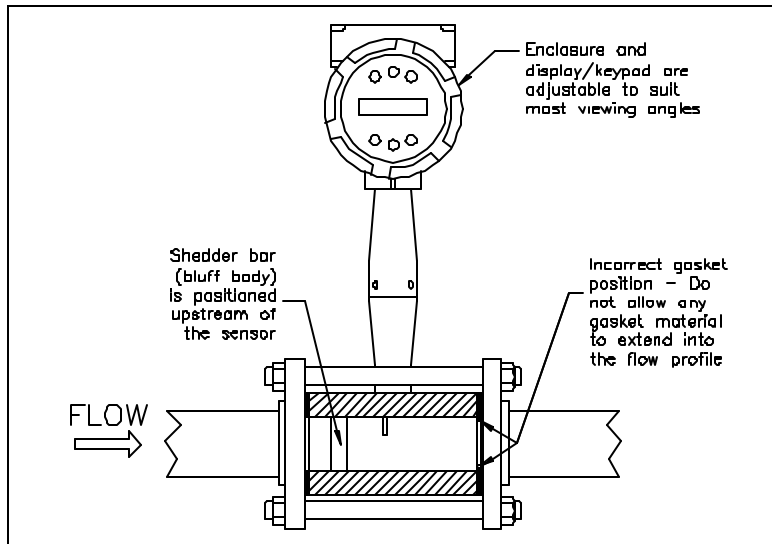

Figure 2-3. Wafer-Style Flow Meter Installation

When installing the meter make sure the section marked “inlet” is positioned upstream of the outlet, facing the flow. This ensures that the sensor head is positioned downstream of the vortex shedder bar and is correctly aligned to the flow. Installing the meter opposite this direction will result in completely inaccurate flow measurement. To install the meter:

1. Turn off the flow of process gas, liquid or steam. Verify that the line is not pressurized. Confirm that the installation site meets the required minimum upstream and downstream pipe diameters.
2. Insert the studs for the bottom side of the meter body between the pipe flanges. Place the wafer-style meter body between the flanges with the end stamped “inlet” facing flow. Center the meter body inside the diameter with respect to the inside diameter of the adjoining piping.
3. Position the gasket material between the mating surfaces. Make sure both gaskets are smooth and even with no gasket material extending into the flow profile. Obstructions in the pipeline will disturb the flow and cause inaccurate measurements.
4. Place the remaining studs between the pipe flanges. Tighten the nuts in the sequence shown in Figure 2-2. Check for leaks after tightening the flange bolts.



Caution!

When using toxic or corrosive gases, purge the line with inert gas for a minimum of four hours at full gas flow before installing the flow meter.

Flange-Style Flow Meter Installation

Install the flange-style meter between two conventional pipe flanges of the same nominal size as the flow meter. If the process fluid is a liquid, make sure the meter is located where the pipe is always full. This may require locating the meter at a low point in the piping system. Note: Vortex flow meters are not suitable for two-phase flows (i.e., liquid and gas mixtures). For horizontal pipelines having a process temperature above 300° F, mount the meter at a 45 or 90-degree angle to avoid overheating the electronics enclosure. To adjust the viewing angle of the enclosure or display/keypad, see page 2-17.

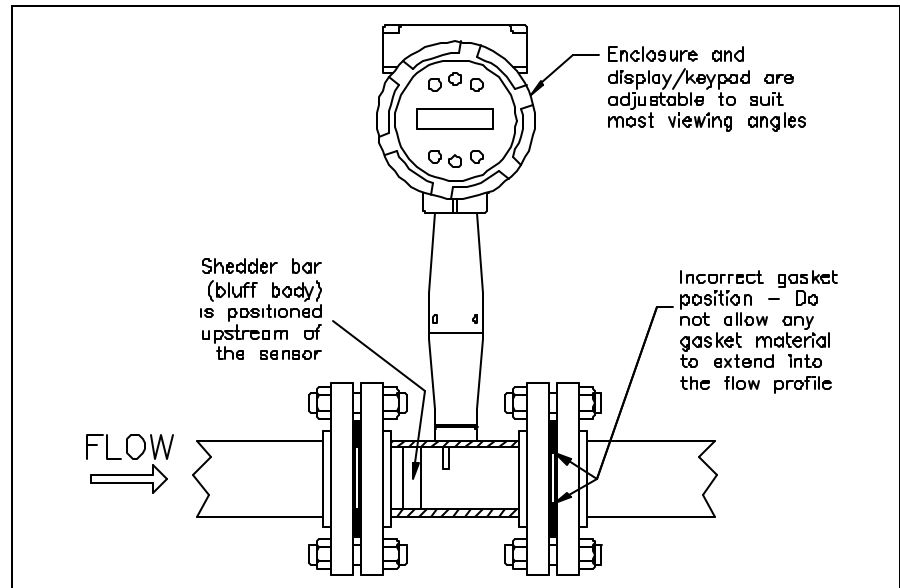

Figure 2-4. Flange-Style Flow Meter Installation



Caution!

When using toxic or corrosive gases, purge the line with inert gas for a minimum of four hours at full gas flow before installing the flow meter.

When installing the meter make sure the flange marked “inlet” is positioned upstream of the outlet flange, facing the flow. This ensures that the sensor head is positioned downstream of the vortex shedder bar and is correctly aligned to the flow. Installing the meter opposite this direction will result in completely inaccurate flow measurement. To install the meter:

1. Turn off the flow of process gas, liquid or steam. Verify that the line is not pressurized. Confirm that the installation site meets the required minimum upstream and downstream pipe diameters.
2. Seat the meter level and square on the mating connections with the flange marked “inlet” facing the flow. Position a gasket in place for each side. Make sure both gaskets are smooth and even with no gasket material extending into the flow profile. Obstructions in the pipeline will disturb the flow and cause inaccurate measurements.
3. Install bolts in both process connections. Tighten the nuts in the sequence shown in Figure 2-2. Check for leaks after tightening the flange bolts.

Series 221 Insertion Flow Meter Installation

Prepare the pipeline for installation using either a cold tap or hot tap method described on the following pages. Refer to a standard code for all pipe tapping operations. The following tapping instructions are general in nature and intended for guideline purposes only. Before installing the meter, review the mounting position and isolation valve requirements given below.

Mounting Position

Allow clearance between the electronics enclosure top and any other obstruction when the meter is fully retracted.

Isolation Valve Selection

An isolation valve is available as an option with Series 221 meters. If you supply the isolation valve, it must meet the following requirements:

1. A minimum valve bore diameter of 1.875 inches is required, and the valve's body size should be two inches. Normally, gate valves are used.
2. Verify that the valve's body and flange rating are within the flow meter's maximum operating pressure and temperature.
3. Choose an isolation valve with at least two inches existing between the flange face and the gate portion of the valve. This ensures that the flow meter's sensor head will not interfere with the operation of the isolation valve.

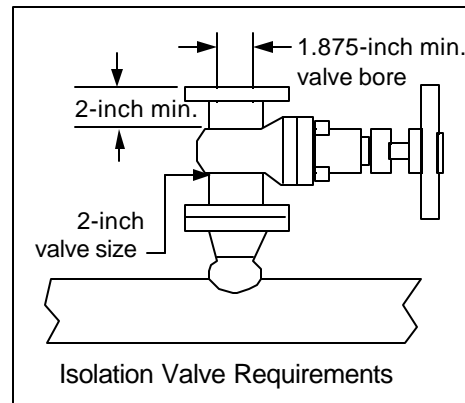

Cold Tap Guidelines

Refer to a standard code for all pipe tapping operations. The following tapping instructions are general in nature and intended for guideline purposes only.



Caution!

When using toxic or corrosive gases, purge the line with inert gas for a minimum of four hours at full gas flow before installing the

1. Turn off the flow of process gas, liquid or steam. Verify that the line is not pressurized.
2. Confirm that the installation site meets the minimum upstream and downstream pipe diameter requirements. See Figure 2-1.
3. Use a cutting torch or sharp cutting tool to tap into the pipe. The pipe opening must be at least 1.875 inches in diameter. (Do not attempt to insert the sensor probe through a smaller hole.)
4. Remove all burrs from the tap. Rough edges may cause flow profile distortions that could affect flow meter accuracy. Also, obstructions could damage the sensor assembly when inserting into the pipe.
5. After cutting, measure the thickness of the cut-out and record this number for calculating the insertion depth.



Warning!

All flow meter connections, isolation valves and fittings for cold tapping must have the same or higher pressure rating as the main pipeline.

6. Weld the flow meter pipe connection on the pipe. Make sure this connection is within $\pm 5^\circ$ perpendicular to the pipe centerline.

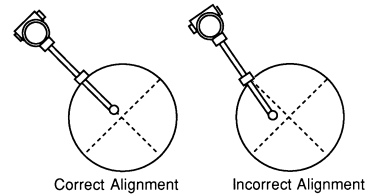

7. Install the isolation valve (if used).
8. When welding is complete and all fittings are installed, close the isolation valve or cap the line. Run a static pressure check on the welds. If pressure loss or leaks are detected, repair the joint and re-test.
9. Connect the meter to the pipe process connection.
10. Calculate the sensor probe insertion depth as described on the following pages. Insert the sensor probe into the pipe.

Hot Tap Guidelines



Warning!

Hot tapping must be performed by a trained professional. US. regulations often require a hot tap permit. The manufacturer of the hot tap equipment and/or the contractor performing the hot tap is responsible for providing proof of such a permit.



Warning!

All flow meter connections, isolation valves and fittings for hot tapping must have the same or higher pressure rating as the main

Refer to a standard code for all pipe tapping operations. The following tapping instructions are general in nature and intended for guideline purposes only.

1. Confirm that the installation site meets the minimum upstream and downstream pipe diameter requirements.
2. Weld a two inch mounting adapter on the pipe. Make sure the mounting adapter is within $\pm 5^\circ$ perpendicular to the pipe centerline (see previous page). The pipe opening must be at least 1.875 inches in diameter.
3. Connect a two inch process connection on the mounting adapter.
4. Connect an isolation valve on the process connection. The valve's full open bore must be at least 1.875 inches in diameter.
5. Hot tap the pipe.
6. Close the isolation valve. Run a static pressure check on the welds. If pressure loss or leaks are detected, repair the joint and re-test.
7. Connect the flow meter to the isolation valve.
8. Calculate the sensor probe insertion depth as described on the following pages. Insert the sensor probe assembly into the pipe.

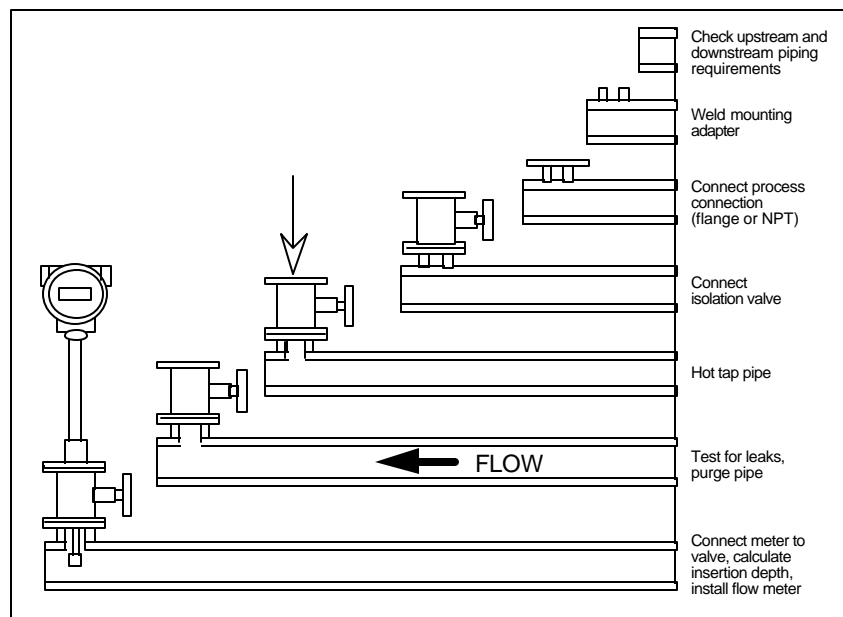

Figure 2-5. Hot Tap Sequence

Flow Meter Insertion

The sensor head must be properly positioned in the pipe. For this reason, it is important that insertion length calculations are carefully followed. A sensor probe inserted at the wrong depth in the pipe will result in inaccurate readings.

Insertion flow meters are applicable to pipes 2 inch and larger. For pipe sizes ten inches and smaller, the centerline of the meter's sensing head is located at the pipe's centerline. For pipe sizes larger than ten inches, the centerline of the sensing head is located in the pipe's cross section five inches from the inner wall of the pipe; i.e., its "wetted" depth from the wall to the centerline of the sensing head is five inches.

Insertion flow meters are available in three probe lengths:

Standard Probe configuration is used with most flow meter process connections. The length, *S*, of the stem is 29.47 inches.

Compact Probe configuration is used with compression fitting process connections. The length, *S*, of the stem is 13.1 inches.

12-Inch Extended Probe configuration is used with exceptionally lengthy flow meter process connections. The length, *S*, of the stem is 41.47 inches.

Use the Correct Insertion Formula

Depending on your flow meter's process connection, use the applicable insertion length formula and installation procedure as follows:

- Flow meters with a compression type connection (NPT or flanged) follow the instructions beginning on page 2-10.
- Flow meters with a packing gland type connection (NPT or flanged) configured with an insertion tool, follow the instructions beginning on page 2-12.
- Flow meters with a packing gland type connection (NPT or flanged) without an insertion tool, follow the instructions beginning on page 2-15.



Warning!

An insertion tool must be used for any installation where a flow meter is inserted under pressure greater than 50 psig.

Installing Flow Meters with a Compression Connection*

Use the following formula to determine insertion length for flow meters (NPT and flanged) with a compression process connection. The installation procedure is given on the next page.

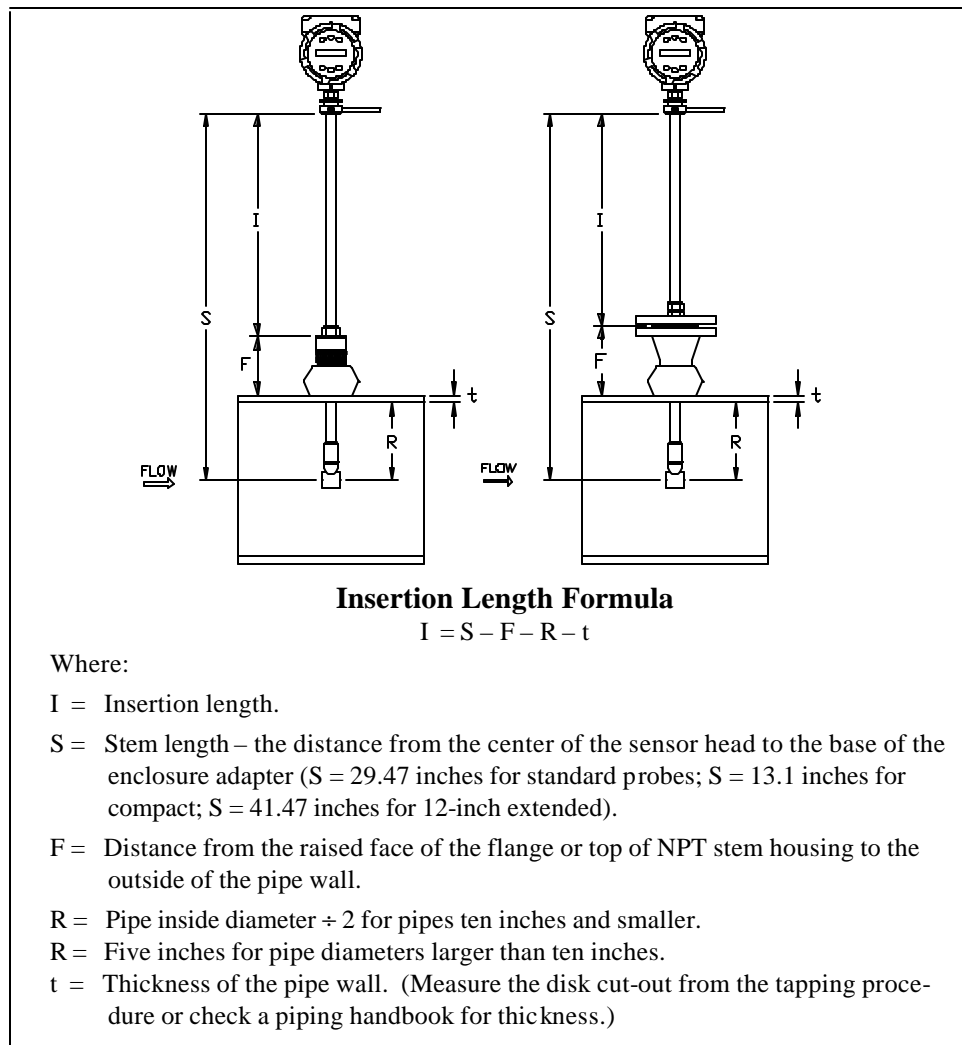

Figure 2-6. Insertion Calculation (Compression Type)

Example:

To install a Series 221 meter with a standard probe (S = 29.47 inches) into a 14 inch schedule 40 pipe, the following measurements are taken:

$$\begin{aligned} F &= 3 \text{ inches} \\ R &= 5 \text{ inches} \\ t &= 0.438 \text{ inches} \end{aligned}$$

The insertion length for this example is 21.03 inches. Insert the stem through the fitting until an insertion length of 21.03 inches is measured with a ruler.

*All dimensions are in inches

Insertion Procedure for Meters with a Compression Connection

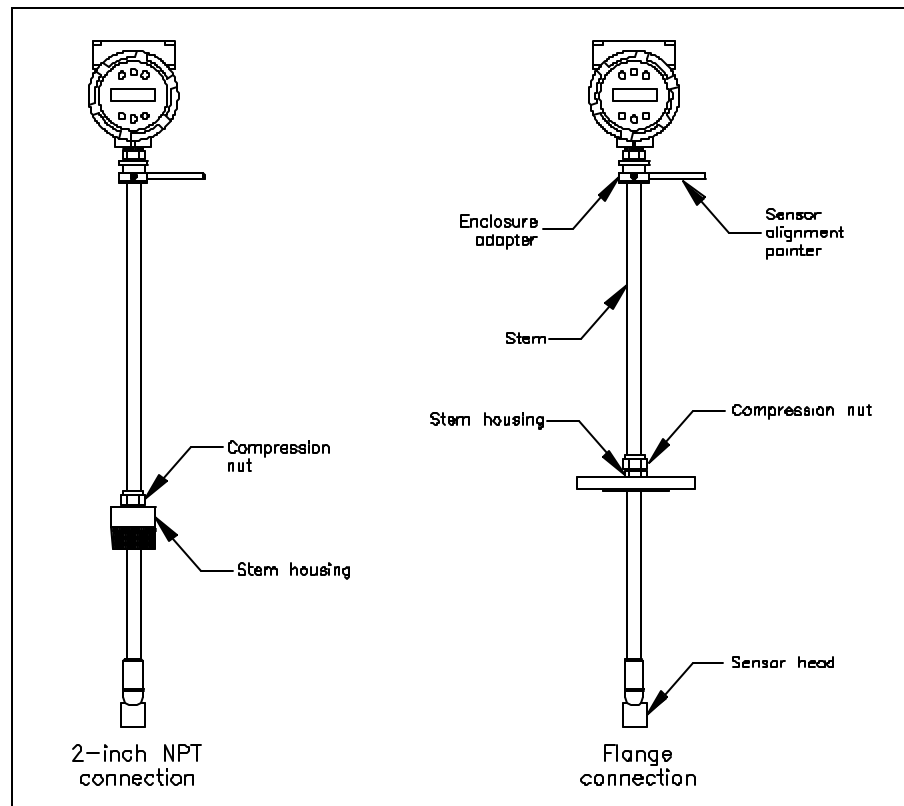

Figure 2-7. Flow Meter with Compression Type Fitting



Caution!

The sensor alignment pointer must point downstream, in the direction of flow.



Warning!

To avoid serious injury, DO NOT loosen the compression fitting under pressure.

1. Calculate the required sensor probe insertion length.
2. Fully retract the stem until the sensor head is touching the bottom of the stem housing. Slightly tighten the compression nut to prevent slippage.
3. Bolt or screw the flow meter assembly into the process connection. Use Teflon tape or pipe sealant to improve the seal and prevent seizing on NPT styles.
4. Hold the meter securely while loosening the compression fitting. Insert the sensor into the pipe until the calculated insertion length, I , is measured between the base of the enclosure adapter and the top of the stem housing, or to the raised face of the flanged version. Do not force the stem into the pipe.
5. Align the sensor head using the sensor alignment pointer. Adjust the alignment pointer parallel to the pipe and pointing downstream.
6. Tighten the compression fitting to lock the stem in position. **When the compression fitting is tightened, the position is permanent.**

Installing Flow Meters with a Packing Gland Connection*

Use the formula below to determine the insertion depth for flow meters (NPT and flanged) equipped with an insertion tool. To install, see the next page for instructions for meters with a permanent insertion tool. For meters with a removable insertion tool, see page 2-14.

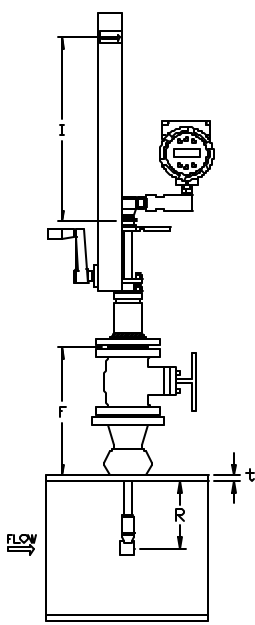

Insertion Length Formula

$$I = F + R + t - 1.35$$

Where:

I = Insertion length.

F = Distance from the raised face of the flange or top of the process connection for NPT style meters to the top outside of the process pipe.

R = Pipe inside diameter ÷ 2 for pipes ten inches & smaller.
R = Five inches for pipe diameters larger than ten inches.

t = Thickness of the pipe wall. (Measure the disk cut-out from the tapping procedure or check a piping handbook for thickness.)

Figure 2-8. Insertion Calculation (Meters with Insertion Tool)

Example 1: Flange Style Meters:

To install a Series 221 Flow Meter into a 14 inch schedule 40 pipe, the following measurements are taken:

$$\begin{aligned} F &= 12 \text{ inches} \\ R &= 5 \text{ inches} \\ t &= 0.438 \text{ inches} \end{aligned}$$

The example insertion length is 16.09 inches.

Example 2: NPT Style Meters:

The length of thread engagement on the NPT style meters is also subtracted in the equation. The length of the threaded portion of the NPT meter is 1.18 inches. Measure the thread portion still showing after the installation and subtract that amount from 1.18 inches. This gives you the thread engagement length. If this cannot be measured use .55 inch for this amount.

$$\begin{aligned} F &= 12 \text{ inches} \\ R &= 5 \text{ inches} \\ t &= 0.438 \text{ inches} \end{aligned}$$

The example insertion length is 15.54 inches.

*All dimensions are in inches.

Insertion Procedure for Flow Meters with Permanent Insertion Tool

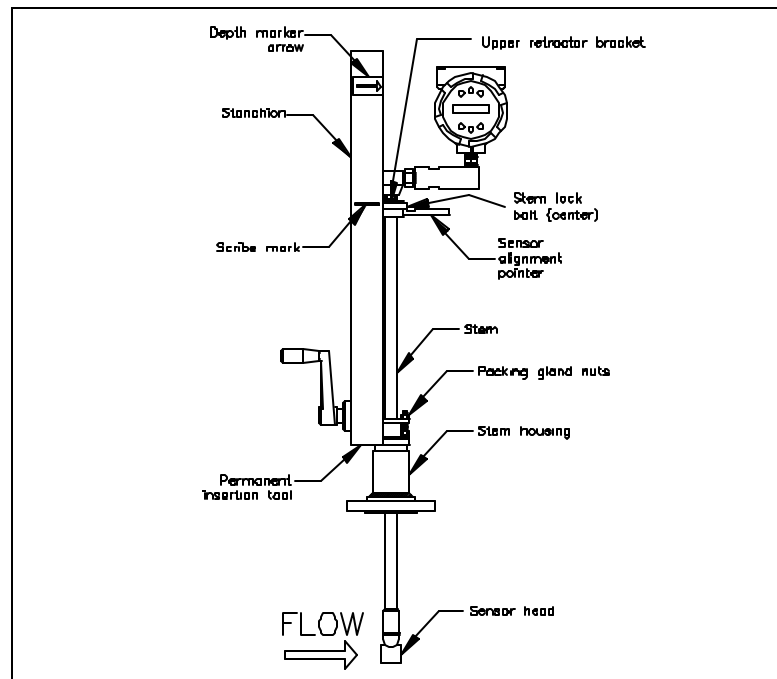

Figure 2-9. Flow Meter with Permanent Insertion Tool

1. Calculate the required sensor probe insertion length (see previous page). Measure from the depth marker arrow down the stanchion and scribe a mark at the calculated insertion depth.
2. Fully retract the flow meter until the sensor head is touching the bottom of the stem housing. Attach the meter assembly to the two inch full-port isolation valve, if used. Use Teflon tape or pipe sealant to improve seal and prevent seizing on NPT style.
3. Loosen the two packing gland nuts on the stem housing of the meter. Loosen the stem lock bolt adjacent to the sensor alignment pointer. Align the sensor head using the sensor alignment pointer. Adjust the alignment pointer parallel to the pipe and pointing downstream. Tighten the stem lock bolt to secure the sensor position.
4. Slowly open the isolation valve to the full open position. If necessary, slightly tighten the two packing gland nuts to reduce the leakage around the stem.
5. Turn the insertion tool handle clockwise to insert the sensor head into the pipe. Continue until the top of the upper retractor bracket aligns with the insertion length position scribed on the stanchion. Do not force the stem into the pipe.
6. Tighten the packing gland nuts to stop leakage around the stem. Do not torque over 20 ft-lb.



Caution!

The sensor alignment pointer must point downstream, in the direction of flow.



Note

If line pressure is above 500 psig, it could require up to 25 ft lb of torque to insert the flow meter. Do not confuse this with possible interference in the pipe.

Insertion Procedure for Flow Meters with Removable Insertion Tool

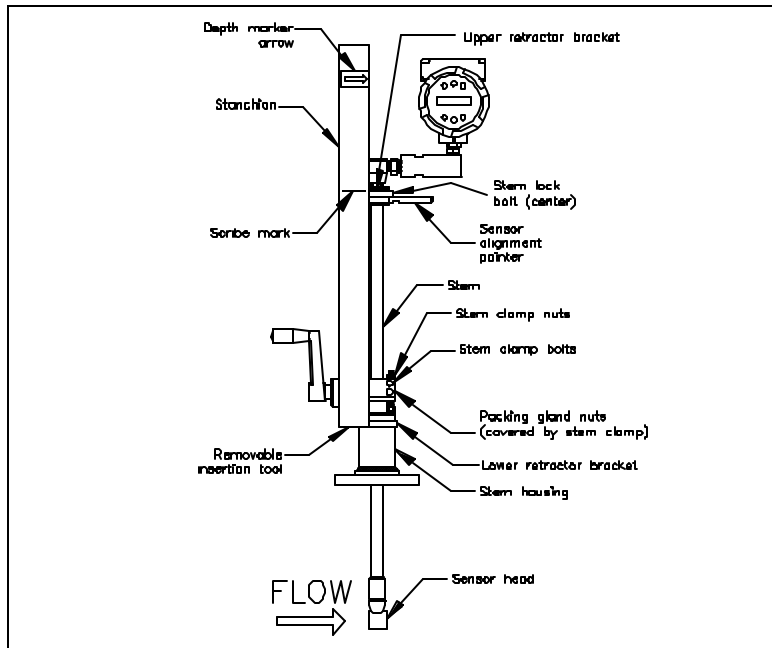

Figure 2-10. Flow Meter with Removable Insertion Tool

1. Calculate the required sensor probe insertion length. Measure from the depth marker arrow down the stanchion and scribe a mark at the calculated insertion depth.
2. Fully retract the flow meter until the sensor head is touching the bottom of the stem housing. Attach the meter assembly to the two inch full-port isolation valve, if used. Use Teflon tape or pipe sealant to improve seal and prevent seizing on NPT style.
3. Remove the two top stem clamp nuts and loosen two stem clamp bolts. Slide the stem clamp away to expose the packing gland nuts.
4. Loosen the two packing gland nuts. Loosen the stem lock bolt adjacent to the sensor alignment pointer. Align the sensor head using the sensor alignment pointer. Adjust the alignment pointer parallel to the pipe and pointing downstream. Tighten the stem lock bolt to secure the sensor position.
5. Slowly open the isolation valve to the full open position. If necessary, slightly tighten the two packing gland nuts to reduce the leakage around the stem.
6. Turn the insertion tool handle clockwise to insert the stem into the pipe. Continue until the top of the upper retractor bracket lines up with the insertion length mark scribed on the stanchion. Do not force the stem into the pipe.



Caution!

The sensor alignment pointer must point downstream, in the direction of flow.



Note

If line pressure is above 500 psig, it could require up to 25 ft lb of torque to insert the flow meter. Do not confuse this with possible interference in the pipe.

7. Tighten the packing gland nuts to stop leakage around the stem. Do not torque over 20 ft-lbs.
8. Slide the stem clamp back into position. Torque stem clamp bolts to 15 ft-lbs. Replace the stem clamp nuts and torque to 10-15 ft-lbs.
9. Attach the safety chain from the stem clamp to the hook on the enclosure adapter at the nearest link. To separate the insertion tool from the flow meter, remove four socket head cap bolts securing the upper and lower retractor brackets. Remove the insertion tool.

Installation of Meters with Packing Gland Connection (No Insertion Tool)*

Use the following formula to determine insertion depth for meters with a packing gland connection (NPT and flanged) without an insertion tool.

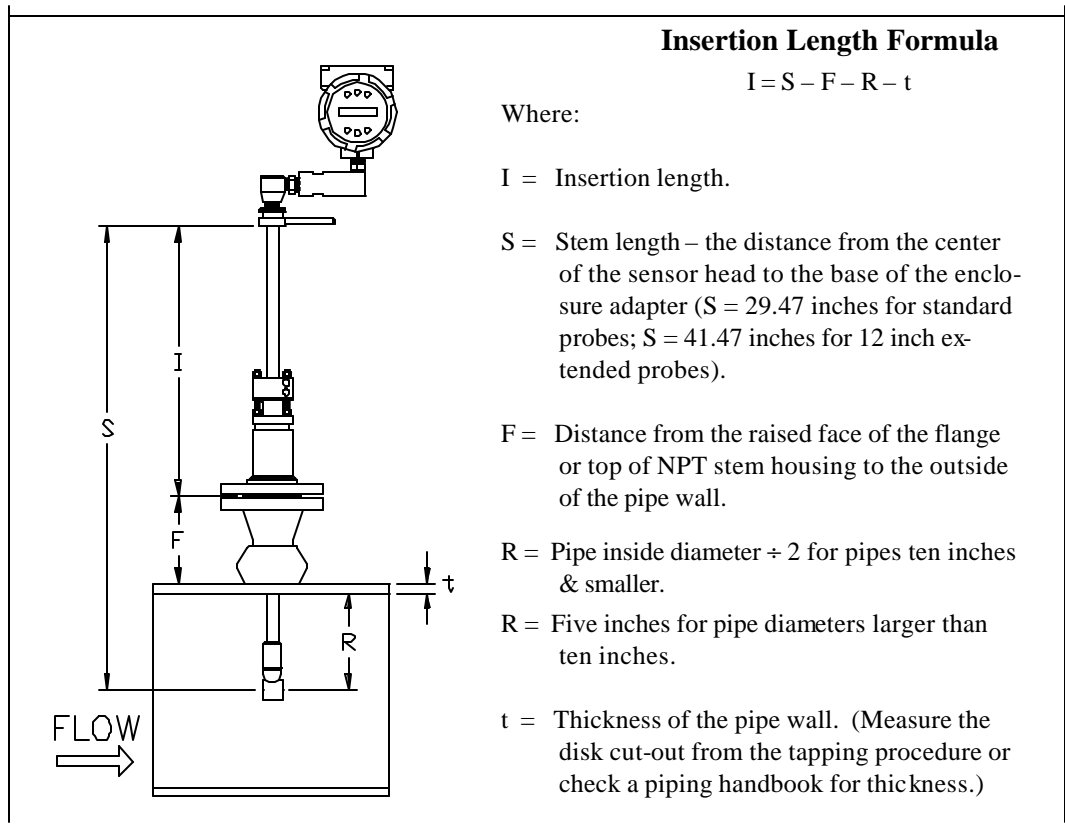

Figure 2-11. Insertion Calculation (Meters without Insertion Tool)

Example:

To install a Series 221 Flow Meter with a standard probe (S = 29.47) into a 14 inch schedule 40 pipe, the following measurements are taken:

$$\begin{aligned}
 F &= 3 \text{ inches} \\
 R &= 5 \text{ inches} \\
 t &= 0.438 \text{ inches}
 \end{aligned}$$

The example insertion length is 21.03 inches.

**All dimensions are in inches.*

Insertion Procedure for Flow Meters with No Insertion Tool (Packing Gland Connection)



Warning!

The line must be less than 50 psig for installation.



Caution!

The sensor alignment pointer must point downstream, in the direction of flow.

1. Calculate the required sensor probe insertion length.
2. Fully retract the stem until the sensor head is touching the bottom of the stem housing. Remove the two top stem clamp nuts and loosen two stem clamp bolts. Slide the stem clamp away to expose the packing gland nuts. Loosen the two packing gland nuts.
3. Align the sensor head using the sensor alignment pointer. Adjust the alignment pointer parallel to the pipe and pointing downstream.
4. Insert the sensor head into the pipe until insertion length, I , is achieved. Do not force the stem into the pipe.
5. Tighten the packing gland nuts to stop leakage around the stem. Do not torque over 20 ft-lbs.
6. Slide the stem clamp back into position. Torque stem clamp bolts to 15 ft-lbs. Replace the stem clamp nuts and torque to 10-15 ft-lbs.

Adjusting Meter Orientation

Depending on installation requirements, you may need to adjust the meter orientation. There are two adjustments available. The first rotates the position of the LCD display/keypad and is available on both in-line and insertion meters. The second is to rotate the enclosure position. This adjustment is only allowed on Series 220 In-Line meters.

Display/Keypad Adjustment (All Meters)

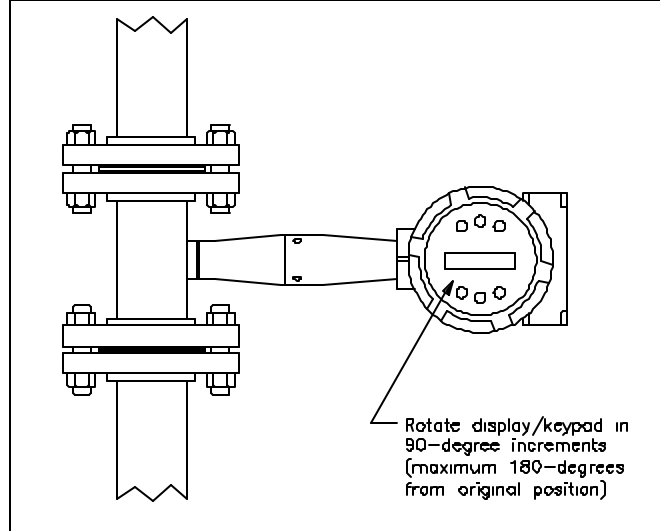

Figure 2-12. Display/Keypad Viewing Adjustment

The electronics boards are electrostatically sensitive. Wear a grounding wrist strap and make sure to observe proper handling precautions required for static-sensitive components. To adjust the display:

1. Disconnect power to the flow meter.
2. Loosen the small set screw which secures the electronics enclosure. Un-screw and remove the cover.
3. Loosen the 4 captive screws.
4. Carefully pull the display/microprocessor board away from the meter standoffs. Make sure not to damage the connected ribbon cable.
5. Rotate the display/microprocessor board to the desired position. Maximum turn, two positions left or two positions right (180-degrees).
6. Align the board with the captive screws. Check that the ribbon cable is folded neatly behind the board with no twists or crimps.
7. Tighten the screws. Replace the cover and set screw. Restore power to the meter.

Enclosure Adjustment (Series 220 Only)

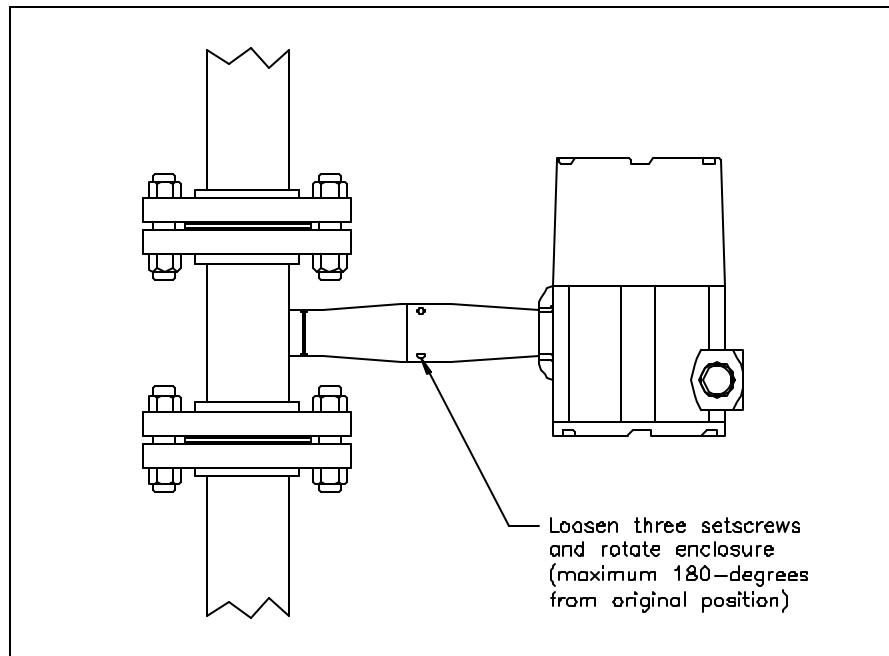

Figure 2-13. Enclosure Viewing Adjustment

To avoid damage to the sensor wires, do not rotate the enclosure beyond 180-degrees from the original position. To adjust the enclosure:

1. Remove power to the flow meter.
2. Loosen the three set screws shown above. Rotate the display to the desired position (maximum 180-degrees).
3. Tighten the three set screws. Restore power to the meter.

**Warning!**

To avoid potential electric shock, follow National Electric Code safety practices or your local code when wiring this unit to a power source and to peripheral devices. Failure to do so could result in injury or death. All wiring procedures must be performed with the power off.

Wiring Connections

The NEMA 4X enclosure contains an integral wiring compartment with one dual strip terminal block (located in the smaller end of the enclosure). Two 3/4-inch female NPT conduit entries are available for separate power and signal wiring. For all hazardous area installations, make sure to use an agency-approved fitting at each conduit entry. If conduit seals are used, they must be installed within 18 inches (457 mm) of the enclosure.

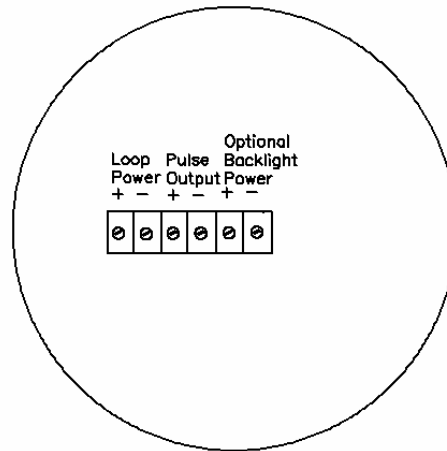

Pulse and Power
Terminals

Input Power Connections

To access the wiring terminal blocks, locate and loosen the small set screw which locks the small enclosure cover in place. Unscrew the cover to expose the terminal block.

DC Power Wiring

Connect 4-20 mA loop power (12 to 36 VDC) to the +Pwr and -Pwr terminals on the terminal block. Torque all connections to 4.43 to 5.31 in-lbs (0.5 to 0.6 Nm). The DC power wire size must be 20 to 10 AWG with the wire stripped 1/2 inch (14 mm). The nominal voltage required to operate the 4-20 mA loop is 12 volts at the meter. The 4-20 mA loop is optically isolated from the flow meter electronics.

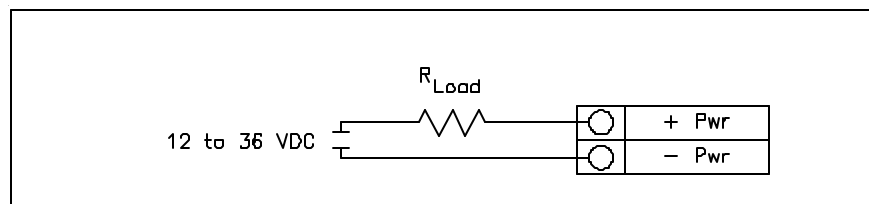

Figure 2-14. DC Power Connections

4-20 mA Output Connections

The Innova-Flo meter has a single 4-20 mA loop. The 4-20 mA loop current is controlled by the meter electronics. The electronics must be wired in series with the sense resistor or current meter. The current control electronics require 12 volts at the input terminals to operate correctly.

The maximum loop resistance (load) for the current loop output is dependent upon the supply voltage and is given in Figure 2-16. The 4-20 mA loop is optically isolated from the flow meter electronics.

R_{load} is the total resistance in the loop, including the wiring resistance ($R_{load} = R_{wire} + R_{sense}$). To calculate R_{max} , the maximum R_{load} for the loop, use the maximum loop current, 20 mA. The voltage drop in the loop due to resistance is 20 mA times R_{load} and this drop is subtracted from the input voltage. Thus:

$$\text{The maximum resistance } R_{load} = R_{max} = 50 * (V_{supply} - 12V).$$

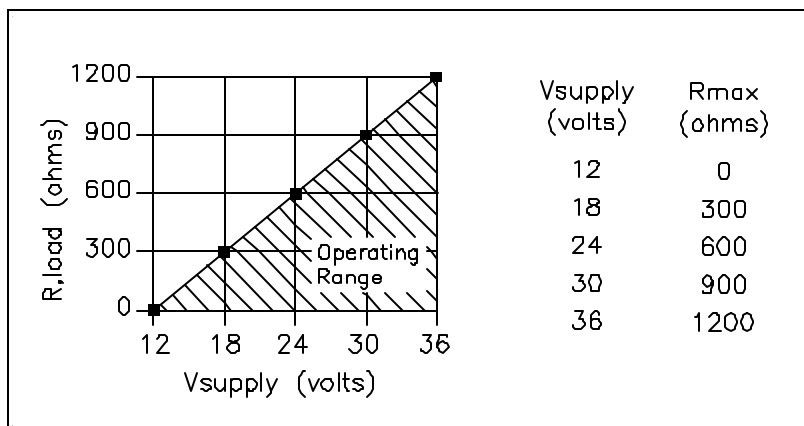

Figure 2-15. Load Resistance Versus Input Voltage

Pulse Output Connections

The pulse output is used for a remote counter. When the preset volume or mass (defined in the totalizer settings, see page 3-6) has passed the meter, the output provides a 50 millisecond square pulse.

The pulse output requires a separate 5 to 36 VDC power supply. The pulse output optical relay is a normally-open single-pole relay. The relay has a nominal 200 volt/160 ohm rating. This means that it has a nominal on-resistance of 160 ohms, and the largest voltage that it can withstand across the output terminals is 200 volts. However, there are current and power specifications that must be observed. The relay can conduct a current up to 40 mA and can dissipate up to 320 mW. The relay output is isolated from the meter electronics and power supply.

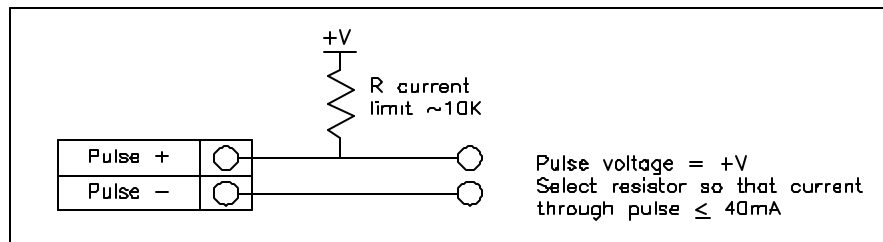
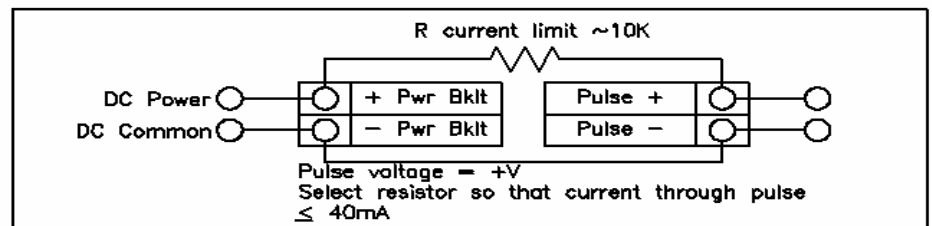
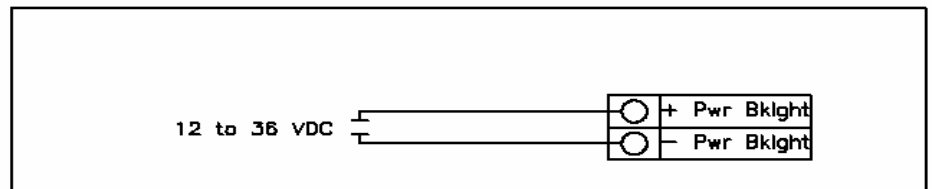

Figure 2-16. Isolated Pulse Output with External Power Supply

Optional Backlight Connection

The Sierra Model 220 has an optional backlight connection provided. It is intended to be powered by a separate 12 to 36 VDC power supply or by the pulse power input. Both options are shown below.



The Sierra Model 220 has an optional backlight connection provided. It is intended to be powered by a separate 12 to 36 VDC power supply or by the pulse

Remote Electronics Wiring

The remote electronics enclosure should be mounted in a convenient, easy to reach location. For hazardous location installations, make sure to observe agency requirements for installation. Allow some slack in the interface cable between the junction box and the remote electronics enclosure. To prevent damage to the wiring connections, do not put stress on the terminations at any time.

The meter is shipped with temporary strain relief glands at each end of the cable. Disconnect the cable from the meter's terminal block inside the junction box—not at the remote electronics enclosure. Remove both glands and install appropriate conduit entry glands and conduit. When installation is complete, re-connect each labeled wire to the corresponding terminal position on the junction box terminal block. Make sure to connect each wire pair's shield. Note: incorrect connection will cause the meter to malfunction.

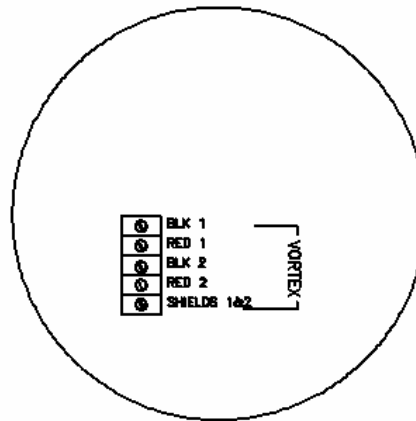

22 FIGURE 2-17

Figure 2-17. Junction Box Sensor Connections

Note: Numeric code in junction box label matches wire labels.

Chapter 3 Operating Instructions

After installing the Innova-Flo Vortex Meter, you are ready to begin operation. The sections in this chapter explain the display/keypad commands, meter start-up and programming. The meter is ready to operate at start up without any special programming. To enter parameters and system settings unique to your operation, see the following pages for instructions on using the setup menus.

Flow Meter Display/Keypad

The flow meter's digital electronics allow you to set, adjust and monitor system parameters and performance. A full range of commands are available through the display/keypad. The LCD display gives 2 x 16 characters for flow monitoring and programming. The six push buttons are operable either directly on the display panel or with a hand-held magnet through the explosion-proof enclosure.

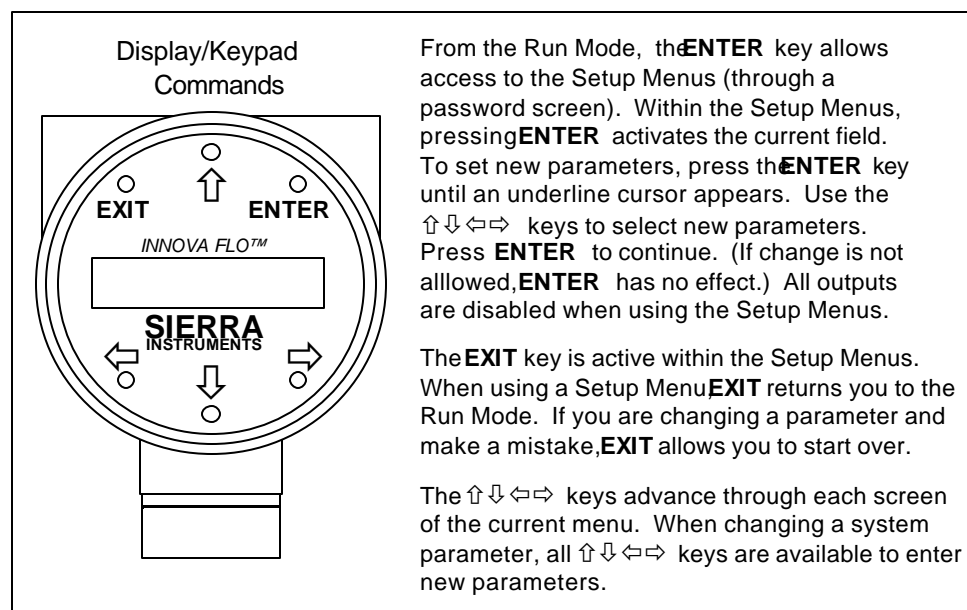

Figure 3-1. Flow Meter Display/Keypad

Start-Up



Note

Starting the flow meter or pressing **EXIT** will always display the Run Mode screens.

To begin flow meter operation:

1. Verify the flow meter is installed and wired as described in Chapter 2.
2. Apply power to the meter. At start up, the unit runs a series of self-tests that check the program configuration and all flow sensing components. After completing the self-test sequence, the Run Mode screens appear.
3. The Run Mode displays flow information as determined by settings entered in the Display Menu (page 3-5). Press the $\uparrow\downarrow$ arrow keys to view the Run Mode screens.

Press the **ENTER** key from any Run Mode screen to access the Setup Menus. Use the Setup Menus to configure the meter's multi-parameter features to fit your application.

Run Mode Screens

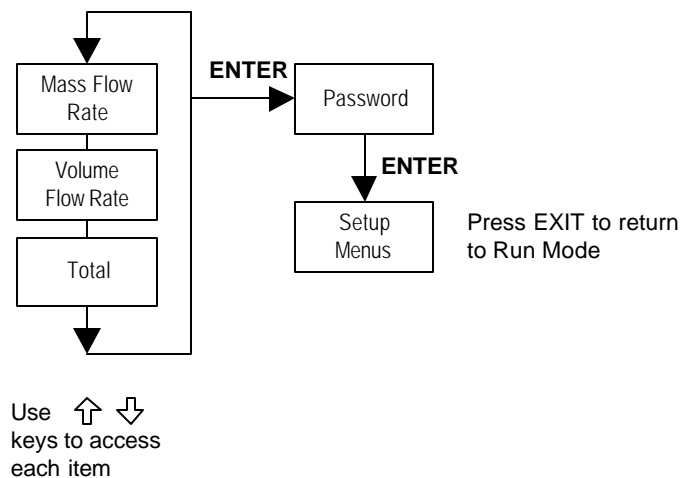

To operate the six push buttons through the display enclosure, use the hand held magnet as shown at right.

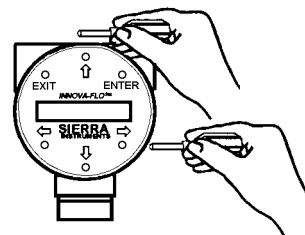

Using the Setup Menus

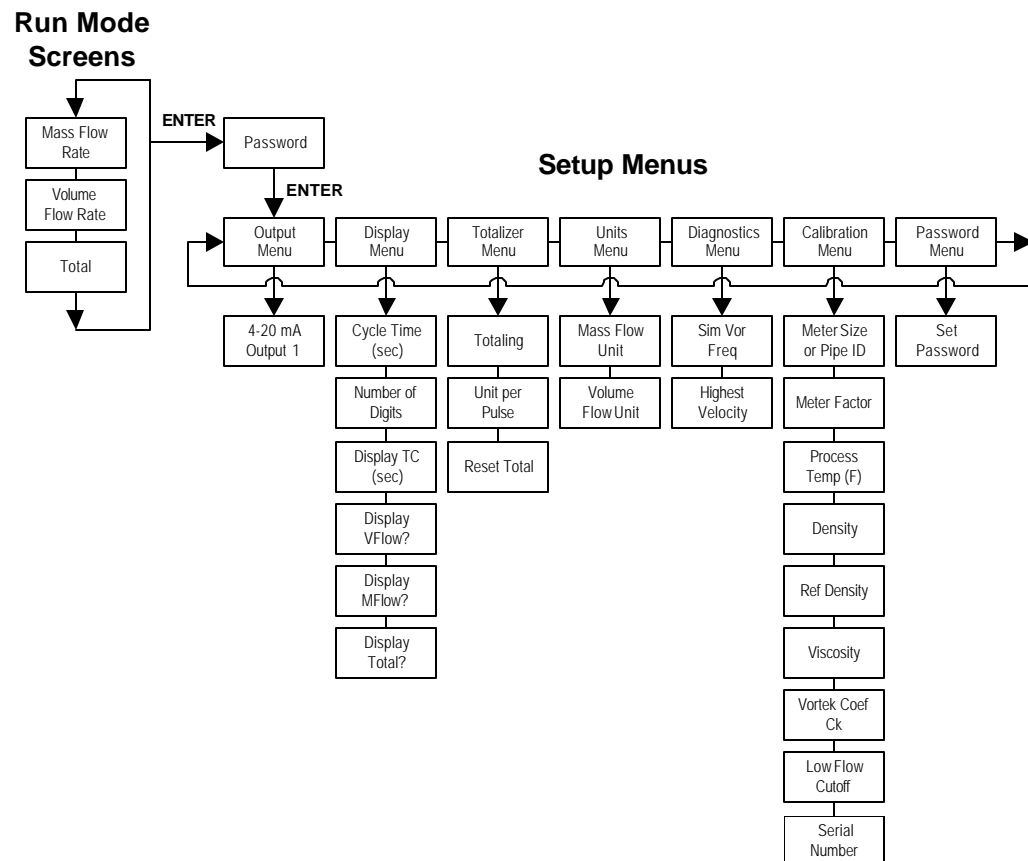

Programming the Flow Meter

1. Enter the Setup Menu by pressing the ENTER key until prompted for a password. (All outputs are disabled while using the Setup Menus.)
2. Use the \uparrow \downarrow \leftarrow \rightarrow keys to select the password characters (1234 is the factory-set password). When the password is correctly displayed, press ENTER to continue.
3. Use the Setup Menus described on the following pages to customize the multi-parameter features of your Innova-Flo Vortex Meter. (The entire lower display line is available for entering parameters.)
4. To activate a parameter, press ENTER. Use the \uparrow \downarrow \leftarrow \rightarrow keys to make selections. Press ENTER to continue. Press EXIT to save or discard changes and return to Run Mode.

Output Menu

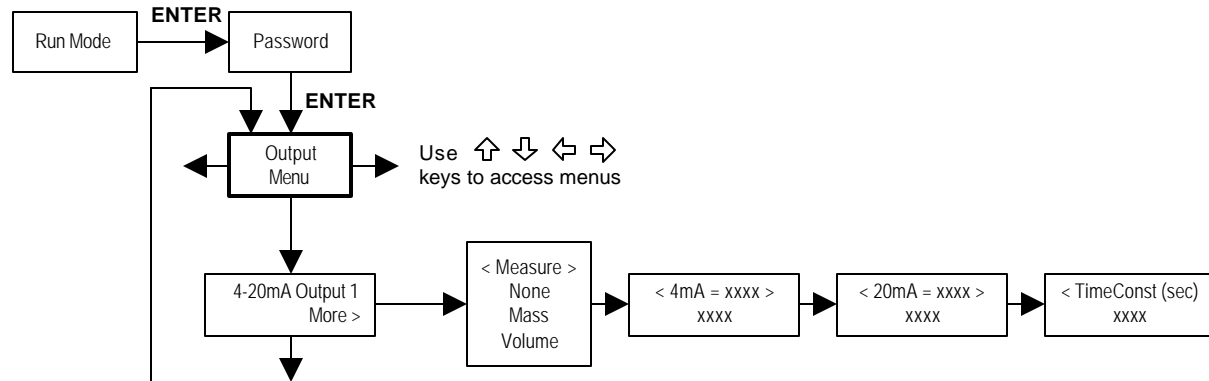

Example for Setting an Output

The following shows how to set Output 1 to measure volumetric flow with 4 mA = 0 gal/min and 20 mA = 100 gal/min with a time constant of 5 seconds. (All outputs are disabled while using the Setup Menus.)

First, set the desired units of measurement:

1. Use $\leftarrow \rightarrow$ keys to move to the Units Menu (see page 3-8).
2. Press \downarrow key until Volume Flow Unit appears. Press ENTER.
3. Press \downarrow key until gal appears in the numerator. Press \Rightarrow key to move the underline cursor to the denominator. Press the \downarrow key until min appears in the denominator. Press ENTER to select.
4. Press \uparrow key until Units Menu appears.

Second, set the analog output:

1. Use $\leftarrow \rightarrow$ keys to move to the Output Menu.
2. Press the \downarrow key until 4-20mA Output 1 appears.
3. Press \Rightarrow key to access Measure selections. Press ENTER and press the \downarrow key to select Volume. Press ENTER.
4. Press \Rightarrow key to set the 4 mA point in the units you have selected for volume of gal/min. Press ENTER and use $\uparrow \downarrow \leftarrow \rightarrow$ keys to set 0 or 0.0. Press ENTER.
5. Press \Rightarrow key to set the 20 mA point. Press ENTER and use $\uparrow \downarrow \leftarrow \rightarrow$ keys to set 100 or 100.0. Press ENTER.
6. Press \Rightarrow key to select the Time Constant. Press ENTER and use $\uparrow \downarrow \leftarrow \rightarrow$ keys to select 5. Press ENTER.
7. Press the EXIT key and answer YES to permanently save your changes.

Display Menu

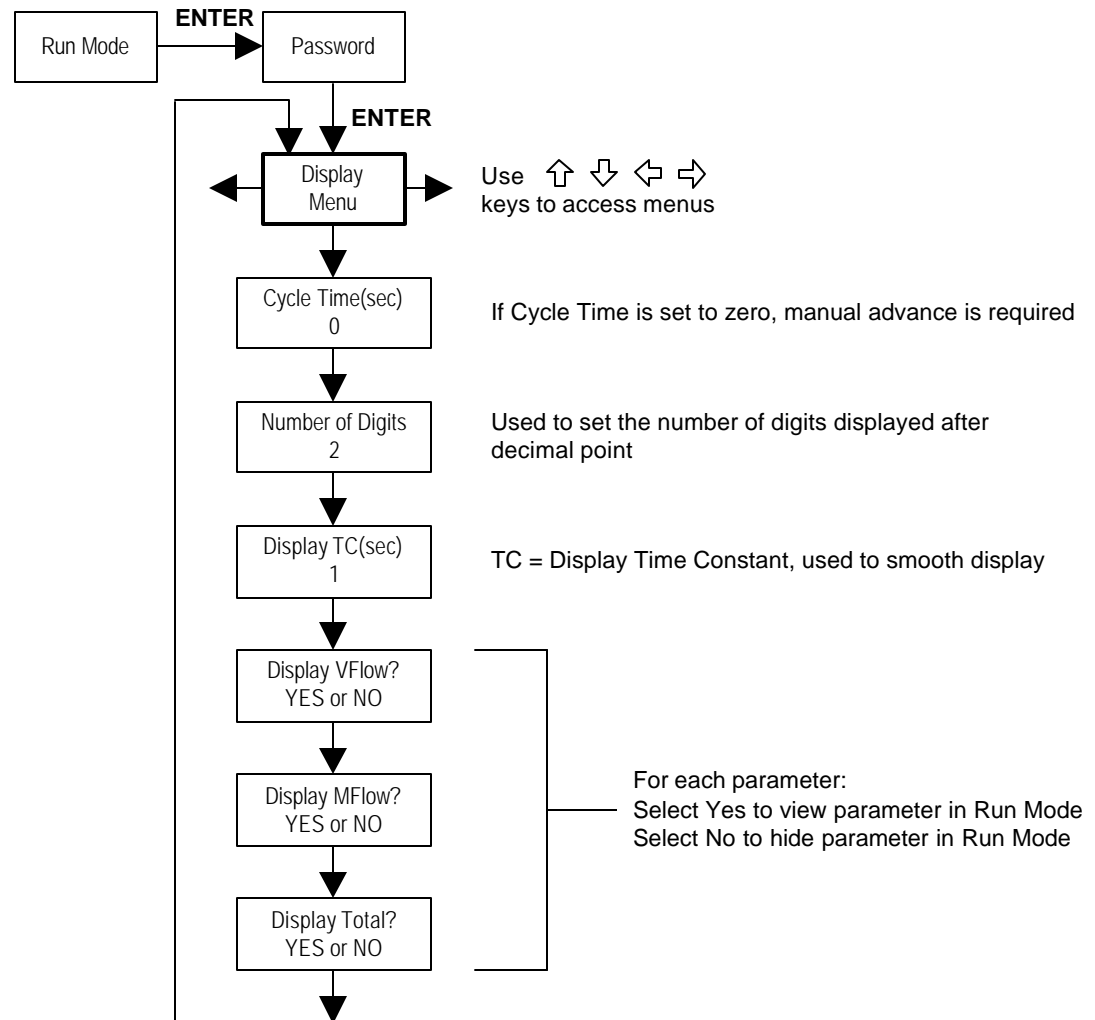

Use the Display Menu to set the cycle time for automatic screen sequencing used in the Run Mode, change the precision of displayed values, smooth the values or enable or disable each item displayed in the Run Mode screens.

Example for Changing a Run Mode Display Item

The following shows how to remove the mass flow screen from the Run Mode screens. Note: all outputs are disabled while using the Setup Menus.

1. Use ←→ keys to move to the Display Menu.
2. Press ↓ key until Display MFlow? appears.
3. Press ENTER to select.
4. Press ↓ key until N appears. Press ENTER to select.
5. Press EXIT and then ENTER to save changes and return to the Run Mode.

Totalizer Menu

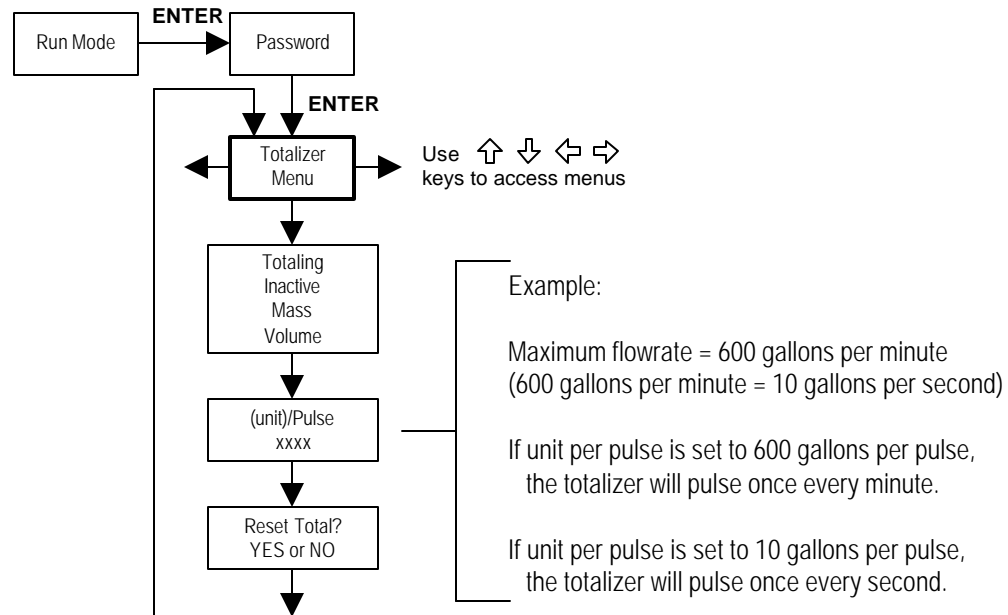

Use the Totalizer Menu to configure and monitor the totalizer. The totalizer output is a 50 millisecond (.05 second) positive pulse (relay closed for 50 milliseconds). The totalizer cannot operate faster than one pulse every 100 millisecond (.1 second). A good rule to follow is to set the unit per pulse value equal to the maximum flow in the same units per second. This will limit the pulse to no faster than one pulse every second.

Example for Setting the Totalizer

The following shows how to set the totalizer to track volumetric total gallons. (All outputs are disabled while using the Setup Menus.)

First, set the desired units of measurement:

1. Use keys to move to the Units Menu (see to page 3-8).
2. Press key until Volume Flow Unit appears. Press ENTER.
3. Press key until gal appears in the numerator. Press key to move the underline cursor to the denominator. Press the key until min appears in the denominator. Press ENTER to select.
4. Press key until Units Menu appears.

Second, set the pulse output:

1. Use keys to move to the Totalizer Menu.
2. Press the key until Totaling appears.
3. Press ENTER and press the key to select Volume. Press ENTER.
4. Press key to set the gallons per pulse. Press ENTER and use keys to set the pulse value equal to the maximum flow in the same units per second. This will limit the frequency to 1 Hz. Press ENTER.
5. To reset the totalizer, press key until Reset Total? appears. Press ENTER and the key to reset the totalizer if desired. Press ENTER.
6. Press the EXIT key and answer YES to permanently save your changes.

Diagnostics Menu

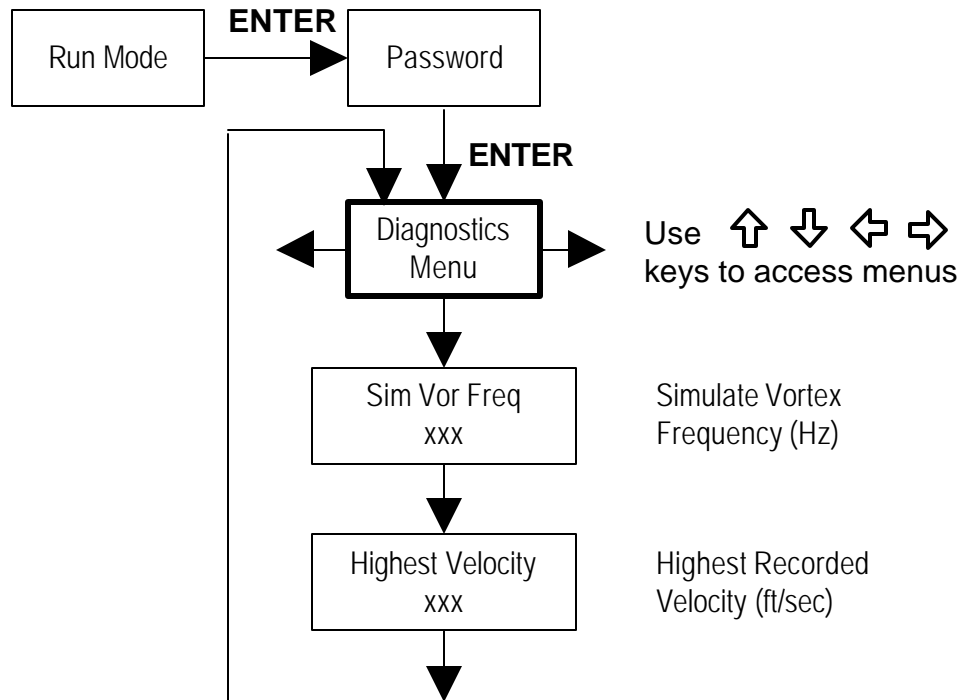

Use the Diagnostics Menu to simulate flow and review the highest recorded velocity in ft/sec.

The simulated vortex frequency is used for testing the meter to verify that the programming is correct. Enter any value for the sensor input in Hz. The meter will calculate a flow rate based on the corresponding value and update the analog output and totalizer pulse output. Note: when your diagnostic work is complete, make sure to return the simulated frequency to zero to allow the electronics to use the actual value.

Calibration Menu

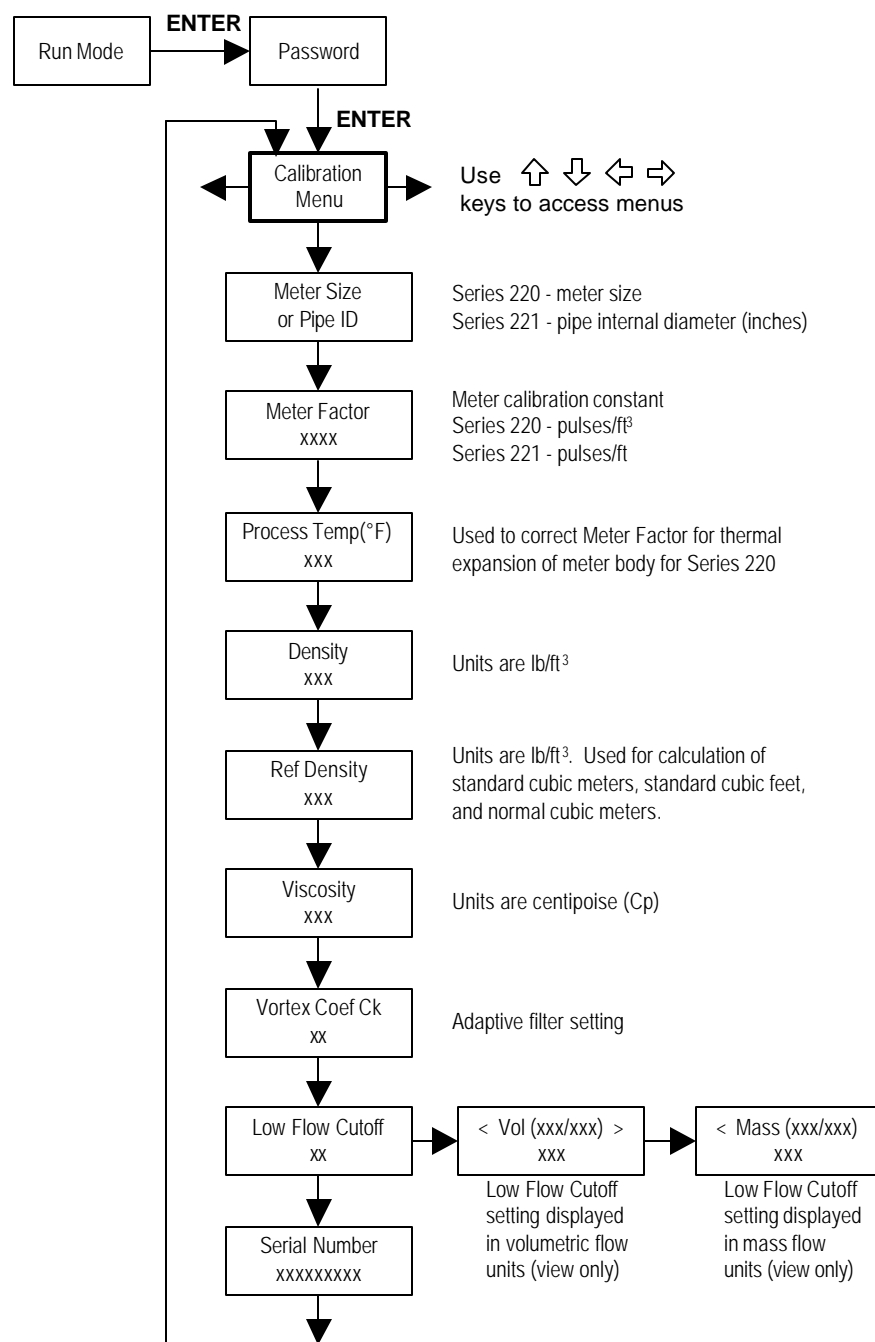

The Calibration Menu contains the calibration coefficients for the flow meter. These values should be changed only by properly trained personnel. The Vortex Coef Ck and Low Flow Cutoff are set at the factory. Consult the factory for help with these settings if the meter is showing erratic flow rate. The units of measurement used in the Calibration Menu are preset and are as follows: Density = lbm/ft³, Reference Density = lbm/ft³, Viscosity = centipoise.

Password Menu

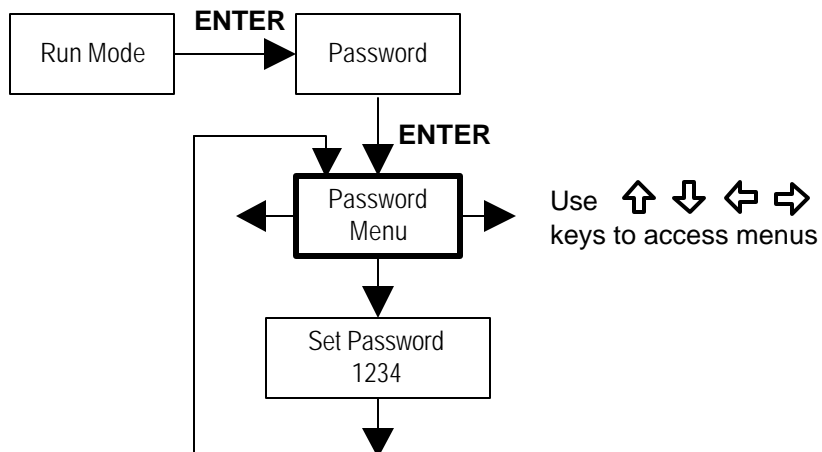

Use the Password Menu to set or change the system password.
The factory-set password is 1234.

Chapter 4 HART Communications

Wiring

The diagram below details the proper connections required for HART communications:



Warning!

Place controls in manual mode when making configuration changes to the vortex meter.

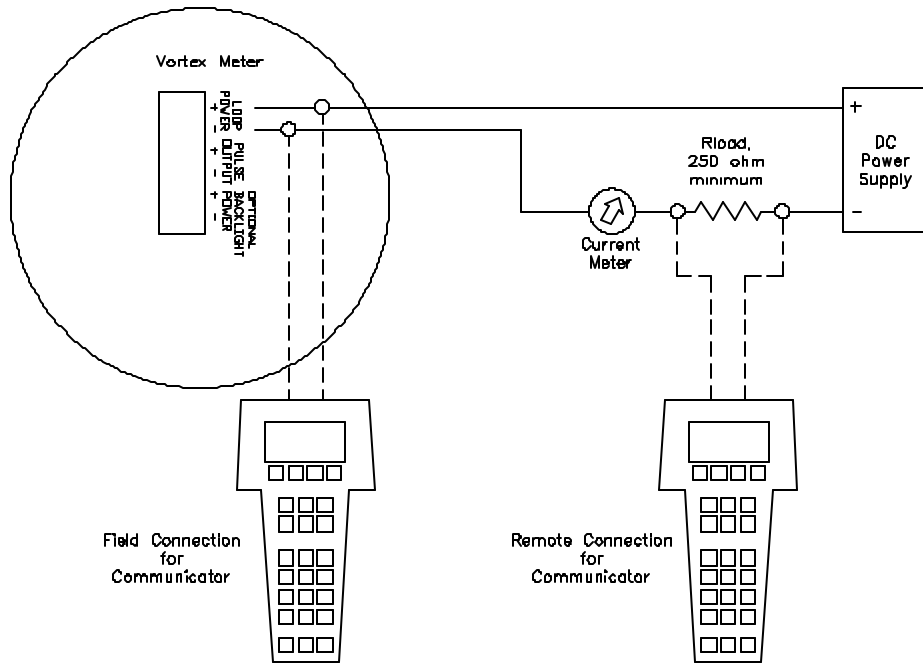

HART Menu

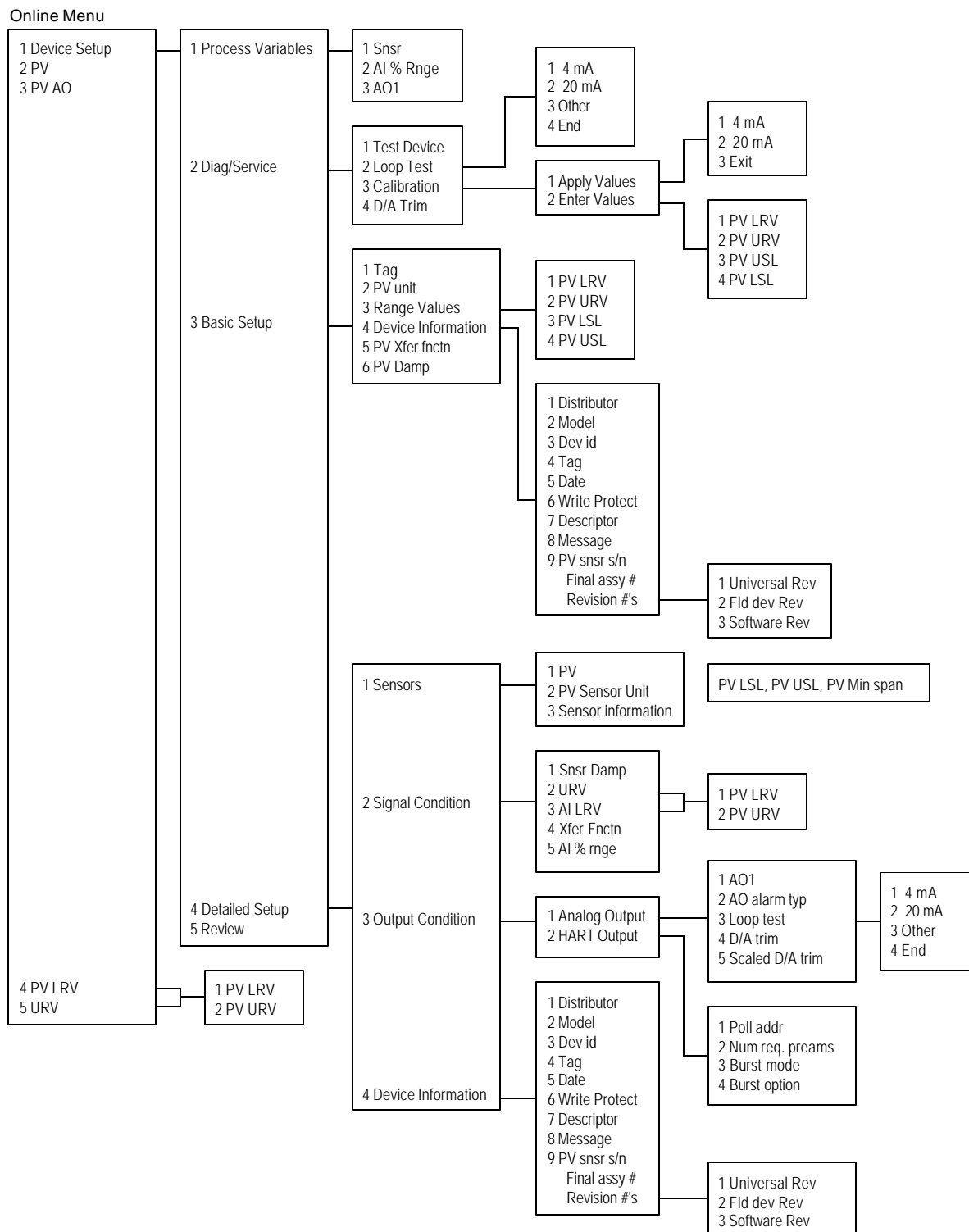

Use password 16363.

Fast Key Sequence

Use password 16363.

Sequence	Description	Access	Notes
1,1,1	Snsr	View	Primary variable value
1,1,2	AI % Rnge	View	Analog output % range
1,1,3	AO1	View	Analog output, mA
1,2,1	Test Device	N/A	Not used
1,2,2,1	4 mA	View	Loop test, fix analog output at 4 mA
1,2,2,2	20 mA	View	Loop test, fix analog output at 20 mA
1,2,2,3	Other	Edit	Loop test, fix analog output at mA value entered
1,2,2,4	End		Exit loop test
1,2,3,1,1	4 mA	N/A	Not used, apply values
1,2,3,1,2	20 mA	N/A	Not used, apply values
1,2,3,1,3	Exit		Exit apply values
1,2,3,2,1	PV LRV	Edit	Primary variable lower range value
1,2,3,2,2	PV URV	Edit	Primary variable upper range value
1,2,3,2,3	PV USL	View	Primary variable upper sensor limit
1,2,3,2,4	PV LSL	View	Primary variable lower sensor limit
1,2,4	D/A Trim	Edit	Calibrate electronics 4mA and 20mA values
1,3,1	Tag	Edit	Tag
1,3,2	PV unit	Edit	Primary variable units
1,3,3,1	PV LRV	Edit	Primary variable lower range value
1,3,3,2	PV URV	Edit	Primary variable upper range value
1,3,3,3	PV LSL	View	Primary variable upper sensor limit
1,3,3,4	PV USL	View	Primary variable lower sensor limit
1,3,4,1	Distributor	N/A	Not used
1,3,4,2	Model	N/A	Not used
1,3,4,3	Dev id	View	Device identification
1,3,4,4	Tag	Edit	Tag
1,3,4,5	Date	Edit	Date
1,3,4,6	Write Protect	View	Write protect
1,3,4,7	Descriptor	Edit	Vortex flowmeter
1,3,4,8	Message	Edit	32 character alphanumeric message
1,3,4,9	PV snsr s/n	View	Primary variable sensor serial number
1,3,4,menu	Final assy #	Edit	Final assembly number
1,3,4,menu,1	Universal Rev	View	Universal revision
1,3,4,menu,2	Fld dev Rev	View	Field device revision
1,3,4,menu,3	Software Rev	View	Software revision
1,3,5	PV Xfer fnctn	View	Linear
1,3,6	PV Damp	Edit	Primary variable damping (time constant) in seconds
1,4,1,1	PV	View	Primary variable value
1,4,1,2	PV Sensor Unit	Edit	Primary variable units
1,4,1,3	Sensor Information	View	PV LSL, PV USL, PV Min span
1,4,2,1	Snsr Damp	Edit	Primary variable damping (time constant) in seconds
1,4,2,2,1	PV LRV	Edit	Primary variable low range value
1,4,2,2,2	PV URV	Edit	Primary variable upper range value
1,4,2,3,1	PV LRV	Edit	Primary variable low range value
1,4,2,3,2	PV URV	Edit	Primary variable upper range value
1,4,2,4	Xfer Fnctn	View	Linear
1,4,2,5	AI % rng	View	Analog output % range
1,4,3,1,1	AO1	View	Analog output, mA

1,4,3,1,2	AO alarm typ	N/A	Not used
-----------	--------------	-----	----------

Continued on next page

Sequence	Description	Access	Notes
1,4,3,1,3,1	4 mA	View	Loop test, fix analog output at 4 mA
1,4,3,1,3,2	20 mA	View	Loop test, fix analog output at 20 mA
1,4,3,1,3,3	Other	Edit	Loop test, fix analog output at mA value entered
1,4,3,1,3,4	End		Exit loop test
1,4,3,1,4	D/A trim	Edit	Calibrate electronics 4mA and 20mA values
1,4,3,1,5	Scaled D/A trim	N/A	Not used
1,4,3,2,1	Poll addr	Edit	Poll address
1,4,3,2,2	Num req. preams	View	Number of required preambles
1,4,3,2,3	Burst mode	N/A	Not used
1,4,3,2,4	Burst option	N/A	Not used
1,4,4,1	Distributor	N/A	Not used
1,4,4,2	Model	N/A	Not used
1,4,4,3	Dev id	View	Device identification
1,4,4,4	Tag	Edit	Tag
1,4,4,5	Date	Edit	Date
1,4,4,6	Write Protect	View	Write protect
1,4,4,7	Descriptor	Edit	Vortex flowmeter
1,4,4,8	Message	Edit	32 character alphanumeric message
1,4,4,9	PV snsr s/n	View	Primary variable sensor serial number
1,4,4,menu	Final assy #	Edit	Final assembly number
1,4,4,menu,1	Universal Rev	View	Universal revision
1,4,4,menu,2	Fld dev Rev	View	Field device revision
1,4,4,menu,3	Software Rev	View	Software revision
1,5	Review	N/A	Not used
2	PV	View	Primary variable value
3	PV AO	View	Analog output, mA
4,1	PV LRV	Edit	Primary variable lower range value
4,2	PV URV	Edit	Primary variable upper range value
5,1	PV LRV	Edit	Primary variable lower range value
5,2	PV URV	Edit	Primary variable upper range value

Chapter 5 Troubleshooting and Repair

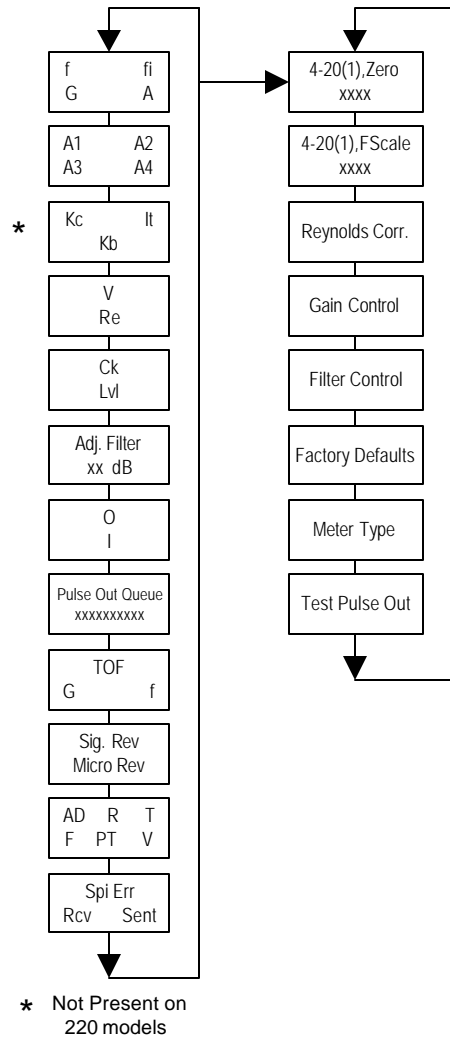

Hidden Diagnostics Menus



Warning!

Before attempting any flow meter repair, verify that the line is not pressurized. Always remove main power before disassembling any part

The menus shown above can be accessed using the password 16363, then moving to the display that reads “Diagnostics Menu” and pressing ENTER (rather than one of the arrow keys).

Use the right arrow key to move to the second column. Press EXIT to move from the second column back to the first, press EXIT while in the first column to return to the setup menus.

Caution: password 16363 will allow full access to the configuration and should be used carefully to avoid changes that can adversely alter the function of the meter.

Each of the menus above will first be defined followed by specific troubleshooting steps.

Column One Hidden Diagnostics Values

- **f** = vortex shedding frequency (Hz). If an asterisk (*) is displayed after the f value, a valid vortex signal is being registered for the flow.
- **fi** = adaptive filter – should be approximately 25% higher than the vortex shedding frequency, this is a low-pass filter. If the meter is using the Filter Control (see below) in the manual mode, **fi** will be displayed as **fm**.
- **G** = gain (applied to vortex signal amplitude). Gain defaults to 1.0 and can be changed using the Gain Control (see below).
- **A** = Amplitude of the vortex signal in Volts rms.
- **A1, A2, A3, A4** = A/D counts representing the vortex signal amplitude. Each stage (A1-A4) cannot exceed 512. Beginning with stage A1, the A/D counts increase as the flow rate increases. When stage A1 reaches 512, it will shift to stage A2. This will continue as the flow rate increases until all 4 stages read 512 at high flow rates. Higher flow rates (stronger signal strength) will result in more stages displaying 512.
- **Kc, It, Kb** = profile equation (factory use only). Series 221 only.
- **V** = calculated average pipe velocity (ft/sec).
- **Re** = calculated Reynolds number.
- **Ck** = calculated Ck at current operating conditions. Ck is a variable in the equation that relates signal strength, density, and velocity for a given application. It is used for noise rejection purposes. Ck directly controls the fi value (see above). If the Ck is set too low (in the calibration menu), then the fi value will be too low and the vortex signal will be rejected resulting in zero flow rate being displayed. The calculated Ck value in this menu can be compared to the actual Ck setting in the calibration menu to help determine if the Ck setting is correct.
- **Lvl** = threshold level. If the Low Flow Cutoff in the calibration menu is set above this value, the meter will read zero flow. The Lvl level can be checked at no flow. At no flow, the Lvl must be below the Low Flow Cutoff setting or the meter will have an output at no flow.
- **Adj. Filter** = adjustable filter. Displays the filtering in decibels. Normally reads zero. If this value is consistently -5 or -10 , for example, the Ck or density setting may be wrong.

- **O, I** = factory use only.
- **Pulse Out Queue** = Pulse output queue. This value will accumulate if the totalizer is accumulating faster than the pulse output hardware can function. The queue will allow the pulses to “catch up” later if the flow rate decreases. A better practice is to slow down the totalizer pulse by increasing the value in the (unit)/pulse setting in the totalizer menu.
- **TOF, G, f** = factory use only.
- **Sig. Rev** = Signal board hardware and firmware revision.
- **Micro Rev** = Microprocessor board hardware and firmware revision.
- **AD, R, T, F, PT, V** = factory use only.
- **SPI Err, Rcv, Sent** = factory use only.

Column Two Hidden Diagnostics Values

- **4-20(1), Zero** = Analog counts to calibrate zero on analog output.
- **4-20(1), FScale** = Analog counts to calibrate full scale on analog output.
- **Vor Freq Direct?** = Frequency output setting, used by factory during calibration. Set to NO if totalizer is used.
- **Reynolds Corr.** = Reynolds number correction for the flow profile. Set to Enable for series 221 insertion and set to Disable for series 220 inline.
- **Gain Control** = Manual gain control (factory use only). Leave set at 1.0.
- **Filter control** = Manual filter control. This value can be changed to any number to force the fi value (which will be displayed as fm) to a constant. A value of zero activates the automatic filter control which sets fi at a level that floats above the f value.
- **Factory Defaults** = Reset to factory defaults. If you change this to YES and press ENTER, all factory configuration is lost and you must reconfigure the entire program. Consult the factory before performing this process, it is required only in very rare cases.
- **Meter Type** = Insertion (model 221) or Inline (model 220) meter.
- **Test Pulse Out** = Force totalizer pulse. Set to YES and press ENTER to send one pulse. Very useful to test totalizer counting equipment.

Analog Output Calibration

To check the 4–20 mA circuit, connect a DVM in series with the output loop. Select zero or full scale (from the second column of the hidden diagnostics) and then actuate the enter key twice. This action will cause the meter to output its 4 mA or 20 mA condition. If the DVM indicates a current greater than ± 0.006 mA from 4 or 20, adjust the setting up or down until the output is calibrated. Note: these settings are not for adjusting the output zero and span to match a flow range, that function is located in the Output Menu.

Troubleshooting the Flow Meter

Symptom: Output at no Flow

1. The low flow cutoff is set too low. At no flow, go to the first column of the hidden diagnostics menu and record Lvl value. The low flow cutoff must be set above this value.

Example: at no flow, Lvl = 25. Set the low flow cutoff in the Calibration Menu to approximately 28 and the meter will no longer read a flow rate at no flow.

Symptom: Erratic Output

1. The flow rate may be too low, just at the cutoff of the meter range, and the flow cycles above and below the cutoff making an erratic output. The meter range is stamped on the label on the outside of the electronics enclosure cover (based on application conditions when the meter was ordered). Consult the factory if necessary to confirm the meter range based on current operating conditions. It may be possible to lower the low flow cutoff to increase the meter range. See the example above for output at no flow, only this time the low flow cutoff is set too high. You can lower this value to increase the meter range as long as you do not create the output at no flow condition previously described.
2. Mechanical installation may be incorrect. Verify the straight run is adequate as described in Chapter 2. For in-line meters, make sure the meter is not installed backwards and there are no gaskets protruding into the flow stream. For insertion meters, verify the insertion depth and flow direction.
3. The meter may be reacting to actual changes in the flow stream. The output can be smoothed using a time constant. The displayed values can be smoothed using the time constant in the Display Menu. The analog outputs can be smoothed using the time constant in the Output Menu. A time constant of 1 will result in the change in value reaching 63% of its final value in one second. A time constant of 4 is

22%, 10 is 9.5% and 50 is 1.9% of the final value in one second. The time constant equation is shown below (TC = Time Constant).

$$\begin{array}{l} \text{\% change to final value} \\ \text{in one second} \end{array} = 100 (1 - e^{(-1/TC)})$$

4. The vortex coefficient Ck may be incorrectly set. The Ck is a value in the equation used to determine if a frequency represents a valid vortex signal given the fluid density and signal amplitude. In practice, the Ck value controls the adaptive filter, fi, setting. During flow, view the f and fi values in the first column of the hidden diagnostics. The fi value should be approximately 25 % higher than the f value. If you raise the Ck setting in the Calibration Menu, then the fi value will increase. The fi is a low pass filter, so by increasing it or lowering it, you can alter the range of frequencies that the meter will accept. If the vortex signal is strong, the fi value will increase to a large number – this is correct.

Symptom: No Output

1. For remote mounted electronics, carefully check all the wiring connections in the remote mount junction box. There are 6 connections that must be correct, verify each color (black and red), shield, and wire number.
2. Check the density value in the Calibration Menu to see if it is correct for the current operating conditions.
3. Using ESD precautions and hazardous area precautions, remove the electronics enclosure window cover. Disconnect the vortex sensor from the Signal board. Measure the resistance from each Sensor pin to the meter ground - each should be open, (see drawing below). Measure the resistance from the Ground pin to the meter ground – this should be grounded to the meter. With the sensor still disconnected, go the first column of the hidden diagnostics and display the vortex shedding frequency, f. Hold a finger on the four exposed pins on the Signal board. The meter should read electrical noise, 60 Hz for example. If all readings are correct, re-install vortex sensor wires.
4. Verify all meter configuration and troubleshooting steps previously described. There are many possible causes of this problem, consult factory if necessary.

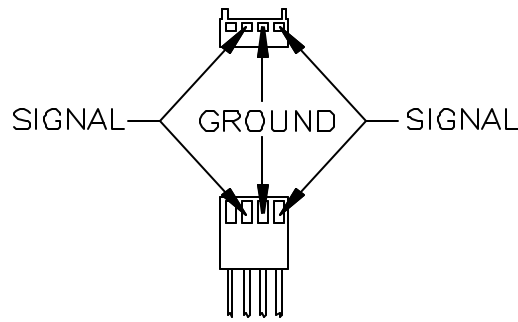

Electronics Assembly Replacement (All Meters)

The electronics boards are electrostatically sensitive. Wear a grounding wrist strap and make sure to observe proper handling precautions required for static-sensitive components.



Warning!

Before attempting any flow meter repair, verify that the line is not pressurized.

Always remove main power before disassembling any part

1. Turn off power to the unit.
2. Locate and loosen the small set screw which locks the larger enclosure cover in place. Unscrew the cover to expose the electronics stack.
3. Locate the sensor connector that comes up from the neck of the flow meter and attaches to the circuit board. Use small pliers to pull the connector off of the circuit board.
4. Locate and loosen the small set screw which locks the smaller enclosure cover in place. Unscrew the cover to expose the field wiring strip. Tag and remove the field wires.
5. Remove the screws that hold the black wiring label in place, remove the label.
6. Locate the 4 Phillips head screws which are spaced at 90-degrees around the terminal board. These screws hold the electronics stack in the enclosure. Loosen these screws (Note: that these are captive screws, they will stay inside the enclosure).
7. Carefully remove the electronics stack from the opposite side of the enclosure. If the electronics stack will not come out, gently tap the terminal strip with the screw driver handle. This will loosen the rubber sealing gasket on the other side of the enclosure wall. Be careful that the stack does not hang up on the loose sensor harnesses.

8. Repeat steps 1 through 6 in reverse order to install the new electronics stack.

Returning Equipment to the Factory

Before returning any Innova-Flo meter to the factory, you must request a Return Material Authorization (RMA) number. To obtain an RMA number and the correct shipping address, contact Customer Service at:

(800) 866-0200 or (831) 373-0200 in the USA,
or +31(0)20-6145810 in Europe.

When contacting Customer Service, be sure to have the meter serial number and model code.

When requesting further troubleshooting guidance, record the following values first:

f, fi, G, and A at no flow and during flow if possible.
Pressure, temperature, and flow rate

Appendix A Product Specifications

Accuracy

Process	220 Series In-Line Meters		221 Series Insertion Meters ⁽¹⁾	
Variables	Liquids	Gas & Steam	Liquids	Gas & Steam
Volumetric Flow Rate	±0.7% of rate over a 30:1 range ⁽²⁾	±1% of rate over a 30:1 range ⁽²⁾	±1.2% of rate over a 30:1 range ⁽²⁾	±1.5% of rate over a 30:1 range ⁽²⁾

Notes: (1) Accuracies stated are for the total volumetric flow through the pipe.

(2) Nominal rangeability is stated. Precise rangeability depends on fluid

and pipe size.

Repeatability

0.1% of rate.

Response Time

Adjustable from 1 to 100 seconds.

Material Compatibility

Series 220 In-Line Flow Meter:

Any gas, liquid or steam compatible with 316L stainless steel, C276 hastelloy or A105 carbon steel. Not recommended for multi-phase fluids.

Series 221 Insertion Flow Meter:

Any gas, liquid or steam compatible with 316L stainless steel. Not recommended for multi-phase fluids.

Flow rates

Typical volumetric flow ranges are given in the following tables. Precise flow range depends on the fluid and pipe size. 221 insertion meters are applicable to pipe sizes from 2 inch and above. Consult factory for sizing program.

Air Minimum and Maximum Flow Rates (scfm) (1)									
Pressure	½-inch	¾-inch	1-inch	1.5-inch	2-inch	3-inch	4-inch	6-inch	8-inch
0 psig	1.8	3.3	5	13	22	50	88	198	347
	17.5	41.4	90	221	369	826	1438	3258	5708
100 psig	5	9.2	15	37	62	138	240	543	952
	137	324	701	1728	2879	6447	11222	25421	44536
200 psig	6.8	12.6	20	50	83	185	322	730	1279
	257	608	1313	3234	5389	12067	21006	47585	67122
300 psig	8.3	15.3	24	59	98	220	382	866	1518
	378	893	1924	4740	7900	17687	30789	48821	64552
400 psig	9.5	17.5	27	66	110	247	430	975	1708
	500	1178	2535	6246	10410	23308	31141	46884	61990
500 psig	10.6	19.5	29	72	120	270	469	1063	1862
	620	1464	3147	7752	12920	22592	29834	44915	59387

Note: (1) Standard conditions are 70° F and 1 atmosphere.

Steam Minimum and Maximum Flow Rates (lb/hr)									
Pressure	½-inch	¾-inch	1-inch	1.5-inch	2-inch	3-inch	4-inch	6-inch	8-inch
5 psig	6.5	12	20	49	82	183	319	722	1265
	51.7	122	265	652	1087	2434	4237	9598	16815
100 psig	14.8	27.4	46	112	187	419	729	1651	2893
	270	639	1385	3413	5688	12735	22168	50219	87980
200 psig	20	37	61	151	252	565	984	2229	3905
	493	1164	2524	6217	10362	23200	40385	91485	160275
300 psig	24	44.5	74	182	304	681	1185	2685	4707
	716	1689	3662	9021	15035	33664	58601	132750	232570

	2-inch 300 lb flange	316L SS	ANSI 300 lb	PGR
	2-inch 600 lb flange	316L SS	ANSI 600 lb	PHR

Process Fluid and Ambient Temperature	<p><u>Process Fluid:</u> Standard temperature sensor: -40° to 400° F (-40° to 205° C). Medium temperature sensor: 250° to 500° F (120° to 260° C). High temperature sensor: 250° to 750° F (120° to 400° C).</p> <p><u>Ambient:</u> Operating: -5° to 140° F (-20° to 60° C). Storage: -40° to 150° F (-40° to 65° C). 0-98% relative humidity, non-condensing conditions.</p>
Power Requirements	Loop powered, 12 to 36 VDC.
Output Signals	<p>Analog: field rangeable linear, 4-20 mA output signal, 1000 ohms maximum loop resistance, selected by user for volumetric flow rate or mass flow rate.</p> <p>Pulse: field rangeable volume/pulse output for totalization is a 50-millisecond duration pulse operating a solid-state relay capable of switching 40 VDC, 40 mA maximum.</p>
Display	<p>Alphanumeric 2 x 16 LCD digital display. Six push buttons (up, down, right, left, enter, exit) operable either directly on the display panel or with a hand-held magnet through the display glass of the explosion-proof enclosure. Viewing at 90° mounting intervals.</p>
Totalizer	Based on user-determined flow units, six significant figures in scientific notation. Total stored in non-volatile memory.
Wetted Materials	<p>Series 220 In-Line Flow Meter: 316L stainless steel standard. C276 hastelloy or A105 carbon steel optional.</p> <p>Series 221 Insertion Flow Meter: 316L stainless steel standard. Teflon[®] packing gland below 500° F (205° C). Graphite packing gland above 500° F (205° C).</p>
Enclosure	NEMA 4X cast enclosure.
Electrical Ports	Two 3/4-inch female NPT ports.
Mounting Connections	<p>Series 220: Wafer or 150, 300, 600 lb ANSI flange. Series 221 Permanent installation: 2-inch MNPT; 150, 300, 600 lb ANSI flange with compression fitting probe seal. Series 221 Hot Tap⁽¹⁾ Installation: 2-inch MNPT; 150, 300, 600 lb ANSI flange and optional retractor with packing gland probe seal. Note: (1) Removable under line pressure.</p>
Mounting Position ⁽¹⁾	<p>Series 220 In-Line Flow Meter: No effect. Series 221 Insertion Flow Meter: Meter must be perpendicular within ± 5° of the pipe centerline. Note: (1) For liquid applications, pipeline must remain full at all times.</p>
Certifications	<p>Construction Inspection (ANSI/ASME B31.3). Materials (NACE MR-01-75[90]). CE and FM approved.</p>

CSA, CENELEC approval pending.

FM approvals:

Class I, Division 1, Groups B, C, & D, T6 at Tamb = 60°C

Class II/III, Division 1, Groups E, F, & G

IP66, NEMA 4X

Appendix B Glossary

A B C D

A	Cross sectional area.
acfm	Actual cubic feet per minute (volumetric flow rate).
ASME	American Society of Mechanical Engineers.
Bluff Body	A non-streamlined body placed into a flow stream to create vortices. Also called a Shedder Bar.
BTU	British Thermal Unit, an energy measurement.
Cenelec	European Electrical Code.
Compressibility Factor	A factor used to correct for the non-ideal changes in a fluid's density due to changes in temperature and/or pressure.
CSA	Canadian Standards Association.
d	Width of a bluff body or shedder bar.
D	Diameter of a flow channel.

E F G H

f	Frequency of vortices generated in a vortex flow meter, usually in Hz.
Flow Channel	A pipe, duct, stack, or channel containing flowing fluid.
Flow Profile	A map of the fluid velocity vector (usually non-uniform) in a cross-sectional plane of a flow channel (usually along a diameter).
FM	Factory Mutual.
Ft	Foot, 12 inches, a measure of length.
Ft ²	Square feet, measure of area.
Ft ³	Cubic feet, measure of volume.
gpm	Gallons per minute.
Hz	Hertz, cycles per second.

I J K L

In-Line Flow Meter	A flow meter which includes a short section of piping which is put in-line with the user's piping.
Insertion Flow Meter	A flow meter which is inserted into a hole in the user's pipeline.
Joule	A unit of energy equal to one watt for one second. Also equal to a Newton-meter.
LCD	Liquid crystal display.

M N O P

\dot{m}	Mass flow rate.
mA	Milli-amp, one thousandth of an ampere of current.
μ	Viscosity, a measure of a fluid's resistance to shear stress. Honey has high viscosity, alcohol has low viscosity.
ΔP	Permanent pressure loss.
P	Line pressure (psia or bar absolute).
ρ_{act}	The density of a fluid at the <u>actual</u> temperature and pressure operating conditions.
ρ_{std}	The density of a fluid at <u>standard</u> conditions (usually 14.7 psia and 20° C).
Permanent Pressure Loss	Unrecoverable drop in pressure.
Piezoelectric Crystal	A material which generates an electrical charge when the material is put under stress.
PRTD	An resistance temperature detector (RTD) with platinum as its element. Used because of high stability.
psia	Pounds per square inch absolute (equals psig + atmospheric pressure). Atmospheric pressure is typically 14.696 psi at sea level.
psig	Pounds per square inch gauge.
P_V	Liquid vapor pressure at flowing conditions (psia or bar absolute).

Q R S T

Q	Flow rate, usually volumetric.
Rangeability	Highest measurable flow rate divided by the lowest measurable flow rate.
Reynolds Number or Re	A dimensionless number equal to the density of a fluid times the velocity of the fluid times the diameter of the fluid channel, divided by the fluid viscosity (i.e., $Re = \rho VD/\mu$). The Reynolds number is an important number for vortex flow meters because it is used to determine the minimum measurable flow rate. It is the ratio of the inertial forces to the viscous forces in a flowing fluid.
RTD	Resistance temperature detector, a sensor whose resistance increases as the temperature rises.
scfm	Standard cubic feet per minute (flow rate converted to standard conditions, usually 14.7 psia and 20° C).
Shedder Bar	A non-streamlined body placed into a flow stream to create vortices. Also called a Bluff Body.
Strouhal Number or St	A dimensionless number equal to the frequency of vortices created by a bluff body times the width of the bluff body divided by the velocity of the flowing fluid (i.e., $St = fd/V$). This is an important number for vortex flow meters because it relates the vortex frequency to the fluid velocity.
Totalizer	An electronic counter which records the total accumulated flow over a certain range of time.
Traverse	The act of moving a measuring point across the width of a flow channel.

U V W X Y Z

Uncertainty	The closeness of agreement between the result of a measurement and the true value of the measurement.
V	Velocity or voltage.
VAC	Volts, alternating current.
VDC	Volts, direct current.
VORTEX	An eddy of fluid.