

Process Gas Mass Flow Meters and Controllers

Features

- Direct monitoring of mass flow eliminates need for ancillary pressure and temperature sensing
- Patented straight sensor tube with access ports permits easy cleaning and reduces maintenance down-time
- Platinum sensor eliminates zero-drift and ensures long-term repeatability
- Fast-response control valve provides rapid response to set point changes and operates over a wide pressure differential range
- Primary standard calibration ensures starting point accuracy and NIST traceability
- Available with a wide variety of enclosures, process connections, input/output options and control electronics
- CE Approved



SIERRA
EXPERIENCE OUR PASSION FOR FLOW!



For information online...
www.sierrainstruments.com

Side-Trak® Model 830/840



Description

Sierra Instruments' Side-Trak® Model 830 Mass Flow Meters and Model 840 Mass Flow Controllers are designed for precise measurement and control of air and process gases in ranges from 0 to 10 sccm up to 0 to 500 slpm. Because all wetted materials are 316 stainless steel, the device accommodates most clean gases, including corrosives.

Proven by over 25 years of field installations, the Side-Trak product line is distinguished by its patented, cleanable, large-diameter sensor tube and the reliability and serviceability that this feature provides. Because a microscopic layer of contamination has a major effect on small diameter sensor tubes, many mass flow meters and controllers suffer, over time, from degradation of accuracy or repeatability.

The Side-Trak sensor is not only larger in diameter than most other MFMs and MFCs, but it is mounted along the side of the flow body to provide access ports at either end. In the event of clogging or contamination, it can be cleaned with the 0.03-inch diameter cleaning rod available from Sierra.

The information contained herein is subject to change without notice.

Description (continued)

Sierra's Side-Trak® sensor also overcomes the problem of zero-drift commonly associated with capillary-type meters and controllers. Because the sensor windings are constructed of platinum, the NIST standard for temperature detection and one of the most stable elements known, the device is virtually drift-free.

Sierra's Model 840 features a built-in electromagnetic servo-control valve that provides precise, instantaneous control of gas delivery to a test, batch or continuous process operation. Speed-of-response, accuracy and reliability characterize the Model 840 and have made it the instrument of choice in a wide variety of gas flow control applications—from laboratory and test benches to instrument OEMs, in analytical and process industries, and as a transfer standard in metrology labs.

Side-Trak's broad range of sizes, control electronics, process connections, enclosures, input/output options, cables and connectors provide flexibility, versatility—ultimately, the ideal instrument package for your specific application.

Low Flow Body

FLOW RANGE	
0–10 sccm to 0–15 slpm	
Process Tubing	.25 (6.4)

FITTING TYPE, .562-18 THREAD (1)			
	Compression .125 or .25	VCO(male) .25	VCR(male) .25
Dim. L	4.84 or 5.0	4.60	4.90

Note: (1) Metric fittings are available, consult factory.

Medium Flow Body

FLOW RANGE, slpm				
	0–15	0–30	0–50, 100	0–100
Process Tubing	.25 or .375 (6.4 or 9.5)	.25 or .375 (6.4 or 9.5)	.25 or .375 (6.4 or 9.5)	.375 (9.5)

FITTING TYPE, .562-18 THREAD (1)			
	Compression .25 or .375	VCO(male) .25 or .375	VCR(male) .25 or .375
Dim. L	6.27 or 6.39	5.81 or 6.25	6.13 or 6.43

All dimensions are inches. Millimeters are in parentheses. Certified drawings are available on request.

Model 830L/840L – Front View

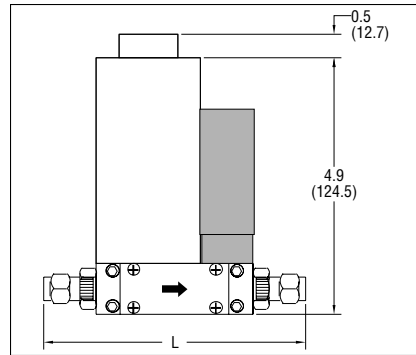

Model 830L/840L – Bottom View

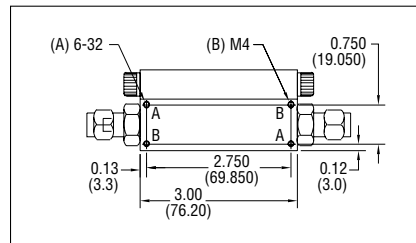

Model 830L/840L – Outlet View

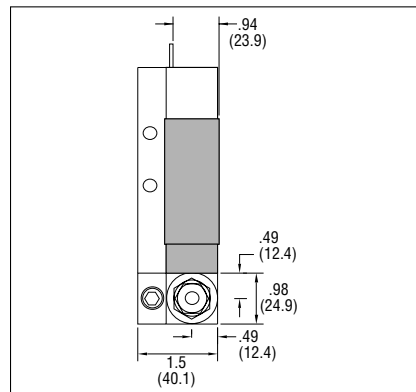

Model 830M/840M – Front View

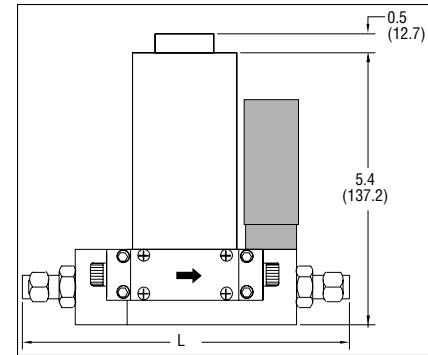

Model 830M/840M – Bottom View

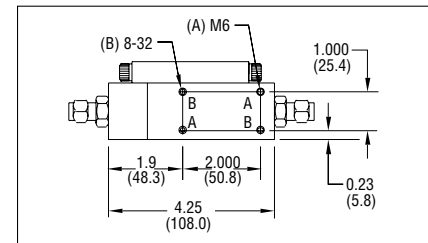

Model 830M/840M – Outlet View

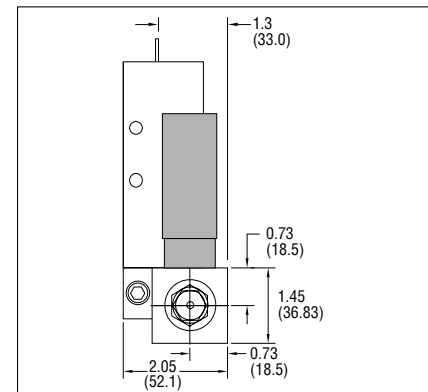

Shaded portion of dimensional drawings indicates Model 840 controllers.

Shaded portion of dimensional drawings indicates Model 840 controllers.

High Flow Body

FLOW RANGE, slpm					
	0-100	0-200	0-300	0-400	0-500
Process Tubing	.375 or .50 (9.5 or 12.7)	.375 or .50 (9.5 or 12.7)	.50 (12.7)	.50 (12.7)	.50 (12.7)
FITTING TYPE, .75-16 THREAD (1)					
	Compression .375 or .50	VCO(male) .375	VCR(male) .375		
Dim. L 830	11.90 or 12.10 (302.3 or 307.3)	11.80 (299.7)	12.19 (309.6)		
Dim. L2 840	14.10 or 14.30 (358.1 or 363.2)	14.00 (355.6)	14.40 (365.8)		

Note: (1) Metric fittings are available, consult factory.

All dimensions are inches. Millimeters are in parentheses.
Certified drawings are available on request.

Model 830H/840H – Front View

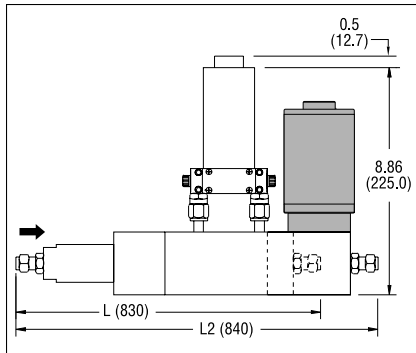

Model 830H/840H – Bottom View

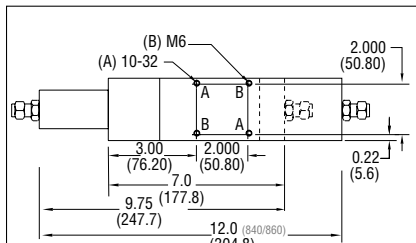

Model 830H/840H – Outlet View

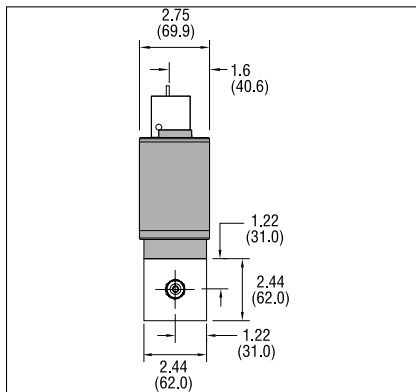

Shaded portion of dimensional drawings indicates Model 840 controllers.

Performance Specifications

Accuracy

+/- 1% of Full Scale including linearity over 15 to 25°C and 10 to 60 psia (0.7 to 4 bara); +/- 2% of Full Scale including linearity over 0 to 50°C and 5 to 150 psia (0.3 to 10 bara); +/- 1% of Full Scale accuracy at a specific temperature and pressure is available with special calibration

Inlet Pressure Deviation(2)	OPERATING PRESSURE (1)		
	50 psig	100 psig	150 psig
+/- 1 psig	+/- 1% of full scale	+/- 1% of full scale	+/- 1% of full scale
+/- 5 psig	+/- 2.5% of full scale	+/- 3% of full scale	+/- 3.5% of full scale
+/- 10 psig	+/- 4% of full scale	+/- 5% of full scale	+/- 6% of full scale

Notes: (1) Do not exceed 150 psig.

(2) Difference between inlet pressure and calibrated pressure. Do not exceed +/- 10 psig.

Repeatability

+/- 0.15% of Full Scale

+/- 0.5% of Full Scale for 840 (NPT)

Temperature Coefficient

0.08% of Full Scale per °F (0.15% of Full Scale per °C), or better

Pressure Coefficient

0.01% of Full Scale per psi (0.15% of Full Scale per bar), or better

Response Time(1)

830 (all)	300 ms time constant; 2 second (typical) to within +/-2% of set point over 20 to 100% of Full Scale
840 (low, med)	300 ms time constant; 2 second (typical) to within +/-2% of set point over 20 to 100% of Full Scale
840 (high)	600 ms time constant; 4 seconds (typical) to within +/-2% of set point over 20 to 100% of Full Scale

Notes: Option available on 840 low, medium and high flow bodies of 1.5 second time constant, others on special order.

Operating Specifications

Gases

All clean gases; specify when ordering

Mass Flow Rate

0 to 10 sccm to 0 to 500 slpm; flow ranges specified are for an equivalent flow of nitrogen at 760 mm Hg and 21°C (70°F); other ranges in other units are available (e.g., scfh or nm³/h)

Gas & Ambient Temperature

32° to 176°F (0 to 80°C); above 122°F (50°C) requires HT or RT option.

Gas Pressure

500 psig (34 barg) maximum;
30 psig (2 barg) optimum

Leak Integrity

5 X 10⁻⁹ atm cc/sec of helium maximum

Power Requirements

830 (all)	+15 VDC @ 80 mA, 1.2 watts and -15 VDC @ 10 mA, 0.15 watts
840 (low)	+15 VDC @ 130 mA, 2 watts and -15 VDC @ 200 mA, 3.0 watts
840 (med)	+15 VDC @ 400 mA, 6 watts and -15 VDC @ 300 mA, 4.5 watts
840 (high)	+15 VDC @ 1.13 A, 17 watts and -15 VDC @ 1.06 A, 16 watts

Control Range

840 (all) 2 to 100% of Full Scale;
valve shuts between 1.0% to 2.5% of Full Scale

Command Signal (For 840 Only)

0 to 5 VDC, 20 megaohms minimum input impedance
4 to 20 mA, 250 ohms maximum input impedance

Output Signal

Linear 0 to 5 VDC, 1000 ohms minimum load resistance
Linear 4 to 20mA, 500 ohms maximum loop resistance

Operating Specifications (continued)

Differential Pressure Requirements, ΔP , For Model 840

30 psi (2.1 bar) differential optimum for all controllers

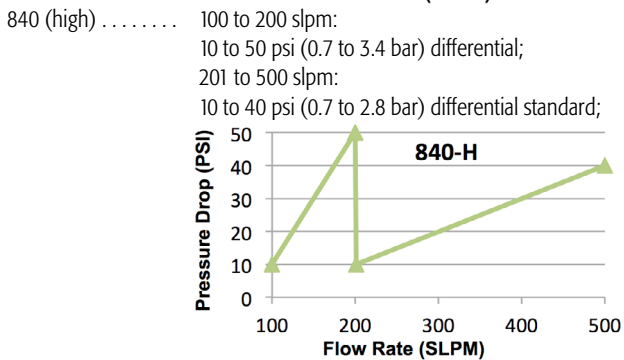
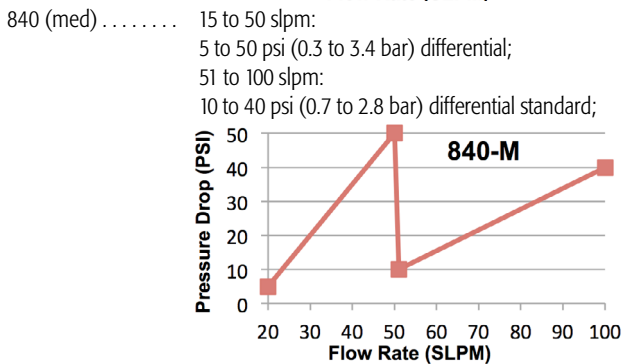
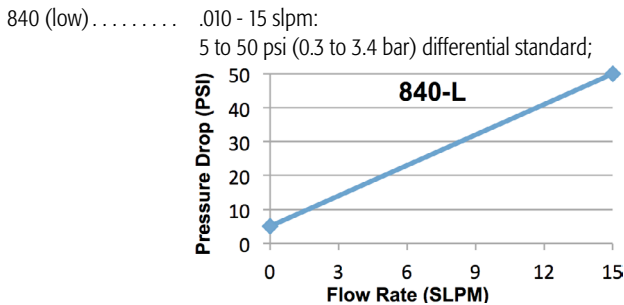

Physical Specifications

Wetted Materials

- 830 (all) 316 stainless steel, Viton® "O"-rings standard; Neoprene and 4079 Kalrez® optional; others on special order
- 840 (low, med, high) 316 stainless steel, 430F stainless steel, Viton® "O"-rings and valve seat standard; Neoprene, 4079 Kalrez® and other elastomers available on special order; PFA Teflon® valve seat available

Control Valve Type

- 840 (low, med, high) Electromagnetic

PRESSURE DROP ACROSS THE 830

Flow Meter	Flow Rate	psi			Mbar		
		1/4	3/8	1/2	1/4	3/8	1/2
	Meter Fittings (inch):						
830-L	100 sccm	.005	n/a	n/a	.309	n/a	n/a
830-L	500 sccm	.006	n/a	n/a	.440	n/a	n/a
830-L	1 slpm	.006	n/a	n/a	.475	n/a	n/a
830-L	15 slpm	.11	.06	n/a	7.59	4.0	n/a
830-M	20 slpm	.08	.03	n/a	5.50	2.0	n/a
830-M	50 slpm	n/a	.3	.10	n/a	20.4	6.8
830-M	100 slpm	2.0	.85	.30	136	58	20.4
830-H	200 slpm	n/a	2.50	2.00	n/a	170	136
830-H	500 slpm	n/a	n/a	8.5	n/a	n/a	578

Ordering the Model 830/840

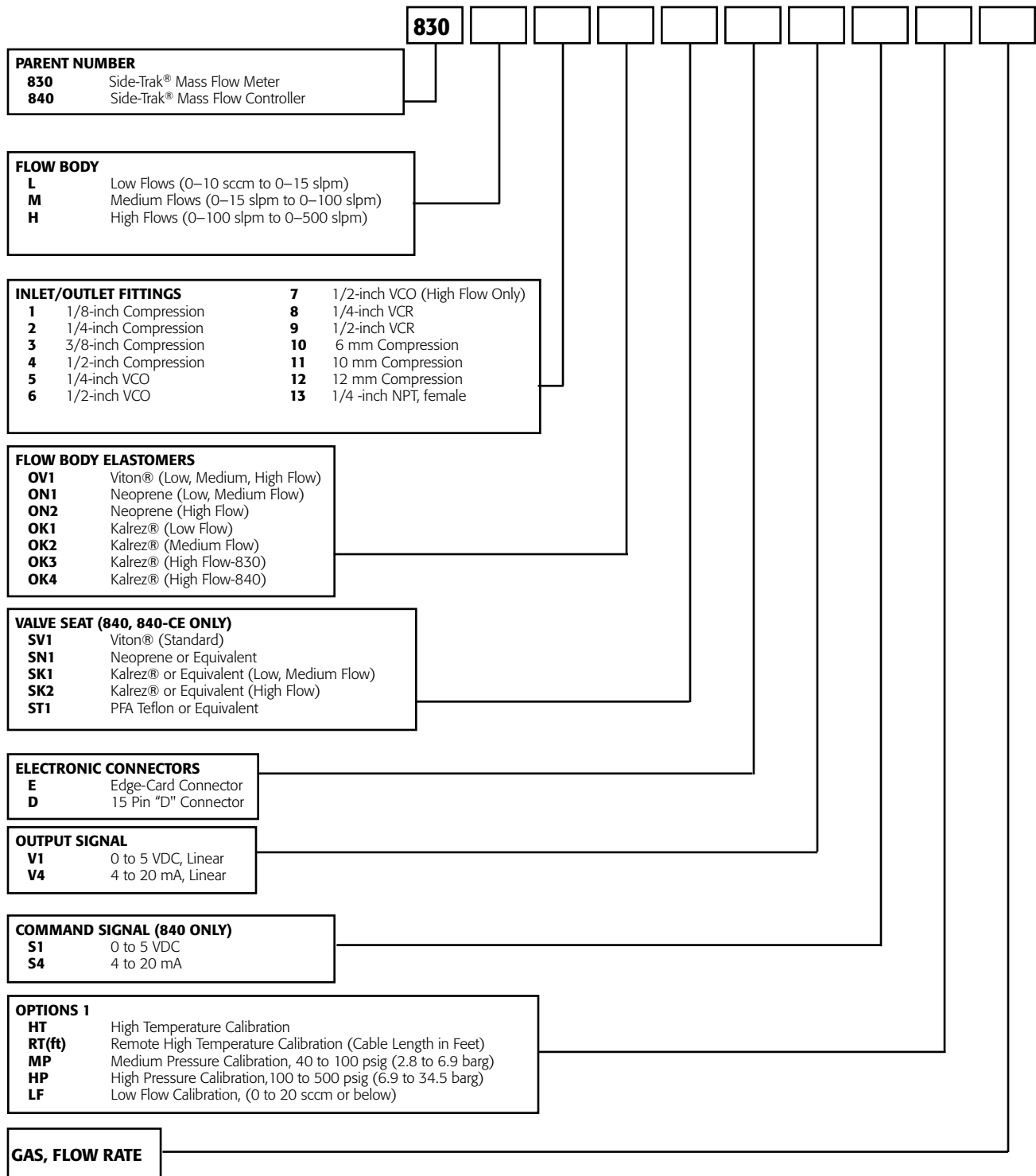

CONNECTORS, CABLES AND ACCESSORIES (Consult Factory)



SIERRA[®]
EXPERIENCE OUR PASSION FOR FLOW!

SIERRA INSTRUMENTS, NORTH AMERICA • 5 Harris Court, Building L • Monterey, California • (800) 866-0200 • (831) 373-0200 • Fax (831) 373-4402 • www.sierrainstruments.com

SIERRA INSTRUMENTS, EUROPE • Bijlmansweid 2 • 1934RE Egmond aan den Hoef • The Netherlands • +31 72 5071400 • Fax: +31 72 5071401

SIERRA INSTRUMENTS, ASIA • Rm.618, Tomson Centre, Bldg. A • 188 Zhang Yang Road • Pu Dong New District • Shanghai, P.R. China 200122 • +8621 5879 8522 • Fax: +8621 5879 8586