

Side-Trak[®] 830 & 840 Series



Instruction Manual

Part Number: IM-83/84/86, Rev. H.1

Nov. 2010



SIERRA[®]

EXPERIENCE OUR PASSION FOR FLOW!

GLOBAL SUPPORT LOCATIONS: WE ARE HERE TO HELP!

CORPORATE HEADQUARTERS

5 Harris Court, Building L Monterey, CA 93940
Phone (831) 373-0200 (800) 866-0200 Fax (831) 373-4402
www.sierrainstruments.com

EUROPE HEADQUARTERS

Bijlmansweid 2 1934RE Egmond aan den Hoef
The Netherlands
Phone +31 72 5071400 Fax +31 72 5071401

ASIA HEADQUARTERS

Rm. 618, Tomson Centre, Bldg A, 188 Zhang Yang Road
Pu Dong New District, Shanghai, P.R. China
Phone: + 8621 5879 8521 Fax: +8621 5879 8586

IMPORTANT CUSTOMER NOTICE: OXYGEN SERVICE

Sierra Instruments, Inc. is not liable for any damage or personal injury, whatsoever, resulting from the use of Sierra Instruments standard mass flow meters or controllers for oxygen gas. You are responsible for determining if this mass flow meter or controller is appropriate for your oxygen application. You are responsible for cleaning the mass flow meter or controller to the degree required for your oxygen flow application.

© COPYRIGHT SIERRA INSTRUMENTS 2010

No part of this publication may be copied or distributed, transmitted, transcribed, stored in a retrieval system, or translated into any human or computer language, in any form or by any means, electronic, mechanical, manual, or otherwise, or disclosed to third parties without the express written permission of Sierra Instruments. The information contained in this manual is subject to change without notice.

TRADEMARKS

TRADEMARKS Side-Trak™, Auto-Trak™ and Cal-Bench™ are trademarks of Sierra Instruments, Inc. Other product and company names listed in this manual are trademarks or trade names of their respective manufacturers.

Table of Contents

Chapter 1 Introduction

Introduction.....	1-1
Using this Manual.....	1-1
Safety Information.....	1-2
Receipt of System Components	1-2
Technical Assistance	1-2
The Series 800 Flow Sensing Principle.....	1-3

Chapter 2 Installation

Quick Installation Guide.....	2-1
Installation Overview	2-2
Installing the Transducer	2-3
Compression Fittings.....	2-3
VCO Fittings.....	2-3
VCR Fittings	2-4
NPT and 1/2-inch Fittings.....	2-4
Wiring the Transducer.....	2-5
Recommended Wire Gauges.....	2-5
Wiring Transducers with 20-Pin Card Edge Connectors	2-6
Wiring Transducers with 15-Pin D Connectors.....	2-10
Motor-Operated Valve Circular 10-Pin Connector.....	2-14

Chapter 3 Operation

Mass Flow Meter Operation	3-1
Mass Flow Controller Operation.....	3-2
Electromagnetic Valve Controllers	3-2
Motor-Operated Rotary Valve Controllers	3-3
Mass Flow Controller Features.....	3-4
Over-Range and Cold Sensor Lockout Circuit	3-4
Controller Auto Shut-Off Feature	3-4
On-Off Control and Soft Start Option	3-5
Valve Purge Function	3-6

Chapter 4 Maintenance

Flow Path Maintenance	4-1
Changing the Laminar Flow Element.....	4-1
Sensor Maintenance	4-6
Sensor Cleaning and Inspection	4-6
Sensor Electrical Test	4-7
Valve Maintenance.....	4-8

Electromagnetic Valves -Low and Medium Flow	4-8
Electromagnetic Valves - High Flow	4-9
Motor-Operated Rotary Valves.....	4-11
Valve Adjustment	4-12
Transducer Calibration.....	4-15

Chapter 5 Troubleshooting

Troubleshooting Procedures.....	5-1
Frequently Asked Questions	5-4
Returning Equipment to the Factory	5-7

Appendix A Conversion Formulas and Gas Tables

Appendix B Production Specifications

List of Figures

1-1. Flow Paths through the Transducer.....	1-3
1-2. Flow Measuring Principle.....	1-3
1-3. Sensor Temperature Distribution	1-4
1-4. Linear Range of the Transducer's Output Signal	1-4
2-1. Piping Requirements for NPT & 1/2-inch Connections	2-3
2-2. Input Power Connections (20-Pin Connector)	2-5
2-3. Output Signal Connections (20-Pin Connector).....	2-5
2-4. Local Command Set Point (20-Pin Connector)	2-6
2-5. External Command Set Point (20-Pin Connector)	2-6
2-6. 15 Volt Valve Purge and Off (20-Pin Connector).....	2-7
2-7. 30 Volt Valve Purge and Off (20-Pin Connector).....	2-7
2-8. Input Power (15-Pin D Connector)	2-8
2-9. Output Signal (15-Pin D Connector)	2-8
2-10. Local Command Set Point (15-PinD Connector).....	2-9
2-11. External Command Set Point (15-Pin D Connector).....	2-9
2-12. 15 Volt Valve Purge and Off (15-Pin D Connector)	2-10
2-13. 30 Volt Valve Purge and Off (15-Pin D Connector)	2-10
2-14. Motor-Operated Valve Circular 10-Pin Connector	2-11
3-1. Soft Start Response Times	3-5
4-1. Low Flow Transducer LFE Cleaning.....	4-2
4-2. Medium Flow Transducer LFE Cleaning.....	4-3
4-3. High Flow Transducer L F E Cleaning.....	4-4
4-4. NPT Transducer LFE Cleaning.....	4-5
4-5. Sensor Wire Access	4-7
4-6. Transducer Potentiometers Used for Calibration	4-12

List of Tables

2-1. Recommended Wire Gauges	2-4
------------------------------------	-----

Warnings and Cautions



Warning! Follow National Electric Code or your local code safety practices when wiring or connecting this unit to a power source. Only qualified personnel should install and wire the transducer.

Warning! Always remove main power before disassembling the transducer.



Caution! During operation, the mass flow controller valve becomes hot.

Caution! Do not use the manual purge function when RS-485 is active (Model 860 only).

Caution! Always fully neutralize any toxic gas trapped inside the transducer before removing from the gas line.

Caution! Only qualified personnel should perform transducer service, calibration or troubleshooting procedures.

Caution! Printed circuit boards are sensitive to electrostatic discharge. To avoid damaging the board, follow these precautions to minimize the risk of damage:

- before handling the assembly, discharge your body by touching a grounded, metal object
- handle all cards by their edges unless otherwise required
- when possible, use grounded electrostatic discharge wrist straps when handling sensitive components

Chapter 1 Introduction

Sierra's Side-Trak™ and Auto-Trak™ mass flow meters and controllers are designed to accurately measure and control flows of process gases. This instruction manual covers the installation, operation and maintenance of the entire Side-Trak and Auto-Trak product lines, which include the following Sierra models:

- 830 Side-Trak Mass Flow Meter
- 840 Side-Trak Mass Flow Controller
- 860M Auto-Trak Mass Flow Meter with RS-485 interface
- 860C Auto-Trak Mass Flow Controller with RS-485 interface

Sierra's mass flow meters and controllers offer a broad range of sizes, control electronics, process connections, cables and connectors for flexibility and versatility. The meter's patented straight sensor tube with access ports permits easy cleaning and reduces maintenance down-time. The platinum sensor eliminates zero-drift and ensures long-term repeatability. The primary standard calibration ensures starting point accuracy and NIST traceability. All wetted surfaces are constructed of 316 stainless steel with Viton® seals standard. Controllers incorporate either an electromagnetic valve (up to 500 slpm) or a motor-operated rotary valve (100 slpm to 200 scfm). The Auto-Trak 860 digital microprocessor features automatic bridge-balancing circuitry and provides simultaneous analog and digital RS-485 communication.

Using This Manual

This manual is organized into five chapters:

- Chapter 1 includes the introduction and theory of operation
- Chapter 2 provides installation and wiring instructions
- Chapter 3 describes system operation and controller features
- Chapter 4 covers maintenance and calibration procedures
- Chapter 5 provides troubleshooting advice

Gas tables and conversion formulas are found in Appendix A. The product specifications and dimensional drawings are found in Appendix B.

The Model 860 Auto-Trak RS-485 communications program includes an "Auto-Net" Software Addendum as a supplement to this manual. Please refer to this addendum for all RS-485 operating instructions.

Throughout this manual, we use the word *transducer* as a generic term to represent all Side-Trak and Auto-Trak mass flow meters and controllers.

Safety Information

Caution and warning statements are used throughout this book to draw your attention to important information.



Warning!

This statement appears with information that is important to protect people and equipment from damage. Pay very close attention to all warnings that apply to your application.



Caution!

This statement appears with information that is important for protecting your equipment and performance. Read and follow all cautions that apply to your application.

Receipt of System Components

When receiving a Sierra transducer, carefully check the outside packing carton for damage incurred in shipment. If the carton is damaged, notify the local carrier and submit a report to the factory or distributor. Remove the packing slip and check that all ordered components are present and match your specifications (as ordered). Make sure any spare parts or accessories are not discarded with the packing material. Do not return any equipment to the factory without first contacting Sierra Customer Service.

Technical Assistance

If you encounter a problem with your transducer, review the configuration information for each step of the installation, operation and set up procedures. Verify that your settings and adjustments are consistent with factory recommendations. Refer to Chapter 5, Troubleshooting, for specific information and recommendations.

If the problem persists after following the troubleshooting procedures outlined in Chapter 5, contact Sierra Instruments by fax or by E-mail (see inside front cover). For urgent phone support you may call (800) 866-0200 or (831) 373-0200 between 8:00 a.m. and 5:00 p.m. PST. In Europe contact Sierra Instruments bv at +31 20 6145810. When contacting Technical Support, make sure to include this information:

- the flow range, serial number and Sierra order number and model number (all marked on the transducer nameplate)
- the problem you are encountering and any corrective action taken
- application information (gas, pressure, temperature and piping configuration)

The Series 800 Flow Sensing Principle

The operating principle of Sierra's Side-Trak and Auto-Trak flow meters and controllers is based on heat transfer and the first law of thermodynamics. During operation process gas enters the instrument's flow body and divides into two flow paths, one through the sensor tube, the other through the laminar flow element bypass.

The laminar flow element bypass generates a pressure drop, $P_1 - P_2$, forcing a small fraction of the total flow to pass through the sensor tube (\dot{m}_1) which is then monitored.

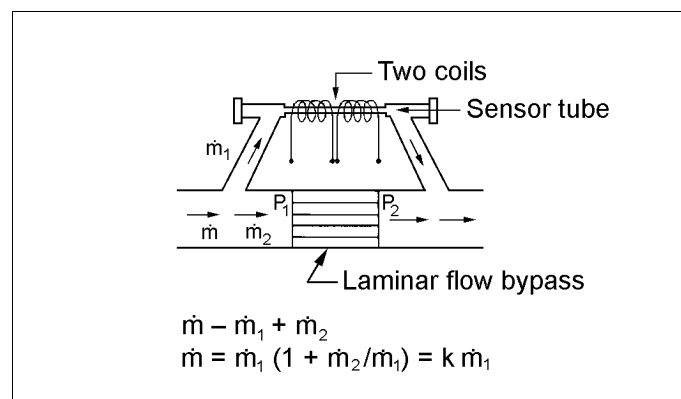

Figure 1-1. Flow Paths through the Transducer

Two resistance temperature detector (RTD) coils around the sensor tube direct a constant amount of heat (H) into the gas stream. In actual operation, the gas mass flow carries heat from the upstream coil to the downstream coil. The resulting temperature difference (ΔT) is detected by the RTD coils.

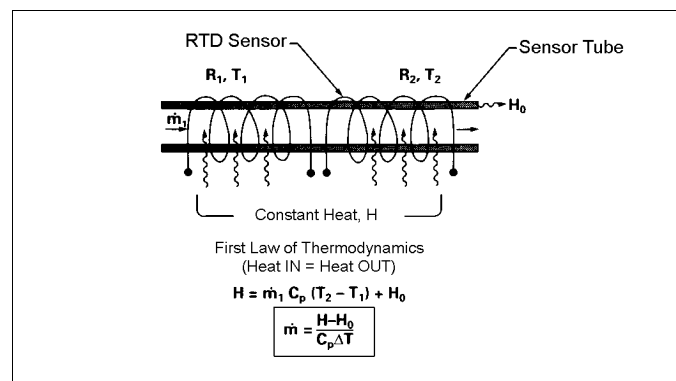

Figure 1-2. Flow Measuring Principle

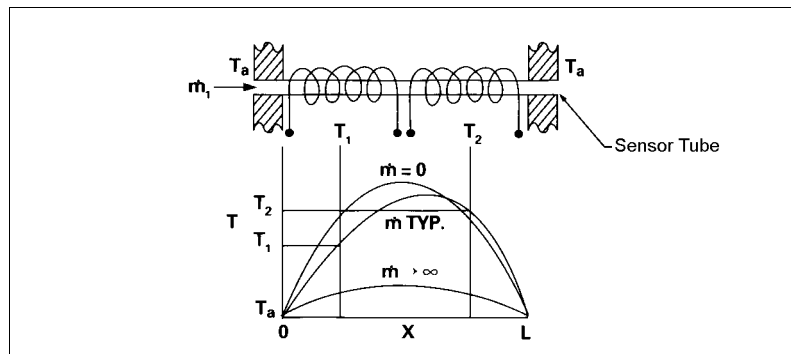

Figure 1-3. Sensor Temperature Distribution

Figures 1-2 and 1-3 show the mass flow through the sensor tube as inversely proportional to the temperature difference of the coils. The coils are legs of a bridge circuit with an output voltage in direct proportion to the difference in the coils' resistance; the result is the temperature difference (ΔT). Two other parameters, heat input (H) and coefficient of specific heat (C_p) are both constant. The resulting output is nearly linear over the transducer's normal operating range.

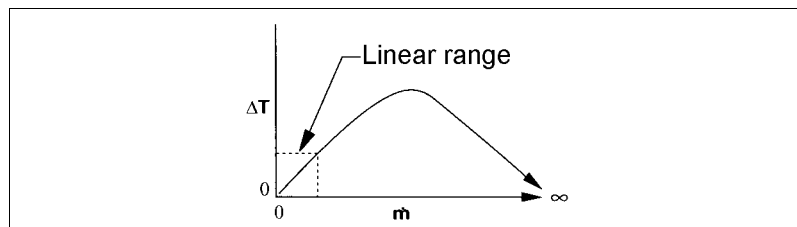

Figure 1-4. Linear Range of the Transducer's Output Signal

For mass flow *controllers*, once the gas flows through the monitoring section, it is then controlled by the built-in servo-control valve. For flows up to 500 slpm, Sierra's proprietary high-efficiency Fast-Trak Electromagnetic Valve is used. The normally closed Fast-Trak valve is similar to an on/off solenoid valve, except that the current to the valve coil, and hence the magnetic field, is modulated so that the ferromagnetic valve armature, or valve plug, assumes the exact height above the valve's orifice required to maintain the valve's command flow. The result is nearly infinite resolution. All controllers with the Fast-Trak valves are available with a "Soft-Start" option for those processes that require it.

For higher flows of 50 to 200 scfm, controllers are equipped with Sierra's microprocessor-controlled, motor-operated rotary valve. While the rotary valve does not provide a completely positive shut-off, it does offer accurate control for higher flow installations.

Chapter 2 Installation

Quick-Installation Instructions For 830/840 L, M and H Meters And Controllers

1. **NEVER TEST FOR LEAKS WITH LIQUID LEAK DETECTOR.** If liquid seeps into the electronics or the sensor compartment below, the instrument may be damaged. Use a pressure-decay test instead.
2. **Install an appropriate in-line filter upstream** if the gas contains any particulate matter or condensed moisture. (A 15-micron particulate filter for full-scale flows up to 30 liters/minute is recommended, 30 micron for flows above 30).
3. **Mount with a horizontal gas-flow.** This orientation is preferable unless the factory calibration was specifically performed for a vertical flow. Consult your calibration certificate. (Horizontal flow is assumed unless vertical flow upward or downward is specified).
4. **DO NOT APPLY POWER TO THE OUTPUT LOOP** on units equipped and calibrated for a 4-20 mA output signal. This is **NOT** a loop-powered device. Damage will occur.
5. **Wire the instrument** per the diagrams on the back of this card or the Operator's Manual, Chapter 2. Controllers require a separate ground wire for the Valve Return signal as well as a Setpoint signal (no wire connected to the setpoint may cause the valve to float open).
6. **Apply the gas** listed on the label to the inlet at the recommended inlet pressure as listed on the calibration certificate. On a meter, obtain this pressure by blocking off the flow downstream. On a controller, confirm that there is no gas flowing through it with a zero setpoint. (If there is a flow, consult the Valve Adjustment Procedure in the manual).
7. **Apply power and verify or adjust the zero setting** after allowing a 15-minute warm-up period. The zero adjustment potentiometer is accessed through the upper hole in the side of the electronics cover. (See the Operator's Manual, Chapter 3).
8. **DO NOT LEAVE A SETPOINT APPLIED TO A CONTROLLER WHEN NO GAS IS AVAILABLE TO THE INLET FITTING.** The control circuit will apply the maximum voltage to the valve coil resulting in eventual overheating. Damage may occur. (Instead, consult the Operator's Manual for use of the "Valve Off" feature).
9. An **ANNUAL factory evaluation and calibration** is recommended.

Email Technical Support: Service@sierrainstruments.com

Website Self Service: www.sierrainstruments.com

Installation Overview

Side-Trak™ and Auto-Trak™ transducers are supplied with either compression, VCO, VCR or NPT process connections. To ensure a successful installation, inlet and outlet tubing should be in a clean state prior to plumbing the transducer into the system. The shipping caps covering the inlet/outlet fittings should not be removed until immediately prior to installation.

Before installing the transducer, verify the following:

1. Make sure the installation site meets the specific operating parameters recorded on the transducer's nameplate. Each transducer is factory-configured for a specific gas and flow range, pressure differential, temperature range and mounting position.
2. Do not locate the transducer in areas subject to sudden temperature changes, moisture, drafts or near equipment radiating significant amounts of heat. Make sure to allow adequate space for cable connectors and wiring.
3. Make sure the location meets the minimum number of recommended pipe diameters upstream and downstream of any NPT or 1/2-inch process connection. A minimum of two inches is always recommended.
4. If the gas contains any particulate matter, install an in-line filter prior to the transducer. Recommended filter size: 15 micron for flows of 10 to 30 slpm, 30 micron for above 30 slpm.
5. If the transducer is mounted in any position other than horizontal and it was not calibrated specifically for that position, contact Sierra's Customer Service Department for instructions.
6. For meters, if a potential over-flow condition exists, insert a valve or critical orifice in the line to limit flow to approximately 25 percent above the full scale range of the meter.
7. For controllers, use a properly-sized pressure controller and verify the controller orifice size is the smallest in the system. There can be no restrictions (such as valves, tubing or piping internal diameters, reducers, etc.) upstream or downstream of the controller less than the valve orifice diameter.
8. Confirm that the transducer o-ring material is compatible with the gas to be measured.

Installing the Transducer



Caution!
Only qualified personnel should install the transducer.

Follow the installation instructions that are applicable to your transducer's process connection. For all NPT and 1/2-inch size fittings, see the piping recommendations given on page 2-3. Before use, all plumbing should be checked carefully for leaks and the transducer purged with dry nitrogen. Make sure that the tubing is free from burrs, or rims caused by cutting.

Compression Fittings

1. Position the transducer with the flow direction arrow pointing downstream in the direction of flow.

2. Verify the position of the front and back ferrule as shown at right. Insert the tubing into the fitting. Make sure that the tubing rests firmly on the shoulder of the fitting and that the nut is finger tight. Scribe the nut at the six o'clock position.

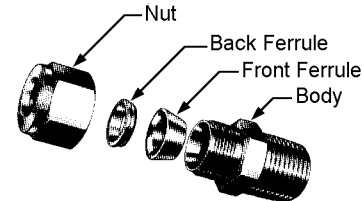

3. While holding the fitting body steady with a backup wrench, tighten the nut 1-1/4 turns, watching the scribe mark make one complete revolution and continue to the nine o'clock position. For 1/16-inch, 1/8-inch and 3/16-inch (2, 3 and 4 mm) sizes, tighten only 3/4 turn from finger tight. Do not over-tighten!
4. Check the system's entire flow path thoroughly for leaks. (Do not use liquid leak detectors, instead monitor pressure decay. Over-exposing the transducer to leak detector fluid may damage the unit.)

VCO Fittings

1. Position the transducer with the flow direction arrow pointing downstream in the direction of flow.
2. Tighten the nut finger tight, and then 1/4 turn tighter with a wrench. Do not over-tighten!
3. Check the system's entire flow path thoroughly for leaks. (Do not use liquid leak detectors, instead monitor pressure decay. Over-exposing the transducer to leak detector fluid may damage the unit.)

VCR Fittings

1. Position the transducer with the flow direction arrow pointing downstream in the direction of flow.
2. Install new washers compatible with the gas to be used. (Do not mix or interchange parts of tube fittings made by different manufacturers.)
3. Tighten the nut finger tight, and then 1/4 turn tighter with a wrench. Do not over-tighten!
4. Check the system's entire flow path thoroughly for leaks. (Do not use liquid leak detectors, instead monitor pressure decay. Over-exposing the transducer to leak detector fluid may damage the unit.)

NPT Fittings and 1/2-Inch Connections - All Types

1. Install a section of straight pipe at least five pipe diameters in length upstream of the transducer. *For flow meters only*, also allow at least two pipe diameters downstream for accurate operation. **DO NOT** use reducers.
2. Position the transducer with the flow direction arrow pointing downstream in the direction of flow.
3. Tighten fittings until leak tight (refer to published standards for specific recommendations).
4. Check the system's entire flow path thoroughly for leaks. (Do not use liquid leak detectors, instead monitor pressure decay. Over-exposing the transducer to leak detector fluid may damage the unit.)

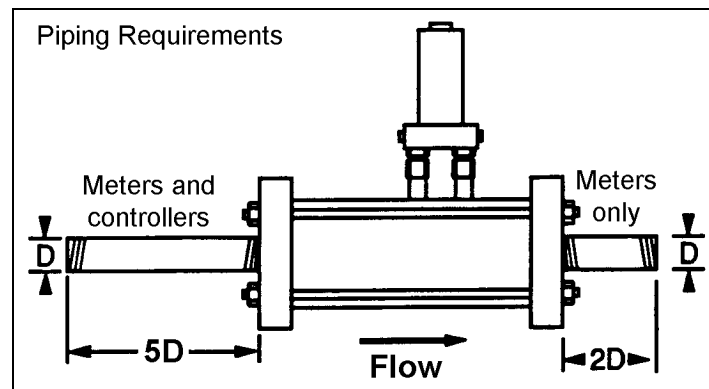

Figure 2-1.
Piping Requirements for NPT and 1/2-Inch Process Connections

**Warning!**

Follow National Electric Code or your local code safety practices when wiring or connecting this unit to a power source. Only qualified personnel should wire the transducer.

Wiring the Transducer

Side-Trak and Auto-Trak transducers require a +15, 0, -15 VDC power supply and a readout device. Additionally, controllers require a set point input (0-5 VDC standard, 4-20 mA optional). Transducers are connected to the power supply, output signal and set point control through either a 20-pin card-edge connector or 15-pin D-connector. Motor-operated rotary valves use a 10-pin circular connector. Wiring instructions are given for each type of connector on the following pages. If you are replacing another manufacturer's transducer with a Sierra product, see the factory-supplied wiring supplement for instructions specific to your installation.

Recommended Wire Gauges

Using the correct wire gauge for cabling runs to transducers enhances system reliability. For cable runs over 150 feet (46 m), consider using a local power supply.

Model 830/860M (all ranges)		
Distance in feet	Recommended Min. Wire Gauge	
25	34	
50	32	
100	28	
200	26	
300	24	
500	22	
Model 840/860C Low Flow, 15 Volt Valve		
Distance in feet	COM & -15 VDC Pins	All Others
25	30	34
50	28	32
75	26	28
100	26	28
125	24	26
150	24	26
Model 840/860C Low & Medium Flow, 30 Volt Valve		
Distance in feet	COM & -15 VDC Pins	All Others
25	26	34
50	24	32
75	22	28
100	22	26
125	20	26
150	20	26
Model 840/860C High Flow, 30 Volt Valve		
Distance in feet	+15 & -15 VDC Pins	All Others
25	22	34
50	20	32
75	18	28
100	16	26
125	16	26
150	14	26
Model 840/860C Motor-Operated Rotary Valve		
Distance in feet	+15, -15 & COM Pins	All Others
25	26	34
50	24	32
75	22	28
100	22	26
125	20	26
150	20	26

Table 2-1. Recommended Wire Gauges

Wiring Transducers with 20-Pin Card-Edge Connectors Input

Power Connections

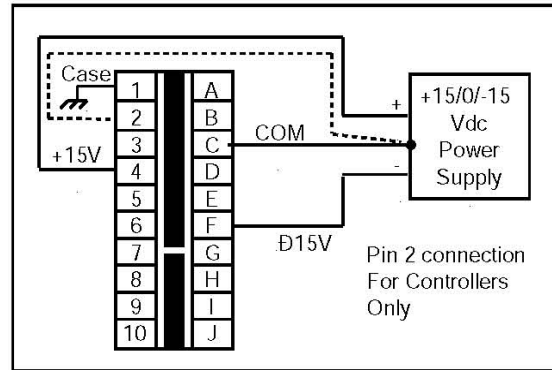

Figure 2-2. Input Power Connections (20-Pin Connector)

Output Signal Connections

Standard output for all transducers is a 0-5 V DC signal, which directly corresponds to the 0 to 100% mass flow full scale range. Output signals are linear and require a minimum load resistance of 1000 Ohms (4-20 mA output 600 Ohms maximum loop resistance).

The Auto-Trak 860 allows transmission of all available input/output signals to your computer's RS-485 communications port (connection details are given below). For additional information, refer to the "Auto-Net" Software Addendum included with this manual.

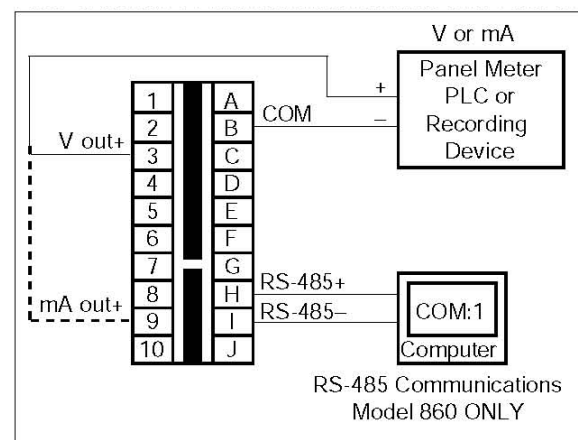

Figure 2-3. Output Signal Connections (20-Pin Connector)

- Notes:
1. Controllers require a separate, dedicated ground wire between pin 2 and the power supply common to carry the valve coil current.
 2. 4-20 mA output signal is ground-referenced ("non-isolated").
Warning: Do NOT apply any external voltage to this loop.

Input Signal Connections (Controllers Only)

The 0-5 VDC (4-20 mA optional) set point command input signal allows you to set the flow to any desired value within the range of the controller. The set point input signal is a direct linear representation of 0 to 100 percent of the controller's mass flow full scale value.

For 0-5 V DC set point control, connect a manual-adjust potentiometer as shown below. Any potentiometer value between 5K and 100K may be used but is limited to a V DC input signal only. For 4-20 mA set point control, use a 4-20 mA generator.

If the set point input is not connected to some type of control device, the valve on/off switch must be activated in the off position. If no setpoint command is present on the controller when powered-up and the valve is not switched off, the valve will drift wide open.

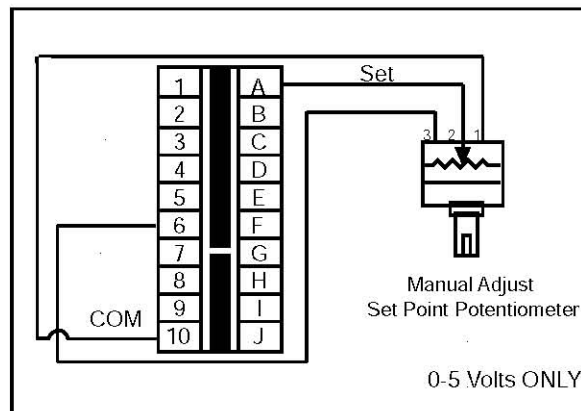

Figure 2-4.
Local Command Set Point Potentiometer (20-Pin Connector)

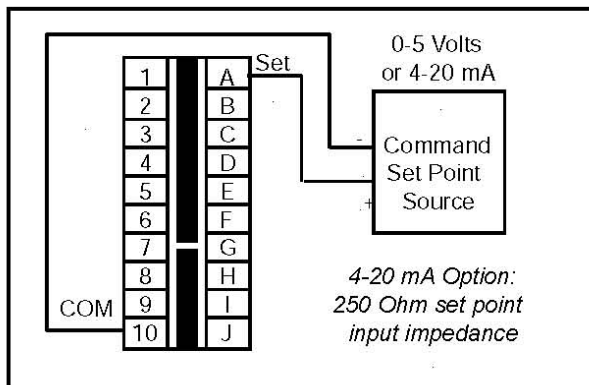

Figure 2-5.
External Command Set Point Source (20-Pin Connector)

Valve Purge and Valve Off Connections (Controllers Only)
 Depending on the valve voltage, connect as shown below.

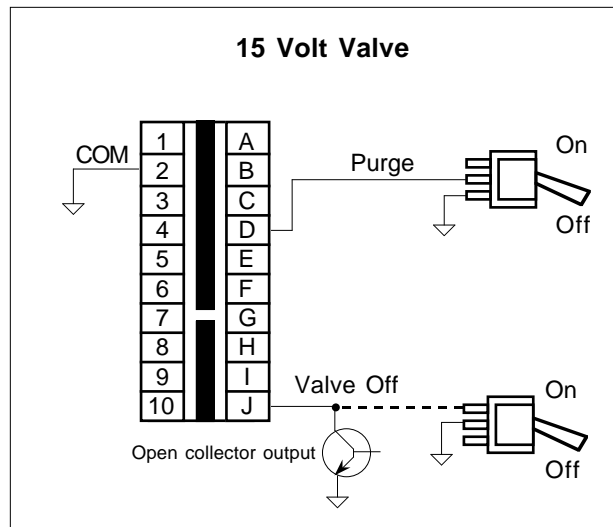

Figure 2-6.
 Valve Purge and Valve Off (20-Pin Connector)

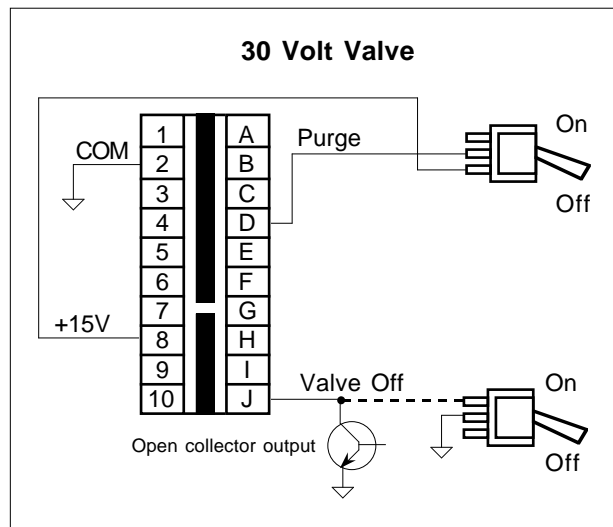

Figure 2-7. Valve Purge and Valve Off (20-Pin Connector)

Note: Typically controllers for 10 slpm or below will be equipped with a 15-volt valve circuit, while those above 10 slpm with a 30-volt circuit. Consult Technical Support if necessary.

CASE	1	A	SET
COM	2	B	COM
V OUT	3	C	COM
+15	4	D	TEST
V REF	5	E	-15
	6	F	
+15	7	G	+RS-485
4-20	8	H	-RS-485
COM	9	I	OFF
	10	J	

PIN NO.	DESCRIPTION	WIRECOLOR	
		830/840	860M/860C
1	Chassis ground	Shield	Shield
2	Common, valve return	Violet	Violet
3	Output high	White	White
4	+15 VDC supply	Red	Red
5	No connection	--	--
6	+5 VDC for local set point	--	--
7	Not avail. - connector key	--	--
8	+15 VDC	--	--
9	4-20 mA (for 4-20 mA meters only)	(White)	(White)
10	Common, input low	Gray	DD
A	0-5 VDC/4-20 mA set point input	Brown	Brown
B	Common, output low	Black	Black
C	Common, power supply	Blue	--
D	Valve test point (electromagnetic valve)	Green	Green
E	No connection	--	--
F	-15 VDC supply	Orange	Orange
G	Not avail. - connector key	--	--
H	+RS-485	--	Gray
I	-RS-485	--	Blue
J	Valve off	Yellow	Yellow

Figure 2-8. 20-Pin Connector Pin Designations

Note: Prior to 2001, sierra supplied separate cables for controllers and meters. These are now combined into one style for 830/840 devices and one style for 860M/C.

Wiring Transducers with 15-Pin D-Connectors

Input Power Connections

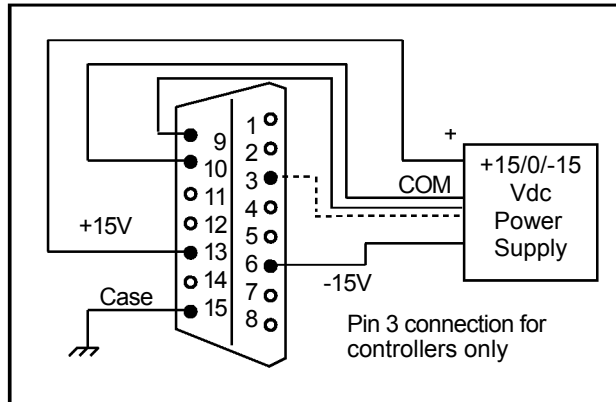

Figure 2-9. Input Power (15-Pin D-Connector)

Note: Use separate, dedicated wires for pins 9 and 10 to the power supply common on meters and pins 9, 10 and 3 on controllers.

Output Signal Connections

Standard output for all transducers is a 0-5 V DC signal, which directly corresponds to the 0 to 100% mass flow full scale range. Output signals are linear and require a minimum load resistance of 1000 Ohms (4-20 mA output 600 Ohms maximum loop resistance).

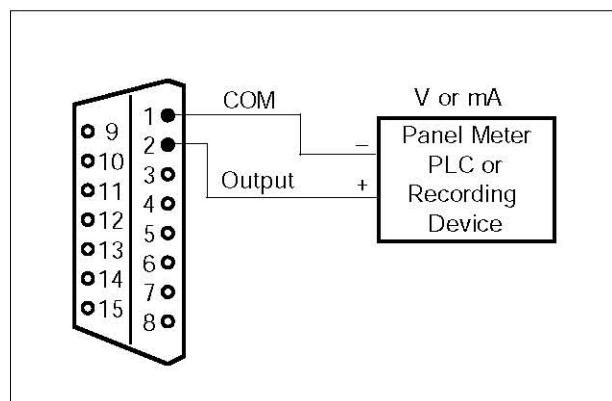

Figure 2-10. Output Signal (15-Pin D-Connector)

Notes:

1. Panel meter or read-out device should be wired to the same ground potential as the power supply.
2. 4-20 mA output signal is ground referenced (“non-isolated”).
Warning: Do not apply any external voltage to this loop.

Input Signal Connections (Controllers Only)

A 0-5 VDC (4-20 mA optional) set point command input signal allows you to set the flow to any desired value within the range of the controller. The set point input signal is a direct linear representation of 0 to 100 percent of the controller's mass flow full scale value.

For 0–5 V DC set point control, connect a manual-adjust potentiometer as shown below. Any potentiometer value between 5K and 100K may be used but is limited to a V DC input signal only. For 4-20 mA or 0–5 V DC set point control, use a PLC or other digital device.

If the set point input is not connected to some type of control device, the valve on/off switch must be activated in the off position. If no set point command is present on the controller when powered-up and the valve is not switched off, the valve will drift wide open.

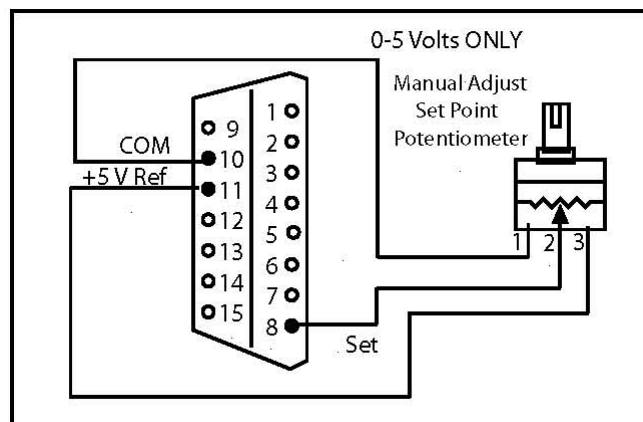

Figure 2-11.
Local Command Set Point Potentiometer (15-Pin D-Connector)

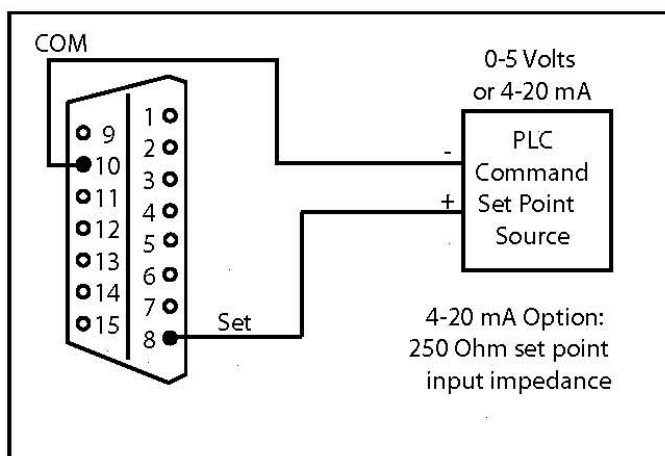

Figure 2-12.
External Command Set Point Source (15-Pin D-Connector)

Valve Purge and Valve Off Connections (Controllers Only)

Depending on the valve voltage, connect as shown below.

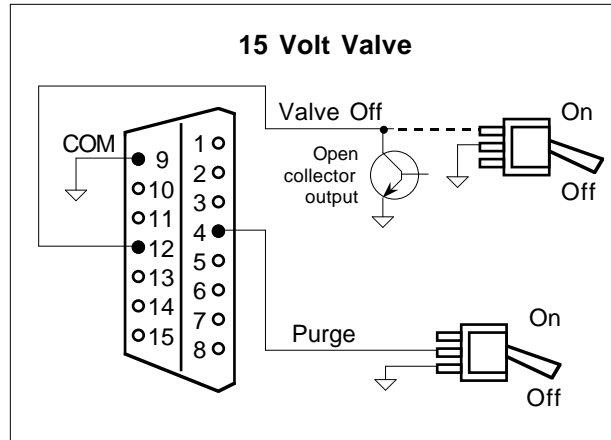

Figure 2-13. Valve Purge and Valve Off (15-Pin D-Connector)

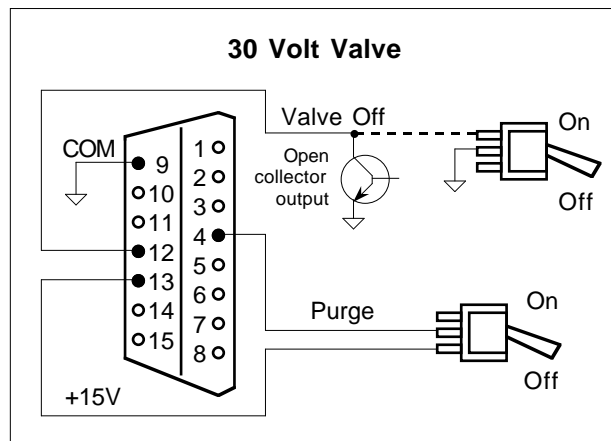

Figure 2-14. Valve Purge and Valve Off (15-Pin D-Connector)

Note: Typically controllers for 10 slpm or less will be equipped with a 15-volt valve circuit, while those above 10 slpm with a 30-volt circuit. Consult Technical Support if necessary.

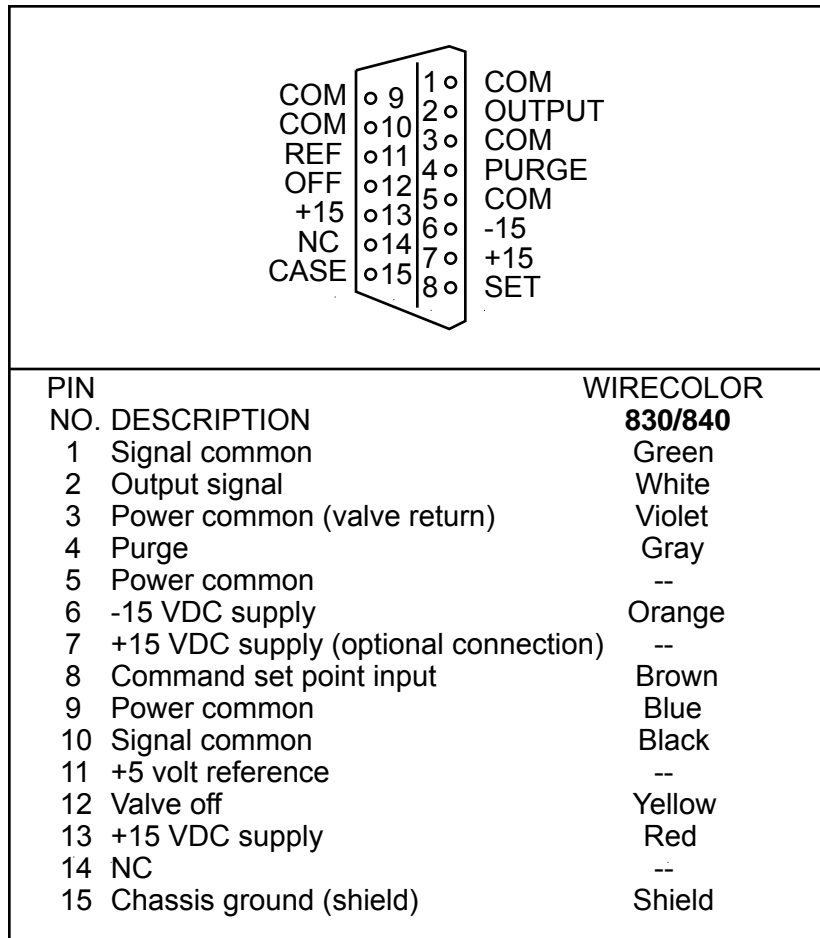

Figure 2-15. 15-Pin D-Connector Pin Assignments

NOTE: On controllers purchased or repaired after 2002, pin 3 (valve return) must have its own dedicated ground wire back to the power supply in order to operate the valve.

Motor-Operated Valve Circular 10-Pin Connector

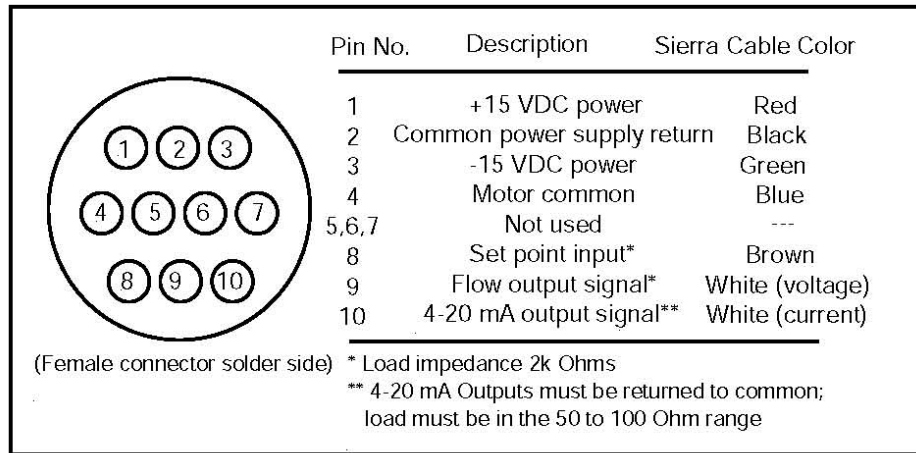

Figure 2-16. Motor-Operated Rotary Valve Connector (10-Pin Connector)

Notes:

- Both pin 2 and 4 should be connected to the power supply common via separate, dedicated wires to assure no ground loops.
- 4-20 mA output signal is ground-referenced (“non-isolated”).
Warning: Do not apply any external voltage to this loop.

Chapter 3 Operation

This chapter covers transducer operation and controller features available on Sierra's Side-Trak™ and Auto-Trak™ models. For more information on the advanced digital RS-485 commands available on Auto-Trak transducers, refer to the Series 860 "Auto-Net" Software Addendum included with this manual.

Standard output for all transducers is a linear 0-5 VDC output signal directly corresponding to 0 to 100% of the mass flow full scale range. For mass flow controllers an input signal of 0-5 VDC (4-20 mA optional) allows set point flow control to any desired value within the range of the model. The input signal is a direct linear representation of 0 to 100% of the mass flow full scale value. A 0 VDC (or 4 mA) set point will cause a condition of 0% flow to occur and a 5.00 VDC (20 mA) set point will cause a flow condition equivalent to 100% of flow to occur.

Mass Flow Meter Operation

When the transducer is installed and the system has undergone a complete leak check:

1. Apply power. Allow thirty minutes of warm-up time. (When power is first applied, the output signal from the transducer remains fixed at a much higher than normal level until the sensor warms up to its normal operating temperature range.)
2. Turn on the gas supply. Perform an initial zero output check (only required for first-time start ups). Set flow to zero. Connect a digital multimeter to V+out (4-20 mA out) and COM terminals.
3. Check the reading. If it is not within ± 10 mV (± 0.10 mA) of zero, adjust the zero potentiometer to zero the transducer. (The zero pot is located behind the upper metal button on the side of the transducer or behind the swing-out plastic door.)

Mass Flow Controller Operation

Electromagnetic Valve Controllers



Caution!

During operation, the mass flow controller valve becomes hot.

When the transducer is installed and the system has undergone a complete leak check:

1. Make sure the set point is zero before applying power. If the set point input is not connected to some type of control device, set the valve on/off switch in the off position. (No connection may cause the setpoint to float). Note: The valve opens momentarily when power is first applied.
2. Apply power. Allow thirty minutes of warm-up time. (When power is first applied, the output signal from the transducer remains fixed at a much higher than normal level until the sensor warms up to its normal operating temperature range.)
3. Turn on the gas supply. Perform an initial zero output check (only required for first-time start ups). Set flow to zero. Connect a digital multimeter to V+out (4-20 mA out) and COM terminals.
4. Check the reading. If it is not within ± 50 mV (± 0.16 mA) of zero, adjust the zero potentiometer to zero the transducer. (The zero pot is located behind the upper metal button on the side of the transducer or behind the swing-out plastic door.)
5. Adjust the controller set point to the desired flow rate.

Caution: Never leave the controller with no gas supply while supplying a setpoint. The valve will open to its maximum position and eventually overheat causing possible damage to the control circuit. If it is desired to interrupt the gas flow for an extended period, consider utilizing the “Valve-Off” circuit.

Motor-Operated Rotary Valve Controllers

When the transducer is installed and the system has undergone a complete leak check:

1. Make sure the valve set point is zero before applying power.
2. Apply power. Allow thirty minutes of warm-up time. (When power is first applied, the output signal from the transducer remains fixed at a much higher than normal level until the sensor warms up to its normal operating temperature range.)
3. Turn on the gas supply. Verify that no flow exists. Perform an initial zero output check (only required for first-time start ups). Set flow to zero. Connect a digital multimeter to V+out (4-20 mA out) and COM terminals.
4. Check the reading. If it is not within ± 10 mV (± 0.10 mA) of zero, adjust the zero potentiometer to zero the transducer. (The zero pot is located behind the upper metal button on the side of the transducer or behind the swing-out plastic door.)
5. Adjust the controller set point to the desired flow rate.

All motor-operated rotary valves seek a “deadband” where the flow is identical to the set point within specified tolerances. Keep this in mind when checking the instrument’s performance. For instance, a 100 scfm flow controller may have a set point of 2.500 volts (50 scfm) and a flow indication of 2.550 volts (51 scfm). This controller is working correctly, since the difference between the flow and the set point is within 1 scfm, which is the specified accuracy of $\pm 1\%$ of full scale ($0.01 \times 100 \text{ scfm} = 1 \text{ scfm}$). The width of the deadband varies with the valve size and range of each controller.

During operation, the motor runs only when it needs to. If the pressure differential across the valve is insufficient to obtain set point, the valve will open fully and the motor will cease to run. Conversely, if the set point is zero, the valve will close, and the motor will cease to run. In either case, there will be no control action. Check for adequate pressure differential and that set point command voltage is present at the motor operator connector.

Mass Flow Controller Features

Over-Range and Cold Sensor Lockout Circuit

Side-Trak Models incorporate an over-range circuit which disables the output signal when the sensor is heating to its normal operating range, or if an over flow condition exists. The operation of this circuit can be verified by observing the 5 VDC (20 mA) output signal during power up.

The cold sensor lockout safety circuit automatically closes the valve if a fault condition is detected that could result in uncontrolled flow (valve wide open). The circuit operates by monitoring the temperature of the sensor elements. If the temperature falls below a preset limit the circuit forces the output signal to a fixed high level which disables the output signal. The cold sensor lockout circuit is enabled during initial start-up. This feature is not available if liquid is present in the flow path.

There are several conditions which could trigger the cold sensor lockout circuit:

1. Operation at a temperature below the instrument's rating.
2. Power failure while running at or near full scale. Upon resumption of power, the valve will remain closed until the minimum operating temperature is again reached.
3. Sensor failure.

If needed, the cold sensor lockout circuit and/or over-range indicator can be disabled by removing CR1 from the main 830 circuit board.

Controller Auto Shut-Off Feature

All flow controllers are normally provided with an Auto Shut-Off feature that closes the valve at a command signal level of approximately 2% of full scale, or less. (All electromagnetic valves fail normally-closed). On 840 controllers, this value can be reduced. Contact the factory for details on this option.

On-Off Control and Soft Start Option

On-off control is provided for all models equipped with an electromagnetic valve. This feature is available by connecting a manual on-off switch to the transducer connector as shown in Chapter 2.

Certain processes cannot tolerate the normally fast response of Sierra mass flow controllers. In these cases a “soft start” circuit slows the mass flow controller’s valve response characteristics to avoid any bursts of flow that could disrupt a delicate process or perhaps stir up particulate.

The standard soft start time constant is 1.5 seconds, providing a 7.5 second response time to within 2 percent of final value. The time constant is factory-set to fit your exact requirements.

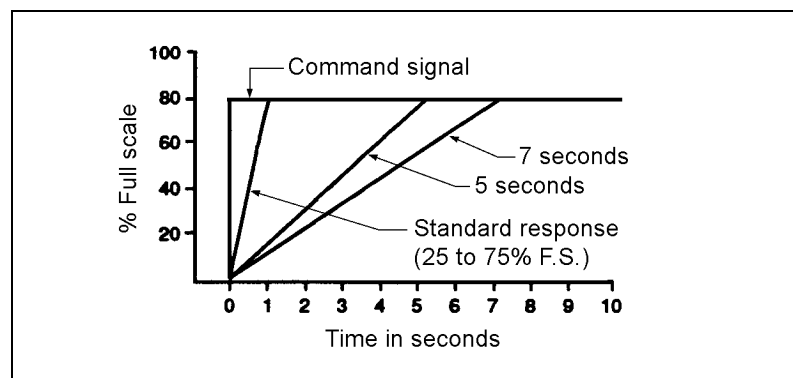

Figure 3-1. Soft Start Response Times



Caution!

Do not use the manual valve-off feature when RS-485 is active.

The Model 860 provides valve on-off and soft start control with either the manual hardware option, or with digital (software) control via RS-485. For more information, refer to the Series 860 “Auto-Net” Software Addendum.

Valve Purge Function

Electromagnetic valves are driven with either 15 or 30 volts depending on the range and pressure. In general, units below 10 slpm have the 15 volt valve. When the purge function occurs, electromagnetic valves are driven fully open regardless of the set point input. Furthermore, the purge function will override any valve-off function. This option is not available on motor-operated rotary valves. Motor-operated valves are purged by setting the command signal to full scale. There is no equivalent monitor function.



Caution!

Do not use the manual purge function when RS-485 is active.

The Model 860 allows valve monitoring and the purge function to be utilized in either analog or digital (RS-485) mode. If both hardware and software control options are used simultaneously on an 860, conflicts may occur that can produce undesired results.

For +15 Volt Valve Controllers: The valve purge function is activated when the Valve Test Point/Purge connection is connected to ground. The maximum valve voltage is indicated in the “comments” field of the calibration certificate. (Units with ranges below 10 slpm)

For +30 Volt Valve Controllers: The valve purge function is activated when the Valve Test Point/Purge connection is connected to +15 VDC. The maximum valve voltage is indicated in the “comments” field of the calibration certificate.

A Sierra controller intended as a replacement for another manufacturer’s controller may have Pin D and other pins disconnected. Some options may not be available.

Purging Non-Reactive Gases:

Purge the transducer with clean, dry nitrogen for a minimum of two hours.

Purging Reactive Gases:

One of the following methods may be used:

- Cycle purge. This is done by alternately evacuating and purging the transducer for two to four hours with clean, dry nitrogen.
- Purge the transducer with clean, dry nitrogen for eight to twenty-four hours.
- Evacuate the transducer for eight to twenty-four hours.



Caution!

Always fully neutralize any toxic gas trapped inside the transducer before removing from the gas line.

When toxic or corrosive gases are used, purge unit thoroughly with inert dry gas before disconnecting from the gas line. If a transducer used with a toxic or corrosive gas is returned to the factory, a Ma-

terial Safety Data Sheet must be enclosed with the unit upon its return.

Chapter 4 Maintenance



Caution!

It is important that this transducer be serviced only by qualified personnel.

Side-Trak™ and Auto-Trak™ transducers essentially require no scheduled maintenance other than periodic flow path cleaning if the gas is dirty. If an in-line filter is used, the filtering element should be periodically be replaced or ultrasonically cleaned. Included in this chapter are general instructions for:

- Flow Path Maintenance page 4-1
- Sensor Maintenance..... page 4-6
- Valve Maintenance..... page 4-8
- Valve Adjustment..... page 4-12
- Transducer Calibration page 4-15

Flow Path Maintenance



Caution!

Always fully neutralize any toxic gas trapped inside the transducer before removing from the gas line.

The transducer flow path is 316 stainless steel (wetted magnetic parts of the solenoid valve are 430F stainless steel) with Viton® Neoprene® or Kal-Rez® (or equivalent) seals, depending on the gas used. The flow path should be periodically inspected and cleaned as required.

When toxic or corrosive gases are used, purge unit thoroughly with inert dry gas before disconnecting from the gas line. A transducer used with toxic or corrosive gas must NOT be returned to the factory. Contact Technical Support for details.

Cleaning the Laminar Flow Element

The laminar flow element (LFE) is a precision flow divider which diverts a preset amount of flow through the sensor tube. The LFE is made of precision machined 316 stainless steel. The particular LFE used depends on the gas and flow range of the instrument and is identified by the number on the transducer nameplate. Should the LFE require cleaning or inspection due to deposition, use the appropriate cleaning procedure given on the following pages.



CAUTION! : REMOVING THE LFE WILL SHIFT THE CALIBRATION OF THE INSTRUMENT. *DO NOT* REMOVE THE LFE UNLESS YOU PLAN ON RE-CALIBRATING THE TRANSDUCER.

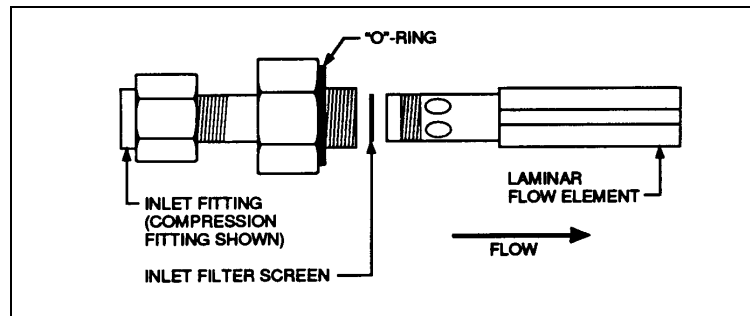

Figure 4-1. Low Flow Transducer LFE Cleaning

Low Flow Transducers:

The LFE is accessed by unscrewing the main inlet fitting and removing it from the flow body. The LFE is screwed into the inlet fitting, which has been specially machined for this purpose. To access the components:



Caution!
Removing or re-positioning the LFE may alter the calibration..

1. Remove the unit from the system.
2. The inlet filter screen is held in place in the inlet fitting by the LFE. Disassemble by holding the fitting steady with a wrench and unscrewing the LFE with a medium flat-tipped screwdriver.
3. Remove the LFE assembly taking care not to bend the inlet screen. Inspect the sealing O-ring and replace if necessary. Inspect the inlet screen and replace if corroded or damaged. Light to medium particulate contamination can be cleaned by back washing with a suitable solvent. Air dry thoroughly.
4. Inspect the LFE for damage and replace if necessary. Replacement of the LFE or inlet screen requires transducer recalibration.
5. Re-assemble components. When the transducer is re-installed in the system, leak test the connection.
6. Check transducer calibration.

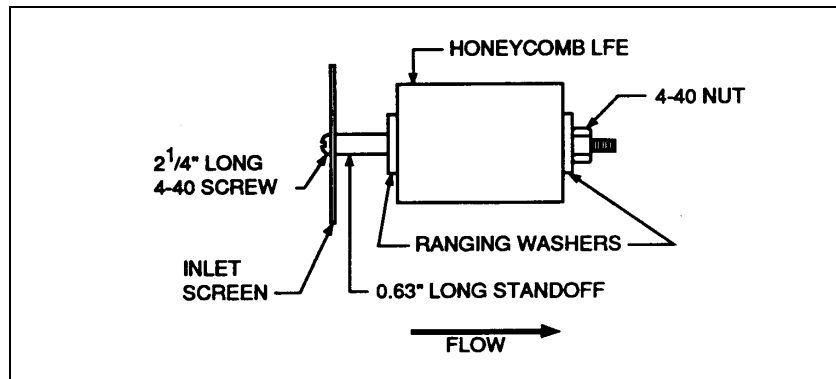

Figure 4-2. Medium Flow Transducer LFE Cleaning

Medium Flow Transducers:

In the medium flow body, the LFE assembly consists of the honeycomb laminar flow element, inlet screen, 0.63 inch long standoff, two ranging washers, 2-1/4 inch long 4-40 screw and 4-40 nut. Range changes in the honeycomb element are made with various diameter ranging washers. To access the components:

7. Remove the unit from the system.
8. Access the LFE by unscrewing the four 10-32 socket head cap screws from the inlet side of the flow body and remove the inlet end cap.
9. Remove the LFE assembly taking care not to bend the inlet screen. Inspect the sealing O-ring and replace if necessary. Inspect the inlet screen and replace if corroded or damaged. Light to medium particulate contamination can be cleaned by back washing with a suitable solvent. Air dry thoroughly.
10. Inspect the honeycomb element for damage and replace if necessary. Replacement of the LFE or inlet screen requires transducer re-calibration.
11. Re-assemble components. When the transducer is re-installed in the system, leak test the connection.
12. Check transducer calibration.

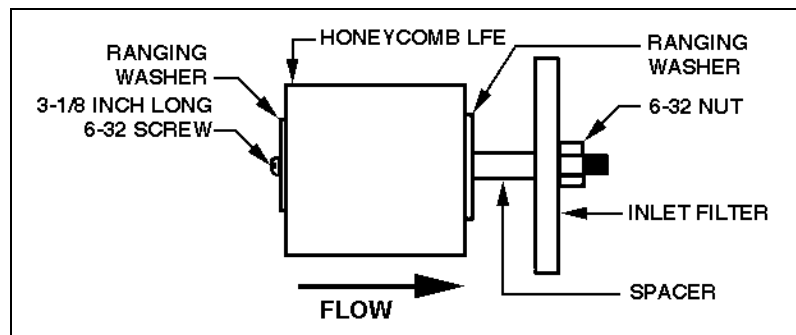

Figure 4-3. High Flow Transducer LFE Cleaning

High Flow Transducers:

The high flow LFE is similar to the honeycomb element used in the medium flow body but larger in diameter. The high flow body consists of four parts: inlet tube, inlet cap, main flow body and end cap. The inlet tube is only removed to inspect and replace the sealing O-ring between the inlet tube and inlet cap. To access the components:

1. Remove the unit from the system.
2. To remove the inlet screen, remove the four 1/4-28 socket head cap screws on the inlet side of the flow body and separate the inlet cap from the main flow body.
3. Inspect the inlet screen for damage and corrosion and replace if necessary. Light to medium particulate contamination can be cleaned by back washing with a suitable solvent. Air dry thoroughly.
4. Inspect the sealing O-ring for damage and replace if necessary. The inlet screen is mounted with the fine mesh side facing the inlet.
5. To remove the LFE loosen and remove the four threaded rods holding the end cap to the main flow body. Separate the end cap from the main flow body and remove the LFE assembly. The LFE assembly consists of: 6-32 x 31/8 inch long screw, a #6 washer, two ranging washers, honeycomb LFE, spacer, inlet filter and 6-32 nut.
6. Inspect the honeycomb element for damage and replace if necessary. Replacement of the LFE or inlet screen requires transducer recalibration.
7. Re-assemble components. When the transducer is re-installed in the system, leak test the connection.
8. Check transducer calibration.

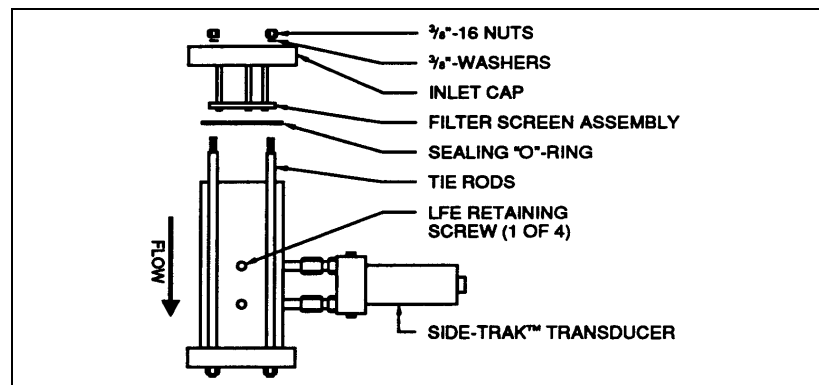
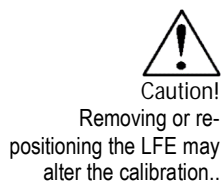

Figure 4-4. NPT Transducer LFE Cleaning

NPT-Type Transducers:

The NPT flow body is comprised of a stainless steel pipe terminated on either end by an end cap sealed with an O-ring. The end caps are held in place by four tie rods which run the length of the flow meter and are fastened with eight 3/8-16 nuts and washers. The inlet screen is mounted to the inside of the inlet end cap on three standoffs. The LFE is a cylindrical honeycomb element located in the flow body between the two sensing ports. In most cases, the LFE can be cleaned without removing it from the flow body. If it cannot be cleaned by back washing, return for factory service. To access the components:



1. Remove the unit from the system.
2. To remove the inlet filter screen, stand the flow body on end with the inlet facing up and remove the four 3/8-16 nuts on the ends of the tie rods. Carefully lift the end cap and filter screen assembly up and off the meter.
3. Inspect the inlet screen for damage and corrosion and replace if necessary. Light to medium particulate contamination can be cleaned by back washing with a suitable solvent. Air dry thoroughly before re-assembly. Mount the inlet screen with the fine mesh side facing the inlet.
4. Inspect the sealing O-ring for damage and replace if necessary.
5. Re-assemble components. When the transducer is re-installed in the system, leak test the connection.
6. Check transducer calibration.



Caution!

Do not remove the sensor cover, this could shift transducer calibration.

Sensor Maintenance

The sensor tube is straight and has a relatively large, 0.031 inch ID, which makes inspection and cleaning easy. Sensor maintenance consists of:

- inspecting and cleaning the sensor flow path
- checking the sensor for proper electrical function

Sensor Cleaning and Inspection

Cleaning is accomplished by simply rodding out the sensor with the Sensor Cleaning Stylette, part number “CK”, available from Sierra for this purpose. (A 0.020 inch to 0.028 inch diameter piano wire may also be used.) To access the sensor for inspection or cleaning:



Caution!

When using toxic or corrosive gases, purge the unit thoroughly with inert dry gas before disconnecting from the gas line.

1. Remove the unit from the system.
2. Remove the two socket head access port plugs with a 1/4 inch Allen wrench.
3. Visually inspect the sensing ports and sensor.
4. Use a hemostat or tweezers to push the cleaning wire into the downstream opening of the sensor tube. Do not force the cleaning wire; move it back and forth—DO NOT TWIST OR ROTATE.
5. Flush the sensor tube with a non-residuous solvent. In cases where solids are deposited in sensor, units should be returned to factory for complete cleaning and re-calibration.
6. Blow dry all parts with dry nitrogen and re-assemble.
7. When the transducer is re-installed in the system, leak test the connection.
8. Check transducer calibration.

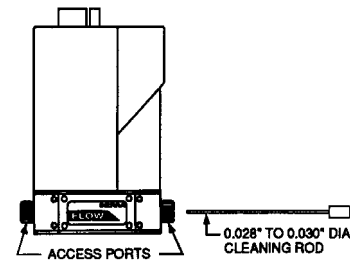

Sensor Electrical Test

To check the electrical integrity of the sensor windings:



***Important note:** Removal of the sensor cover and disturbance of sensor insulation blanket that is inside will alter the sensors performance, will necessitate a re-calibration, and may break the sensor micro-weldings.

1. Remove the unit from the system.
2. Remove the two 4-40 Phillips head screws located on top of the electronics enclosure and slide the enclosure up and off. Use a nut driver to remove the two standoffs supporting the printed circuit boards. Tilt the boards to access the three sensor wires as shown below.
3. Locate the black, red and white wires connecting the sensor to the main circuit board.
4. Connect one lead of an Ohm meter to the white wire and measure the resistance between the red and white wires. Next, measure the resistance between the black and white wires. These readings should each be approximately 50 Ohms. Low or zero Ohm readings on either indicates a short circuit. High or infinite Ohms readings indicate an open circuit.
5. Next, measure the resistance between the case (metal part of the flow body) and any one of the sensor wires. This reading should be 2 Megohms or greater. Incorrect readings require sensor replacement and re-calibration.
6. When the transducer is re-installed in the system, leak test the connection. Check transducer calibration.

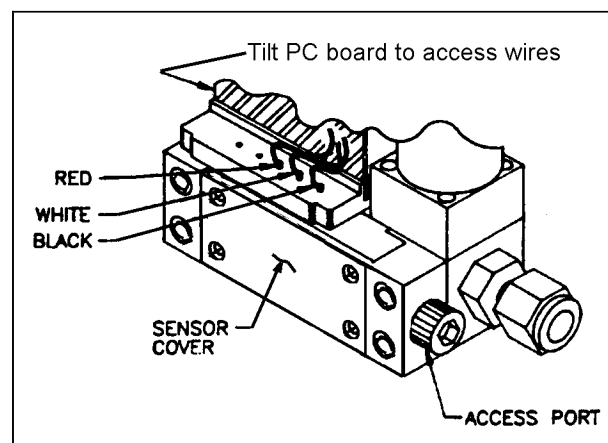

Figure 4-5. Sensor Wire Access

Valve Maintenance

Electromagnetic valves may require spring-tension adjustments for various reasons (See Valve Adjust Procedure). No maintenance is required under normal operating conditions other than an occasional cleaning. Use of certain corrosive gases may require frequent replacement of the valve plug and O-rings. This indicates a need for a different elastomer. Viton is standard, with Neoprene, Kal-Rez (or equivalent), and PFA Teflon offered as options.

Do not attempt any valve adjustments while the meter is “on-line” with any dangerous gas. All controllers should be thoroughly leak-tested following any valve adjustment.

For the Model 860 Auto-Trak, refer to “Piston Tube Calibration Procedure” for instructions on how to re-adjust the electromagnetic valve for proper operation.

Electromagnetic Valves - Low and Medium Flow Controllers

Controllers with a low or medium flow body use the same valve; high flow models use a larger version. Cleaning can often be accomplished by opening the valve, using the purge function and flushing in both directions. Alternatively, the valve may be manually opened by loosening the 6-32 lock nut on top of the valve and turning the adjustment screw fully counterclockwise.

To disassemble the low and medium flow valve for inspection:

1. Remove the unit from the system.
2. Remove the two 4-40 Phillips head screws on top of the enclosure. Remove the enclosure by sliding it up and off. Remove the metal cap on top of the valve by inserting a flat tip screwdriver into the slots provided and prying upward.
3. Use a 5/8 inch nut driver to loosen and remove the 5/8 inch nut at the top of the valve. Remove the coil, coil enclosure and warp washer.



Caution!

When using toxic or corrosive gases, purge the unit thoroughly with inert dry gas before disconnecting from the gas line.

4. The small circuit board may be separated from the main board to ease removal of the coil. To separate, first remove the plastic #4 mounting screw located in the center of the main circuit board and carefully pull the two boards apart. Remove the four 4-40 socket head cap screws at the base of the valve. Separate the valve from the flow body.
5. There are three O-rings sealing the valve assembly: one between the base and the flow body, one under the valve seat (orifice), and one on the top adjusting screw inside the valve. Inspect the O-rings for damage and replace as necessary. (You should replace all O-rings whenever the valve is disassembled.)
6. Inspect the valve seat and plug for corrosion or roughness and replace as necessary.
7. Re-assemble components. Note: the 5/8 inch nut must not be tightened with more than 10 in-lb of torque.
8. When the controller is re-installed in the system, leak test the connection.
9. Adjust the valve for proper operation as given in the controller valve adjustment procedure.

Electromagnetic Valves - High Flow Controllers

The high flow electromagnetic valve is similar in design to the low flow valve. As with the low flow valve, cleaning can often be accomplished by opening the valve using the purge function and flushing in both directions. Alternatively, the valve may be manually opened by loosening the 6-32 lock nut on top of the valve and turning the adjustment screw fully counterclockwise.

To disassemble the high flow valve:

1. Remove the unit from the system.
2. Remove the two 4-40 Phillips head screws from the top of the enclosure. Remove the enclosure by sliding it up and off. Remove the metal cap on top of the valve by inserting a flat tip screwdriver between the two parts and lifting upward.



Caution!

When using toxic or corrosive gases, purge the unit thoroughly with inert dry gas before disconnecting from the gas line.

3. Unscrew the coil cover with a 11/16 inch wrench. Remove the coil and coil enclosure. Note the location of any washers or spacers for re-assembly.
4. The small circuit board may be separated from the main board to ease removal of the coil. To separate, first remove the mounting screw located in the center of the main circuit board and carefully pull the two boards apart.
5. Remove the four 1/4-28 socket head cap screws at the base of the valve. Separate the valve from the flow body, taking care not to lose any small parts.
6. There are three O-rings sealing the valve assembly: one between the base and the flow body, one under the valve seat (orifice), and one on the top adjusting screw inside the valve. Inspect the O-rings for damage and replace as necessary. (You should replace all O-rings whenever the valve is disassembled.)
7. Inspect the valve seat and plug for corrosion or roughness and replace as necessary.
8. Re-assemble the components. When the controller is installed in the system, leak test the connection.
9. Adjust the valve for proper operation as given in the controller valve adjustment procedure.

Motor-Operated Rotary Valves

The electronic components in the Model 840 motorized valve flow controllers require no maintenance with the exception of the motor, which requires replacement when its service life has ended. This will be evidenced by “hunting,” or the inability to maintain set point without a constant motion back and forth, or outright failure. The motor normally has a long service life, typically more than five years, and all other possibilities should be explored before considering replacement.

To disassemble the motor-operated rotary valve:



Caution!

When using toxic or corrosive gases, purge the unit thoroughly with inert dry gas before disconnecting from the gas line.

1. To allow for component removal, set the valve to the fully open position before removing power.
2. Remove the unit from the system.
3. If desired, remove the valve from the flow body to make disassembly easier. Unplug the connector and remove the four bolts holding the valve assembly to the flow body. Inspect the sealing O-ring and replace as necessary.
4. Unscrew the six 4-40 Phillips head screws from the valve motor enclosure and remove the lid. Loosen the lower set screws in the motor shaft coupling (there are two set screws in each location to prevent loosening during operation). Inspect the valve rotor shaft and coupling for scoring and replace if necessary.
5. Remove the three 8-32 screws holding the valve to the enclosure and separate the valve body from the enclosure.
6. Unscrew the four 6-32 x 7/8 inch flat head screws from the top of the valve and remove the valve base plate and spacer. Remove the valve bonnet, rotor and Teflon washers. Inspect the valve rotor and body for wear and replace the O-ring and seal in the valve bonnet.
7. Inspect and replace the Teflon valve leaves and upper and lower Teflon washers if they are worn or damaged.
8. Re-assemble the components. When the controller is re-installed in the system, leak test the connection.

840 L, M and H series Valve Adjustment Procedure

The Sierra 840 L, M and H (low, medium or high-flow units) control the flow with a proportional electromagnetic valve that is set up for certain process conditions. Variables, which affect their operation, include orifice size, spring selection and adjustment, input and output pressures and gas-flow orientation (horizontal or vertical). If operating conditions change it may be necessary to make a valve spring adjustment. An adjustment may also become necessary due to a valve-seat depression or spring sag, both of which can cause a change in the internal tension of the valve spring and electrical current. An incorrectly adjusted valve can be detected by **OSCILLATION (UNSTABLE OUTPUT), NOT OBTAINING MAXIMUM FLOW, OR LEAKAGE AT A ZERO SET POINT (LEAK-BY)**.

The following valve adjustment procedure may correct the above conditions.

Equipment needed:

L and M:

1/16" hex wrench

5/16" nut driver

H:

Standard screwdriver

3/8" nut driver

(Quick fix for leak-by). If your unit is experiencing **leak-by**, first confirm that this condition is mechanical in nature rather than electrical by shutting down the power. If leak-by stops (check for downstream flow), the problem is electrical in nature and the instrument may require factory repair. If leak-by continues, the problem is mechanical and may be fixed by an adjustment. Remove the small cover that is on top of the silver solenoid to the right of the rectangular electronic enclosure. (On some 840L-units this may require removing the plastic electronic enclosure to expose the valve coil.) With the power off, apply the appropriate inlet pressure to the controller per the inlet/outlet operating pressures listed on your label and apply a zero setpoint. Loosen the lock nut. Adjust the center adjustment screw slowly clockwise (increasing the spring tension) 1/4 turn at a time until this leak-by subsides. (Putting your finger over the outlet fitting can confirm

the no-leak condition). Now, adjust this screw clockwise one quarter turn past this point, tighten the locknut and replace the cap. Apply power and test the controller for proper operation.

(Quick fix for oscillation). If your unit is experiencing **oscillations** at lower flows, apply power, apply the desired setpoint, and adjust the valve spring adjustment screw $\frac{1}{4}$ turn at a time clockwise (increasing the spring tension – see procedure above) during flow until the symptoms disappear. Adjust $\frac{1}{4}$ turn further and tighten the locknut.

If your unit is experiencing **other symptoms** listed above, you may require this more involved adjustment method. Obtain a voltmeter and prepare to monitor the voltage found on pins 4 to 6 on a D-connector, or D to F on a card-edge connector. Or, if these pins are inaccessible, turn off the power and remove the cable.

1. Remove the screws and/or nuts on the top of the controller electronics cover. Cut the yellow calibration sticker. Remove the silver zero and/or span plugs on the right side of the enclosure or turn the plastic access-hole doors to the vertical position. Pull the cover up and off. Re-connect the cable, apply gas pressure, and apply power to the controller. Connect a voltmeter to the two wires on the back PCA that are routed to the solenoid and set the scale for 30 volts or higher.
2. Determine if this controller has a 15-volt control circuit or a 30-volt control circuit. (Don't confuse this with the setpoint or output signals – this is an internal voltage that energizes the valve coil to raise the valve seat and open the internal orifice). M and H instruments are ALWAYS 30-volt circuits, while L instruments can be either one, based mainly on their flow-rates. Units scaled for below 10 slpm are typically set up for 15 volts while those 10 slpm or over are set up for 30 vdc. (Note: this voltage is typically listed on the calibration certificate in the "Comment" section). If there is any question, contact the factory for clarification.
3. Apply a 100% set point and monitor this valve voltage, allowing at least three minutes for stabilization. The voltage "window" for a 100% setpoint is 13-18 volts for the 30-volt circuit and 9-11 volts for the 15-volt circuit. If the voltage is out of this specification, loosen the lock nut, and adjust the center adjustment screw. Clockwise (downward) will increase the valve voltage, while counterclockwise will decrease it. Adjust

slowly, 1/8 turn at a time and observe until the desired voltage is obtained.

4. Now apply a 5% setpoint signal and confirm that the voltage does not drop below 11 volts on the 30-volt circuit or 6 volts on the 15-volt circuit. Go back and forth between these settings and make sure that the voltages stay within these boundaries. When this voltage “window” is obtained, the symptoms should disappear and the lock nut can be re-tightened.
5. Re-install the electronics cover by powering down the controller, removing the cable, putting the cover back on and replacing the access door plugs. Reconnect the cable and apply the power. A final check for leak-by with a zero set point and proper flow with various control signals should be conducted.

Notes: Adjusting the valve voltage does not change the calibration of the controller. If these adjustments do not obtain the desired operation, contact Sierra directly.

Transducer Calibration



Caution!

It is important that this transducer be calibrated only by qualified personnel.

Calibration of Sierra's flow meters and controllers requires a calibration standard of at least equal accuracy and preferably an order of magnitude of at least four times better than the transducer. Sierra's Cal-Bench Automated Primary Calibration System is the preferred method of calibration and is used at the factory for all calibrations from 10 sccm up to 5600 slpm.

Sierra Instruments maintains a fully-equipped calibration laboratory. All measuring and test equipment used in the calibration of Sierra transducers are traceable to NIST standards. Sierra is ISO-9001 registered and conforms to the requirements of ANSI/NCSL-Z540 and ISO/IEC Guide 25. If the flow body or electronics have been damaged or you simply want to have the transducer recalibrated, contact the factory for return shipping instructions

Chapter 5 Troubleshooting



Warning!

Always remove main power before disassembling the transducer.



Caution!

Only qualified personnel should perform troubleshooting procedures.

This chapter is provided to help locate the cause of a transducer failure. It is not intended to be an all inclusive repair manual. In the case of major repairs, the unit should be returned to the factory for service. Contact Sierra Customer Service for return shipping instructions (page 5-4).

When you suspect that the transducer is not operating correctly, there are a few simple checks that can be made before dismantling the unit:

1. Make certain that there are no leaks in the line.
2. Check that all cables are connected and are in good condition.
3. Verify that the power supply is of the correct polarity and voltage and properly connected to the transducer.
4. For controllers, check for adequate pressure differential across the controller. Check the valve voltage.
5. Double check connector pin outs when replacing another manufacturer's transducer.

After verifying the factors above, follow the troubleshooting procedures outlined on the next page.

Flow Meters and Flow Controllers with Electromagnetic Valves

Problem	Possible Cause	Solution
No output	Clogged sensor	Clean or replace sensor
	PCB defective	Repair or replace PCB
	Inlet filter screen clogged	Clean or replace screen
Unit will not zero	Gas leak	Find and correct leaks
	Application requires high pressure and non-horizontal mounting	Re-zero transducer
	PCB defective	Repair or replace PCB
Controller does not respond to set point	Low or no gas pressure	Set correct gas pressure
	Faulty cable or connector	Correct or replace
	Set point is below 2% of full scale	Increase set point or disable auto shut off circuit
Flow does not match set point	No gas pressure	Set correct gas pressure
	Inlet filter screen clogged	Clean or replace
	Out of adjustment	Adjust R22 balance on 840 models, consult factory for others
Reads full scale with no flow or with valve shut	Defective sensor	Return to factory for replacement
	Gas leak	Find and correct leaks
Out of calibration	Dirty or clogged sensor	Clean or replace sensor
	Change in composition of gas	See K-factory tables
	Gas leak	Find and correct leaks
	PCB defective	Repair or replace PCB
	LFE dirty	Clean LFE
	Inlet filter screen clogged	Clean or replace screen
	Incorrect inlet conditions (high flow and NPT models)	Re-plumb transducer correctly

Flow Controllers with Motor-operated Rotary Valves

Problem	Possible Cause	Solution
Valve “hunts” back and forth continuously	Pressure differential too great	Reduce pressure
	Motor coupling set screws loose	Tighten set screws
	Valve motor failure	Replace motor
Valve rotates continuously	Limit switch out of adjustment or broken	Adjust or replace switch
	Microprocessor failed	Replace microprocessor
Valve does not rotate	Contaminant blocking valve	Remove blockage
	Motor fuse blown	Replace 1 amp fast blow fuse on motor valve board
Flow reading is erratic	Inlet filter screen clogged	Clean or replace screen
Reads full scale with no flow or with valve shut	Defective sensor	Return to factory for replacement
	Q1 shorted	Replace with same type part
	U10 failed	Replace with same type part
Flow does not match set point within specifications	Insufficient pressure differential	Increase pressure or reduce set point

Returning Equipment to the Factory

Factory Calibration—All Models

Sierra Instruments maintains a fully-equipped calibration laboratory. All measuring and test equipment used in the calibration of Sierra transducers are traceable to NIST Standards. Sierra is ISO-9001 registered and conforms to the requirements of ANSI/NCSL-Z540 and ISO/IEC Guide 25.

Instructions for Returning Your Instrument for Service

The following information will help you return your instrument to Sierra Instruments' Factory Service Center and will ensure that your order is processed promptly. We will assign an RMA (Return Materials Authorization) number prior to the unit's return and send you an estimate of charges within 24 hours of receiving your unit. Prices may vary depending on the flow range, type of gas and operating pressure of your unit. To request detailed pricing contact your local Sierra Instruments distributor or contact one of our offices directly. Our expedite fees are: three-day turnaround 25%, two-day turnaround 40%.

Please follow these easy steps to return your instrument for factory service:

1. Obtain a Return Materials Authorization (RMA) number from Sierra Instruments. You may obtain this from the factory by calling (800) 866 0200 between 8:00 a.m. and 5:00 p.m. PST Monday through Friday. You may also obtain this number via e-mail by contacting service@sierrainstruments.com.
2. Once you have obtained an RMA number, complete the form. If you require service beyond calibration, but do not know which service(s) will be required, describe the symptoms as accurately as possible on the RMA form. Submit electronically or by fax to (831) 373-2414.
3. Pack your instrument carefully (bubble wrap or molded foam suggested-NOT PEANUTS) and include a copy of the RMA form (complete with Sierra supplied RMA number) with the unit(s).

Ship the unit(s) to the following address:



Caution!

Always fully neutralize any toxic gas trapped inside the instrument before removing it from the gas line.

RETURN ADDRESS:

**Sierra Instruments, Inc.
Attention: Factory Service Center
5 Harris Court, Building L
Monterey, CA 93940 USA**

CUSTOMER SERVICE AND SUPPORT INFORMATION:

Email Technical Support: service@sierrainstruments.com

Email Sales: sales@sierrainstruments.com

FACTORY USA (recommended):

TOLL FREE: 800-866-0200

PHONE: 831-373-0200

FAX: 831-373-4402

EMAIL: service@sierrainstruments.com

European Sales & Service Center:

PHONE: +31 72 5071400

FAX: +31 72 5071401

EMAIL: service@sierra-instruments.nl

Asia Sales & Service Center:

PHONE: + 86 203435 4870

FAX: +86 203435 4872

Appendix A Conversion Formulas and Gas Tables

Conversion of Flow Rate to Other T and P Conditions

The flow rate of your transducer is referenced to certain “standard” conditions of temperature and pressure. Unless otherwise specified in your order, these standard conditions are 21°C (70°F) and 760 mm of mercury (1 atmosphere). If you wish to convert to other “standard” conditions or to find the “actual” conditions in the pipe where your instrument is installed, use the following relationship:

$$Q_2 = \frac{P_1}{P_2} \frac{T_2}{T_1} Q_1 \quad (1)$$

()₁ = The standard conditions under which your instrument was calibrated,

()₂ = The new standard conditions or the actual temperature and pressure conditions in the pipe,

Q₁ = The gas mass flow rate referenced to the calibrated standard conditions (sccm or slm),

Q₂ = The gas mass flow rate referenced to the new standard or actual conditions (sccm or slm—“S” means “standard,” accm or alm—“A” means “actual”),

P = Absolute pressure (kg/cm₂ or psia), and

T = Absolute temperature (°K or °R) (°K = °C + 273, °R = °F + 460).

Example 1: Changing “Standard” Conditions

If your transducer has a flow rate reading of 10.00 slm and was calibrated at standard conditions of 70°F (21°C) and 1 atmosphere (14.7 psia), and if you wish to convert this reading to standard conditions of 32°F (0°C) and 1 atmosphere, then you would use Equation (1) as follows:

$$Q_2 = \frac{14.7}{14.7} \frac{460 + 32}{460 + 70} (10.0) = 9.28 \text{ slm}$$

The flow rate referenced to 0°C will be approximately 7% lower than when referenced to standard conditions of 21°C.

Example 2: Finding the “Actual” Flow Rate

If the flow rate and calibrated standard conditions are as given in Example 1 and you wish to find the actual flow rate at 100°F and 30 psig, then you would use Equation (1) as follows:

$$Q_2 = \frac{14.7}{14.7 + 30} \cdot \frac{460 + 100}{460 + 70} (10.00) = 3.47 \text{ lm}$$

Calculating For a Single Gas

The following tables provide K-factors and thermodynamic properties of gases commonly used with mass flow meters and controllers. The purpose of these tables is two-fold:

1. Calibrating an “actual” gas with a reference gas. This is particularly useful if the actual gas is not a common gas or if it is toxic, flammable, corrosive, etc.
2. Interpreting the reading of a flow meter or flow controller which has been calibrated with a gas other than the actual gas.

In applying the tables, the following fundamental relationship is used:

$$Q_1/Q_2 = K_1/K_2 \quad (1)$$

Where:

Q = The volumetric flow rate of the gas referenced to standard conditions of 0°C and 760 mm Hg (sccm or slm),

K = The K-factor defined in equation (6),

()₁ = Refers to the “actual” gas, and

()₂ = Refers to the “reference” gas.

The K-factor is derived from the first law of thermodynamics applied to the sensor tube, as described in Chapter 1:

$$H = \frac{\dot{m}C_p\Delta T}{N} \quad (2)$$

Where:

H = The constant amount of heat applied to the sensor tube,

\dot{m} = The mass flow rate of the gas (gm/min)

C_p = The coefficient of specific heat of the gas (Cal/gm);
 C_p is given in the Table (at 0°C),

ΔT = The temperature difference between the downstream and upstream coils, and

N = A correction factor for the molecular structure of the gas given by the following table:

Number of Atoms in the Gas Molecule	N
Monatomic	1.040
Diatomic	1.000
Triatomic	0.941
Polyatomic	0.880

The mass flow rate, \dot{m} , can also be written as:

$$\dot{m} = \rho Q \quad (3)$$

Where:

ρ = The gas mass density at standard conditions (g/l); ρ is given in the tables (at 0°C, 760 mm Hg).

Furthermore, the temperature difference, ΔT , is proportional to the output voltage, E , of the mass flow meter, or

$$\Delta T = aE \quad (4)$$

where:

a = A constant.

If we combine equations (3) and (4), insert them into equation (2), and solve for Q , we get

$$Q = (bN/\rho C_p) \quad (5)$$

where:

$b = H/aE = a$ constant if the output voltage is constant.

For our purposes, we want the ratio of the flow rate, Q_1 , for an actual gas to the flow rate of a reference gas, Q_2 , which will produce the same output voltage in a particular mass flow meter or controller. We get this by combining equations (1) and (5):

$$Q_1/Q_2 = K_1/K_2 = (N_1/\rho_1 C_{p1})/(N_2/\rho_2 C_{p2}) \quad (6)$$

Please note that the constant b cancels out. Equation (6) is the fundamental relationship used in the accompanying tables. For convenience, the tables give “relative” K-factors, which are the ratios K_1/K_2 , instead of the K-factors themselves. In the tables, the relative K-factor is

K_{actual}/KN_2 where the reference gas is the commonly used gas, nitrogen (N_2). The remaining columns give C_p and ρ , enabling you to calculate K_1/K_2 directly using Equation (6). In some instances, K_1/K_2 from the tables may be different from that which you calculate directly. The value from the tables is preferred because in many cases it was obtained by experiment. Sierra calibrates every transducer with primary standards using the actual gas or a molecular equivalent reference gas. The calibration certificate accompanying the transducer cites the reference gas used.

Example 1:

A transducer is calibrated for nitrogen (N_2), and the flow rate is 1000 sccm for a 5.000 VDC output signal. The flow rate for carbon dioxide at a 5.000 VDC output is:

$$Q_{CO_2}/Q_{N_2} = K_{CO_2}/K_{N_2}, \text{ or}$$

$$Q_{CO_2} = (0.74/1.000)1000 = 740 \text{ sccm}$$

Example 2:

A transducer is calibrated for hydrogen (H_2), and the flow rate is 100 sccm for a 5.000 VDC output signal. The flow rate for nitrous oxide (N_2O) is found as follows:

$$Q_{N_2O}/Q_{H_2} = K_{N_2O}/K_{H_2}, \text{ or}$$

$$Q_{N_2O} = (0.71/1.01) 100 = 70.3 \text{ sccm}$$

Note that the K-factors relative to nitrogen must be used in each case.

Example 3:

We want a transducer to be calibrated for use with dichlorosilane (SiH_2Cl_2) at a 100 sccm full scale flow. We wish to use the preferred reference gas Freon-14 (CF_4). What flow of CF_4 must we generate to do the calibration?

$$Q_{SiH_2Cl_2}/Q_{CF_4} = K_{SiH_2Cl_2}/K_{CF_4}$$

$$100/Q_{CF_4} = 0.869$$

$$Q_{CF_4} = 100/0.869 = 115 \text{ sccm}$$

Calculating Dual Gas Mixtures

Equation (6) is used for gas mixtures, but we must calculate $N/\rho C_p$ for the mixture. The equivalent values of ρ , C_p , and N for a dual gas mixture are given as follows:

The equivalent gas density is:

$$\rho = (\dot{m}_1 / \dot{m}_T) \rho_1 + (\dot{m}_2 / \dot{m}_T) \rho_2$$

Where:

$$\dot{m}_T = \dot{m}_1 + \dot{m}_2 = \text{Total mass flow rate (gm/min),}$$

()₁ = Refers to gas #1, and

()₂ = Refers to gas #2

The equivalent specific heat is:

$$C_p = F_1 C_{p1} + F_2 C_{p2}$$

Where:

$$F_1 = (\dot{m}_1 \rho_1) / (\dot{m}_T \rho)$$
 and

$$F_2 = (\dot{m}_2 \rho_2) / (\dot{m}_T \rho)$$

The equivalent value of N is:

$$N = (\dot{m}_1 / \dot{m}_T) N_1 + (\dot{m}_2 / \dot{m}_T) N_2$$

The equivalency relationships for ρ , C_p , and N for mixtures of more than two gases have a form similar to the dual-gas relationship given above.

IMPORTANT NOTE ABOUT K-FACTORS:

Please note that if you have a transducer calibrated for a gas such as methane and wish to use the K-factors to measure a gas such as air, that the inaccuracy of the measurement can range from ± 5 to 10%. The use of K-factors is, at best, only a rough approximation and should not be used in applications that require a better than ± 5 to 10% accuracy.

It should also be noted that certain gases, in similar “families,” will work exceptionally well with K-factors; however, those instances are only true when similar thermal properties of the gas are present.

Gas Tables and -K factors

Actual Gas	Chemical Symbol	K-factor Relative N2	Cp (Cal/g)	Density (g/l) @ 0°C	Elastomer	
					O-ring*	Valve Seat
Acetylene	C ₂ H ₂	.58	.4036	1.162		
Air		1.00	.240	1.293		
Allene (Propadiene)	C ₃ H ₄	.43	.352	1.787		KR
Ammonia	NH ₃	.73	.492	.760	NEO	NEO
Argon	Ar	1.45	.1244	1.782		
Arsine	AsH ₃	.67	.1167	3.478		KR
Boron Trichloride	BCl ₃	.41	.1279	5.227	KR	KR
Boron Trifluoride	BF ₃	.51	.1778	3.025		KR
Bromine	Br ₂	.81	.0539	7.130		
Boron Tribromide	Br ₃	.38	.0647	11.18		KR
Bromine Pentafluoride	BrF ₅	.26	.1369	7.803		KR
Bromine Trifluoride	BrF ₃	.38	.1161	6.108		KR
Bromotrifluoromethane (Freon -13 B1)	CBrF ₃	.37	.1113	6.644		
1,3-Butadiene	C ₄ H ₆	.32	.3514	2.413		
Butane	C ₄ H ₁₀	.26	.4007	2.593		
1-Butane	C ₄ H ₈	.30	.3648	2.503	NEO	KR
2-Butane	C ₄ H ₈ CIS	.324	.336	2.503	NEO	KR
2-Butane	C ₄ H ₈ TRANS	.291	.374	2.503		
Carbon Dioxide	CO ₂	.74	.2016	1.964		
Carbon Disulfide	CS ₂	.60	.1428	3.397		
Carbon Monoxide	CO	1.00	.2488	1.250		
Carbon Tetrachloride	CCl ₄	.31	.1655	6.860		KR
Carbon Tetrafluoride (Freon -14)	CF ₄	.42	.1654	3.926		
Carbonyl Fluoride	COF ₂	.54	.1710	2.945		
Carbonyl Sulfide	COS	.66	.1651	2.680		
Chlorine	CL ₂	.86	.114	3.163		KR
Chlorine Trifluoride	ClF ₃	.40	.1650	4.125		KR
Chlorodifluoromethane (Freon -22)	CHClF ₂	.46	.1544	3.858		KR
Chloroform	CHCl ₃	.39	.1309	5.326		KR
Chloropentafluoroethane (Freon -115)	C ₂ ClF ₅	.24	.164	6.892		KR
Chlorotrifluoromethane (Freon -13)	CClF ₃	.38	.153	4.660		KR
Cyanogen	C ₂ N ₂	.61	.2613	2.322		KR
Cyanogen Chloride	ClCN	.61	.1739	2.742		
Cyclopropane	C ₃ H ₅	.46	.3177	1.877		KR
Deuterium	D ₂	1.00	.1722	1.799		
Diborane	B ₂ H ₆	.44	.508	1.235		KR
Dibromodifluoromethane	CBr ₂ F ₂	.19	.15	9.362		KR
Dibromomethane		.47	.075	7.76		KR
Dichlorodifluoromethane (Freon -12)	CCl ₂ F ₂	.35	.1432	5.395		KR
Dichlorofluoromethane (Freon -21)	CHCl ₂ F	.42	.140	4.952		KR

Actual Gas	Chemical Symbol	K-factor Relative N2	Cp (Cal/g)	Density (g/l) @ 0°C	Elastomer O-ring* Valve Seat	
Dichloromethylsilane	(CH ₃) ₂ SiCl ₂	.25	.1882	5.758		KR
Dichlorosilane	SiH ₂ Cl ₂	.40	.150	4.506		KR
Dichlorotetrafluoroethane (Freon-114)	C ₂ Cl ₂ F ₄	.22	.1604	7.626		KR
1,1-Difluoroethylene (Freon-1132A)	C ₂ H ₂ F ₂	.43	.224	2.857		KR
Dimethylamine	(CH ₃) ₂ NH	.37	.366	2.011		KR
Dimethyl Ether	(CH ₃) ₂ O	.39	.3414	2.055		KR
2,2-Dimethylpropane	C ₃ H ₁₂	.22	.3914	3.219		KR
Ethane	C ₂ H ₆	.50	.4097	1.342		
Ethanol	C ₂ H ₆ O	.39	.3395	2.055		KR
EthylAcetylene	C ₄ H ₆	.32	.3513	2.413		KR
Ethyl Chloride	C ₂ H ₅ Cl	.39	.244	2.879		KR
Ethylene	C ₂ H ₄	.60	~.358	1.251		
Ethylene Oxide	C ₂ H ₄ O	.52	.268	1.965	KR	KR
Fluorine	F ₂	.980	.1873	1.695		KR
Fluoroform (Freon-23)	CHF ₃	.50	.176	3.127		KR
Freon-11	CCl ₃ F	.33	.1357	6.129		KR
Freon-12	CCl ₂ F ₂	.35	.1432	5.395		KR
Freon-13	CCIF ₃	.38	.153	4.660		KR
Freon-13	B1 CFrF ₃	.37	.1113	6.644		KR
Freon-14	CF ₄	.42	.1654	3.926		
Freon-21	CHCl ₂ F	.42	.140	4.952		KR
Freon-22	CHClF ₂	.46	.1544	3.858		KR
Freon-113	CCl ₂ FCClF ₂	.20	.161	8.360		KR
Freon-114	C ₂ Cl ₂ F ₄	.22	.160	7.626		KR
Freon-115	C ₂ ClF ₅	.24	.164	6.892		KR
Freon-C318	C ₄ F ₈	.17	.185	8.397	NEO	NEO
Germane	GeH ₄	.57	.1404	3.418		
Germanium Tetrachloride	GeCl ₄	.27	.1071	9.565		KR
Helium	He	1.454	1.241	.1786		
Hexafluoroethane (Freon-116)	C ₂ F ₆	.24	.1834	6.157		KR
Hexane	C ₆ H ₁₄	.18	.3968	3.845		KR
Hydrogen	H ₂	1.01	3.419	.0899		
Hydrogen Bromide	HBr	1.000	.0861	3.610		KR
Hydrogen Chloride	HCl	1.000	.1912	1.627	KR	KR
Hydrogen Cyanide	HCN	1.070	.3171	1.206		KR
Hydrogen Fluoride	HF	1.000	.3479	.893	KR	KR
Hydrogen Iodide	HI	1.000	.0545	5.707		KR
Hydrogen Selenide	H ₂ Se	.79	.1025	3.613		KR
Hydrogen Sulfide	H ₂ S	.80	.2397	1.520	KR	KR
Iodine Pentafluoride	IF ₅	.25	.1108	9.90		KR
Isobutane	CH(CH ₃) ₃	.27	.3872	2.593		KR
Isobutylene	C ₄ H ₈	.29	.3701	2.503		KR
Krypton	Kr	1.453	.0593	3.739		
Methane	CH ₄	.72	.5328	.715		
Methanol	CH ₃ OH	.58	.3274	1.429		
Methyl Acetylene	C ₃ H ₄	.43	.3547	1.787		KR
Methyl Bromide	CH ₃ Br	.58	.63	.1106	4.236	
Methyl Chloride	CH ₃ Cl	.1926	2.253			KR
Methyl Fluoride	CH ₃ F	.68	.3221	1.518		KR

Actual Gas	Chemical Symbol	K-factor Relative N2	Cp (Cal/g)	Density (g/l) @ 0°C	Elastomer O-ring* Valve Seat	
Methyl Mercaptan	CH ₃ SH	.52	.2459	2.146		KR
Methyl Trichlorosilane	(CH ₃) ₃ SiCl ₃	.25	.164	6.669		KR
Molybdenum Hexafluoride	MoF ₆	.21	.1373	9.366		KR
Monoethylamine	C ₂ H ₅ NH ₂	.35	.387	2.011		KR
Monomethylamine	CH ₃ NH ₂	.51	.4343	1.386		KR
Neon	NE	1.46	.245	.900		
Nitric Oxide	NO	.990	.2328	1.339		
Nitrogen	N ₂	1.000	.2485	1.25		
Nitrogen Dioxide	NO ₂	.74	.1933	2.052	KR	KR
Nitrogen Trifluoride	NF ₃	.48	.1797	3.168		KR
Nitrosyl Chloride	NOCl	.61	.1632	2.920		KR
Nitrous Oxide	N ₂ O	.71	.2088	1.964		
Octafluorocyclobutane (Freon-C318)	C ₄ F ₆	.17	.185	8.397		KR
Oxygen Difluoride	OF ₂	.63	.1917	2.406		
Oxygen	O ₂	1.000	.2193	1.427		
Ozone	O ₃	.446	.3	2.144		
Pentaborane	B ₅ H ₉	.26	.38	2.816		KR
Pentane	C ₅ H ₁₂	.21	.398	3.219		KR
Perchloryl Fluoride	ClO ₃ F	.39	.1514	4.571		KR
Perfluoropropane	C ₃ F ₈	.174	.197	8.388		KR
Phosgene	COCl ₂	.44	.1394	4.418		KR
Phosphine	PH ₃	.76	.2374	1.517		KR
Phosphorous Oxychloride	POCl ₃	.36	.1324	6.843		KR
Phosphorous Pentafluoride	PF ₅	.30	.1610	5.620		KR
Phosphorous Trichloride	PCl ₃	.30	.1250	6.127		KR
Propane	C ₃ H ₈	.36	.3885	1.967		KR
Propylene	C ₃ H ₆	.41	.3541	1.877		
Silane	SiH ₄	.60	.3189	1.433		KR
Silicon Tetrachloride	SiCl ₄	.28	.1270	7.580		KR
Silicon Tetrafluoride	SiF ₄	.35	.1691	4.643		KR
Sulfur Dioxide	SO ₂	.69	.1488	2.858		KR
Sulfur Hexafluoride	SF ₆	.26	.1592	6.516		
Sulfuryl Fluoride	SO ₂ F ₂	.39	.1543	4.562		KR
Teos		.090			KR	KR
Tetrafluorahydrazine	N ₂ F ₄	.32	.182	4.64		KR
Trichlorofluoromethane (Freon-11)	CCl ₃ F	.33	.1357	6.129		KR
Trichlorosilane	SiHCl ₃	.33	.1380	6.043		KR
1,1,2-Trichloro-1,2,2 Trifluoroethane (Freon-113)	CCl ₂ FCCLF ₂	.20	.161	8.360		KR
Triisobutyl Aluminum	(C ₄ H ₉) ₃ Al	.061	.508	8.848		KR
Titanium Tetrachloride	TiCl ₄	.27	.120	8.465		KR
Trichloro Ethylene	C ₂ HCl ₃	.32	.163	5.95		KR
Trimethylamine	(CH ₃) ₃ N	.28	.3710	2.639		KR
Tungsten Hexafluoride	WF ₆	.25	.0810	13.28	KR	Teflon
Uranium Hexafluoride	UF ₆	.20	.0888	15.70		KR
Vinyl Bromide	CH ₂ CHBr	.46	.1241	4.772		KR
Vinyl Chloride	CH ₂ CHCl	.48	.12054	2.788		KR
Xenon	Xe	1.44	.0378	5.858		

Appendix B Product Specifications

Operating Specifications

Gases	All clean gases; specify when ordering
Mass Flow Rates	0 to 10 sccm to 0 to 5600 slpm; flow ranges specified are for an equivalent flow of nitrogen at 760 mm Hg and 21°C (70°F); other ranges in other units are available (e.g. scfh or nm ³ /h)
Gas Pressure	500 psig (34 barg) maximum; 30 psig (2 barg) optimum
Gas, Ambient Temperature	32° to 176°F (0 to 80°C); above 122°F(50°C) requires HT or RT option.
Leak Integrity	5 X 10 ⁻⁹ atm cc/sec of helium maximum
Pressure Drop	830/860M (low)0.08 psi (0.006 bar) differential max; 15 slpm: 1.5 psi (0.20 bar) differential max 830/860M (med)0.08 psi (0.006 bar) differential max; 100 slpm: 1.5 psi (0.20 bar) differential max 830/860M (high).....100 to 199 slpm: 2 psi (0.15 bar) differential max; 200 to 500 slpm: 8.5 psi (0.58 bar) differential max 830 NPT 1.5 psi (0.20 bar) differential maximum
Differential Pressure Requirements30 psi (2.1 bar) differential optimum for all 840/860C (low)5 to 50 psi (1.0 to 3.4 bar) differential standard; 30 psi (2.1 bar) differential optimum; lower or higher (100 psi maximum) ΔP available on special order 840/860C (med).....15 to 50 slpm: 5 to 50 psi (1.0 to 3.4 bar) differential; 51 to 100 slpm: 15 to 50 psi (1.0 to 2.8 bar) differential standard 840/860C (high)100 to 199 slpm: 10 to 50 psi (1.0 to 3.4 bar) differential; 200 to 500 slpm: 10 to 40 psi (0.7 to 2.8 bar) differential standard 840 (NPT) 10 to 50 psi (0.7 to 3.4 bar) differential standard;
Power Requirements	830/860M+ 15 VDC @ 80 mA, 1.2 watts and -15 VDC @ 10 mA, 0.15 watts 840/860C (low)+15 VDC @ 130 mA, 2.0 watts and -15 VDC @ 200 mA, 2.6 watts 840/860C (med).....+15 VDC @ 400 mA, 6.0 watts and -15 VDC @ 300 mA, 4.5 watts 840/860C (high)+15 VDC @ 1.13 A, 17 watts and -15 VDC @ 1.06 A 16 watts 840 (NPT)+15 VDC @ 230 mA, 3.5 watts and -15 VDC @ 170 mA, 2.6 watts

Control Range	840/860 (all sizes).. 2 to 100% of full scale; valve shuts between 1 to 2.5% of full scale 840 (NPT) 10 to 100% of full scale
Command Signal	0-5 VDC, 20 megaohms minimum input impedance 4-20 mA, 250 Ohms maximum input impedance, optional RS-485 digital signal standard on Model 860C
Output Signal	Linear 0-5 VDC, 1000 Ohms minimum load resistance Linear 4-20 mA, 500 Ohms maximum loop resistance

Performance Specifications

Accuracy	±1% of full scale including linearity over 15 to 25°C and 10 to 60 psia (0.7 to 4 bara); ±2% of full scale including linearity over 0 to 50°C and 5 to 50 psia (0.3 to 10 bara); ±1% of full scale accuracy at a specific temperature and pressure is available with special calibration; For the models 840 (NPT), the accuracies above are 1.5%, ±3%, and ±1.5%, respectively
Repeatability	±0.15% of full scale ±0.5% of full scale for 840 (NPT)
Temperature Coefficient	0.08% of full scale per °F (0.15% of full scale per °C), or better
Pressure Coefficient	0.01% of full scale per psi (0.15% of full scale per bar), or better
Response Time	830 (all) 300 ms time constant; 2 seconds (typical) to within ±2% of set point over 20 to 100% of full scale 840 (low, med) 300 ms time constant; 2 seconds (typical) to within ±2% of set point over 20 to 100% of full scale 840 (high) 600 ms time constant; 4 seconds (typical) to within ±2% of set point over 20 to 100% of full scale 840 (NPT) 800 ms time constant; 4 seconds (typical) to within ±5% of set point over 20 to 100% of full scale 860 (all) 0.6 to 1 second to within ±2% of set point over 20 to 100% of full scale

Physical Specifications

Wetted Materials	830 (all)316 stainless steel, Viton® O-rings standard; Neoprene® and Kal-Rez® optional 840/860 (low, med, high)316 stainless steel, 430F stainless steel, Viton O-rings and valve seat standard; Neoprene and Kal-Rez optional PFA Teflon valve seat available 840 (NPT) 316 stainless steel, Teflon® valve set, Viton O-rings
Control Valve Type	840/860C (low, med, high)Electromagnetic 840 (NPT)Rotary plug valve

Transducer Mounting Dimensions

All dimensions are inches, millimeters are in parentheses. Certified drawings are available on request. Shaded portion of dimensional drawings indicates controller models.

Low Flow Body

Flow Range, 0 –10 sccm to 0 –15 slpm			
Process Tubing	.25 (6.4)		
.562-18 Thread (on Flow Body)			
Fitting Type	Compression .125 or .25	VCO (male) .25	VCR (male) .25
Dim. L	4.84 or 5.0 (122.9 or 127.0)	4.60 (116.8)	4.90 (124.5)
Metric fittings are available, consult factory			

Model 830/840—Side View

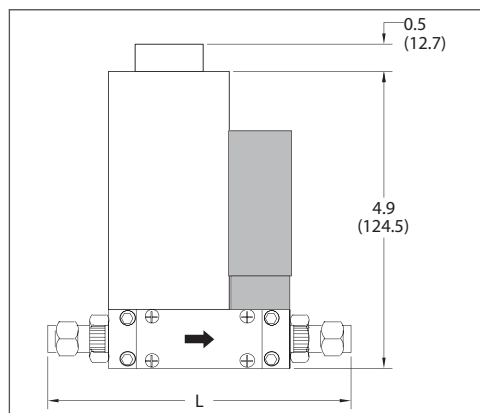

Model 830/840—Bottom View

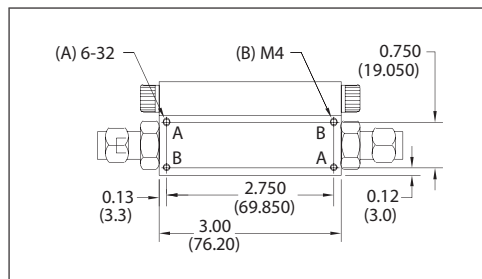

Model 830/840—Outlet View

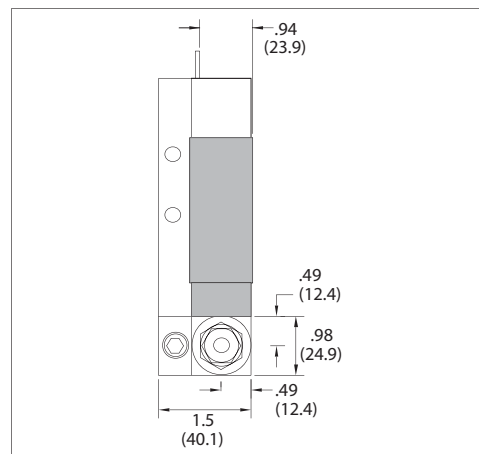

Medium Flow Body

Flow Range, slpm				
	0–15	0–30	0–50, 100	0–100
Process Tubing	.25 or .375 (6.4 or 9.5)	.25 or .375 (6.4 or 9.5)	.25 or .375 (6.4 or 9.5)	.375 (9.5)

.562-18 Thread (on Flow Body)			
Fitting Type	Compression .25 or .375	VCO (male) .25 or .375	VCR (male) .25 or .375
Dim. L	6.27 or 6.39 (159.3 or 162.3)	5.81 or 6.25 (147.6 or 158.8)	6.13 or 6.43 (155.7 or 163.3)

Metric fittings are available, consult factory

Model 830/840—Side View

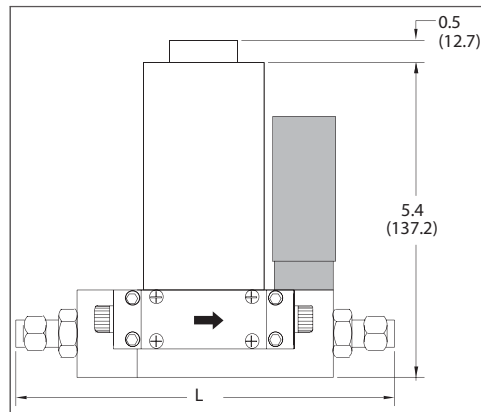

Model 830/840—Bottom View

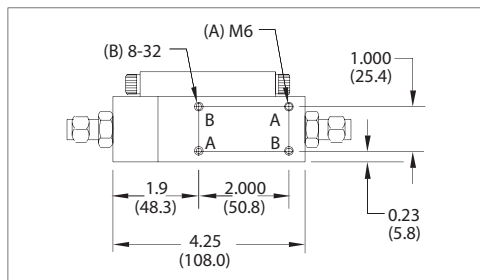

Model 830/840—Outlet View

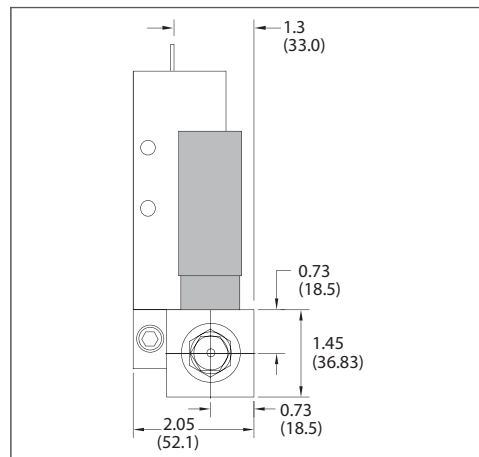

High Flow Body

Flow Range, slpm					
	0-100	0-200	0-300	0-400	0-500
Process Tubing	.375 or .50 (9.5 or 12.7)	.375 or .50 (9.5 or 12.7)	.50 (12.7)	.50 (12.7)	.50 (12.7)

.75 -16 Thread (on Flow Body)			
Fitting Type	Compression .375 or .50	VCO (male) .375	VCR (male) .375
Dim. L 830	11.90 or 12.10 (302.3 or 307.3)	11.80 (299.7)	12.19 (309.6)
Dim. L2 840	14.10 or 14.30 (358.1 or 363.2)	14.00 (355.6)	14.40 (365.8)

Metric fittings are available, consult factory

Model 830/840—Side View

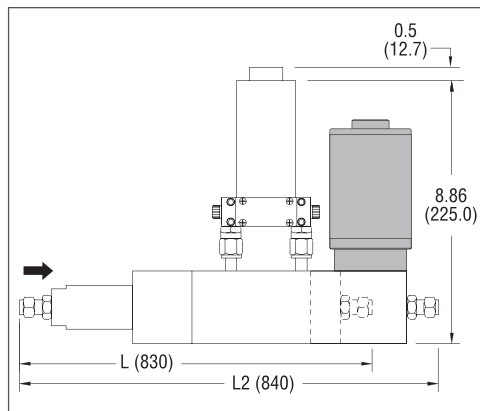

Model 830/840—Bottom View

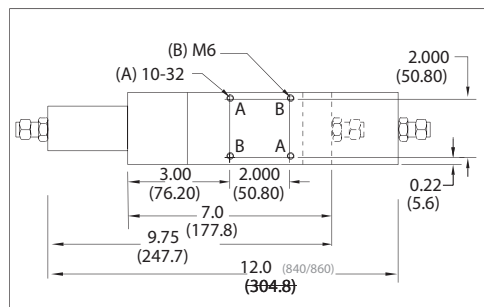

Model 830/840—Outlet View

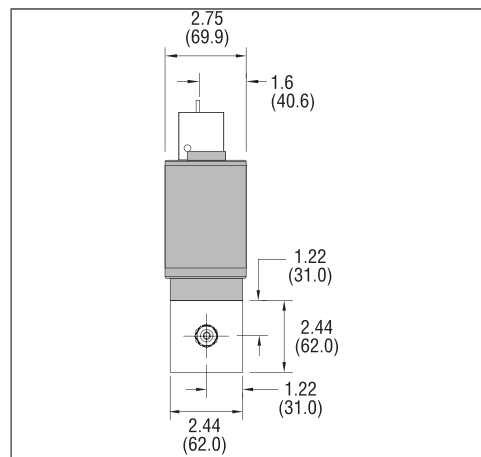

NPT Flow Body

830 Flow Range, SCFM			
	0-50	0-100	0-200
Inlet FNPT	1-inch	1.5-inch	2-inch
Outlet FNPT	1-inch	1.5-inch	2-inch
Dim. D	4.95 (125.7)	5.95 (151.1)	7.95 (201.9)
Dim. H	10.72 (272.3)	11.72 (297.7)	13.78 (350.0)
Dim. H2	8.25 (209.6)	8.75 (222.3)	9.81 (249.2)
Dim. L	10.10 (256.5)	12.10 (307.3)	16.10 (408.9)
inches (mm)			

Model 830—Side View

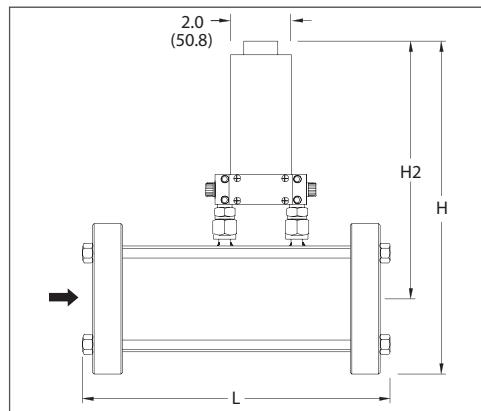

Model 830—Bottom View

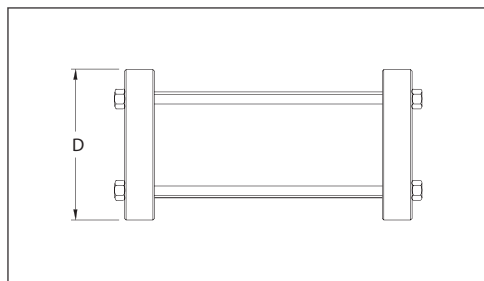

Model 830—Outlet View

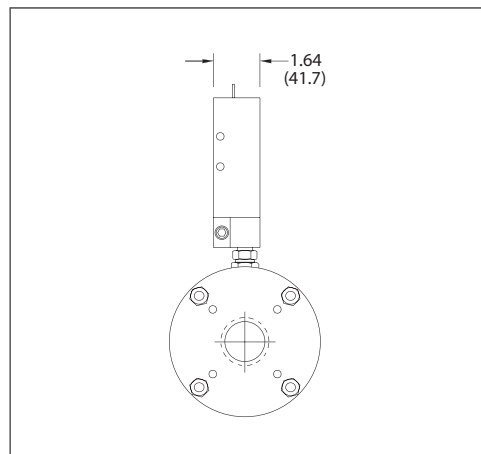

NPT Flow Body

840 Flow Range, SCFM			
	0-50	0-100	0-200
Inlet FNPT	1-inch	1.5-inch	2-inch
Outlet FNPT	3/4-inch	3/4-inch	1.5-inch
Dim. A	2.92 (74.2)	4.30 (109.2)	6.64 (168.7)
Dim. B	1.0 (25.4)	1.88 (47.8)	2.87 (72.9)
Dim. C	2.25 (57.2)	1.37 (34.8)	.38 (9.7)
Dim. D	4.95 (125.7)	5.95 (151.1)	7.95 (201.9)
Dim. H	10.72 (272.3)	11.72 (297.7)	13.78 (350.0)
Dim. H2	8.25 (209.6)	8.75 (222.3)	9.81 (249.2)
Dim. L	10.10 (256.5)	12.10 (307.3)	16.10 (408.9)
inches (mm)			

Model 840—Side View

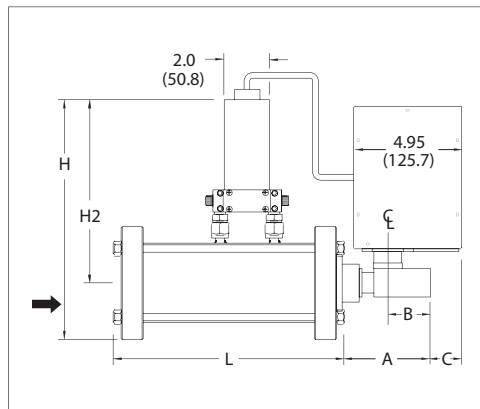

Model 840—Bottom View

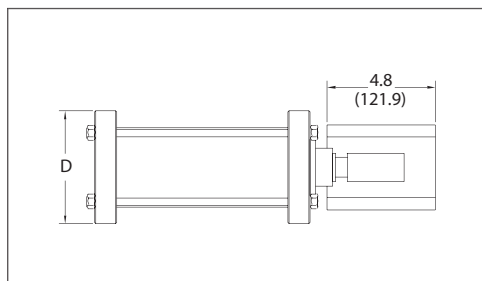

Model 840—Outlet View

