

Max-Trak Series 180

Mass Flow Meters & Controllers
Instruction Manual



IM-180 Series
Rev. B.8, June 2010



GLOBAL SUPPORT LOCATIONS: WE ARE HERE TO HELP!

CORPORATE HEADQUARTERS

5 Harris Court, Building L Monterey, CA 93940
Phone (831) 373-0200 (800) 866-0200 Fax (831) 373-4402
www.sierrainstruments.com

EUROPE HEADQUARTERS

Bijlmansweid 2 1934RE Egmond aan den Hoef
The Netherlands
Phone +31 72 5071400 Fax +31 72 5071401

ASIA HEADQUARTERS

Rm. 618, Tomson Centre, Bldg A, 188 Zhang Yang Road
Pu Dong New District, Shanghai, P.R. China
Phone: + 8621 5879 8521 Fax: +8621 5879 8586

IMPORTANT CUSTOMER NOTICE: OXYGEN SERVICE

Sierra Instruments, Inc. is not liable for any damage or personal injury, whatsoever, resulting from the use of Sierra Instruments standard mass flow meters or controllers for oxygen gas. You are responsible for determining if this mass flow meter or controller is appropriate for your oxygen application. You are responsible for cleaning the mass flow meter or controller to the degree required for your oxygen flow application.

© COPYRIGHT SIERRA INSTRUMENTS 2010

No part of this publication may be copied or distributed, transmitted, transcribed, stored in a retrieval system, or translated into any human or computer language, in any form or by any means, electronic, mechanical, manual, or otherwise, or disclosed to third parties without the express written permission of Sierra Instruments. The information contained in this manual is subject to change without notice.

TRADEMARKS

Smart-Trak[®] 100 Series and Dial-A-Gas[™] is a Registered Trademark of Sierra Instruments, Inc. Other product and company names listed in this manual are trademarks or trade names of their respective manufacturers.

TABLE OF CONTENTS

Chapter 1 Introduction

Introduction	1-1
Using this Manual	1-1
Safety Information.....	1-2
Receipt of System Components	1-2
Definitions Used in This Manual	1-3
The Smart-Trak Flow Sensing Principle.....	1-4

Chapter 2 Installation

Before You Begin Installation.....	2-1
Smart-Trak Data Labels	2-1
Pre-Installation Checklist	2-2
Installing the Instrument-Plumbing.....	2-3
Compression Fittings.....	2-3
VCO Fittings	2-4
VCR Fittings.....	2-4
1/4-inch Female NPT Fittings	2-4
Installing the Instrument-Mechanical Mounting.....	2-5
Installing the Instrument-Electrical Connections.....	2-5
Terminal Strip PIN assignments.....	2-7
Cable Wire Color Codes.....	2-7
Power Supply Requirements	2-8
Basic Analog Installation	2-8
Configuring the Instrument	2-9
RS-232 Wiring	2-10

Chapter 3 Analog Operation

Introduction	3-1
Analog Operation, Mass Flow Meters	3-1
Analog Operation, Mass Flow Controllers	3-2
Max-Trak Features	3-3
Setpoint Adjustment.....	3-3
Changing the Output or Setpoint Signals	3-3
Over-Range Condition	3-4
Manual Valve Override-Valve Close.....	3-4
Manual Valve Override-Valve Purge.....	3-4
Purge Safety Notes	3-5

Chapter 4 RS-232 Operation with Smart-Trak Software

Introduction	4-1
Summary of Max-Trak Features	4-2
Power Up Your Instrument	4-3
Power Up Your Computer.....	4-3
Loading the Smart-Trak Software.....	4-4
Connecting Smart-Trak to your Computer.....	4-5
Running the Smart-Trak Software	4-7
Using the Smart-Trak Software.....	4-10
Upper Section of Software Window	4-10
Password Section.....	4-11
Lower Section of Software Window	4-12
Change Setpoint Value.....	4-12
Change Valve Operation (Close, Purge).....	4-13
Change Gas (Dial-A-Gas™)	4-13
Change Units	4-14
Change Setpoint Source	4-14
Change Output Signal	4-15
Change Full Scale.....	4-15
Change Password (Lost Passwords).....	4-16
Lost Password.....	4-17
Other Useful Features.....	4-17
Comm Port.....	4-18
Read Controller Parameters.....	4-18

Chapter 5 Configuration using Remote Pilot Module

Introduction to the Pilot Module	5-1
Pilot Module Features and Capabilities	5-2
Pilot Module Menus and User Interface	5-4
Map of the User Interface.....	5-5
Upper Screens (Display)	5-6
Mass Flow Screen	5-6
Setpoint Screen.....	5-6
Valve Position Screen	5-7
Full Scale Screen.....	5-7
Password Screen.....	5-8
Lost Password.....	5-9
Lower Level Screens (Changing Configuration)	5-10
Change Setpoint Value Screen.....	5-10

Change Units Screen	5-13
Change Gas (Dial-A-Gas™) Screen	5-14
Change Valve Operation (Close, Purge) Screen	5-15
Change Setpoint Source Screen	5-16
Change Output Signals Screen	5-18
Change Full Scale Screen.....	5-19
Change Password Screen.....	5-20
Lost Password.....	5-21
Maintenance Functions.....	5-22

Chapter 6 Technical Support and Service

Technical Support.....	6-1
Sierra Website	6-2
Returning Equipment to the Factory.....	6-3

Appendix A Gas Tables

Pre-programmed gas list-Dial-A-Gas.....	A-1
K-Factor Calculations	A-1
Gas Tables with K-factors.....	A-2

Appendix B Product Specifications

Performance Specifications.....	B-1
Operating Specifications	B-1
Physical Specifications	B-4
Optional Accessories.....	B-5

Appendix C Flow Chart for Pilot Module User Interface

Appendix D HD DB-15 PIN Configuration

Appendix E Dimensions and Mounting

CHAPTER 1: INTRODUCTION

Welcome to the future of gas flow measurement!

The Sierra Instruments' Max-Trak Series 180 is an innovation from Sierra, a company that has designed and manufactured gas mass flow measurement instruments since the early 1970's. This manual is your guide to Max-Trak, our water-resistant series of mass flow meters and controllers. The Series 180 Max-Trak is the rugged industrial version of Sierra's popular Series 100 Smart-Trak and the two products share many innovative features. Visit the Sierra Instruments website www.sierrainstruments.com any time for more information about both of these products.

The Max-Trak instruments offer a variety of features for ease of operation. Among these features:

- ✓ **Dial-A-Gas:** allows a user to change from among 10 gases while maintaining accuracy.
- ✓ **Digital Electronics:** maximum performance with minimum noise plus exceptional tuning capability.
- ✓ Choice of **4 Analog Communications Options and RS-232** with every Max-Trak instrument.
- ✓ **Flexible Design** with many functions that can be re-configured on-site by the user.
- ✓ **Choice of Electric Connections** including our water-tight plug-and-play option
- ✓ **The Optional Pilot Module:** control electronics that offers a large LCD display with convenient instrument configuration and trouble-shooting options at your fingertips.
- ✓ **And many more...visit www.sierrainstruments.com**

Using This Manual

This manual is organized into six chapters:

- **Chapter 1:** Introduction and Theory of Operation.
- **Chapter 2:** Installation, Plumbing & Wiring instructions.
- **Chapter 3:** Analog Operation.
- **Chapter 4:** Digital Operation with the Optional Pilot Module.
- **Chapter 5:** Digital Operation with RS-232 & Max-Trak Software.
- **Chapter 6:** Technical Support and Service.

There are also 5 Appendices:

- **Appendix A:** Max-Trak Pre-Programmed gases, Conversion Formula and Gas Tables.
- **Appendix B:** Product Specifications, useful Optional Parts & Accessories
- **Appendix C:** Flowchart for the Pilot Module.
- **Appendix D:** PIN Configuration of the mini-D connector
- **Appendix E:** Dimensional Drawings & Mounting Instructions.

Throughout this manual, we use the word *instrument* as a generic term to represent all models of Sierra Instruments' **Max-Trak Series 180** mass flow meters and controllers.

SAFETY INFORMATION

Caution and warning statements are used throughout this book to draw your attention to important information.



Warning!

This statement appears with information that is important to protect people and equipment from damage. Pay very close attention to all warnings that apply to your application.



Caution!

This statement appears with information that is important for protecting your equipment and performance. Read and follow all cautions that apply to your application.

RECEIPT OF YOUR INSTRUMENT

When receiving the instrument, carefully check the outside packing carton for damage that may have incurred during shipment. If the carton is damaged, notify the local carrier and submit a report to the factory or distributor. Remove the packing slip and check that all ordered components are present and match your specifications (as ordered). Make sure any spare parts or accessories are not discarded with the packing material. Do not return any equipment

to the factory without first contacting one of Sierra's Technical Support Centers:

Email Customer Service: service@sierrainstruments.com

USA (Headquarters) Customer Service:

TOLL FREE: 800-866-0200

PHONE: 831-373-0200

FAX: 831-373-4402

EMAIL: service@sierrainstruments.com

European Customer Service:

PHONE: +31 72 5071400

FAX: +31 72 5071401

EMAIL: service@sierra-instruments.nl

Asia Customer Service:

PHONE: + 8621 5879 8521

FAX: +8621 5879 8586

EMAIL: www.sierra-asia.com

DEFINITIONS USED IN THIS MANUAL

The following terms are used frequently in this manual. They are presented here with their definitions for your information.

Setpoint—The command or control signal supplied to a flow controller is called its setpoint. The controller will maintain the flow at this value.

Full scale—The highest flow that an instrument will meter within its specified accuracy. It is often possible for an instrument to measure a flow beyond its full scale value, but the accuracy of this measurement may be outside of published specifications.

Purge—The Max-Trak Mass Flow Controller is supplied with the ability to open the valve far beyond the full scale position to allow them to be cleaned. This is usually accomplished by blowing clean, dry nitrogen through the instrument. When the valve is opened to this cleaning position, it is said to be in the Purge mode.

LFE—Laminar Flow Element (LFE) or bypass generates pressure drop forcing a small fraction of the total flow to pass through the sensor capillary tube.

THE MAX-TRAK FLOW SENSING PRINCIPLE

The operating principle of the Max-Trak instruments is based on heat transfer and the first law of thermodynamics. During operation process gas enters the instrument's flow body and divides into two flow paths, one through the sensor tube, the other through the laminar flow bypass. The laminar flow bypass (often called LFE which stands for "laminar flow element") generates a pressure drop, P_1-P_2 , forcing a small fraction of the total flow to pass through the sensor tube (\dot{m}_1).

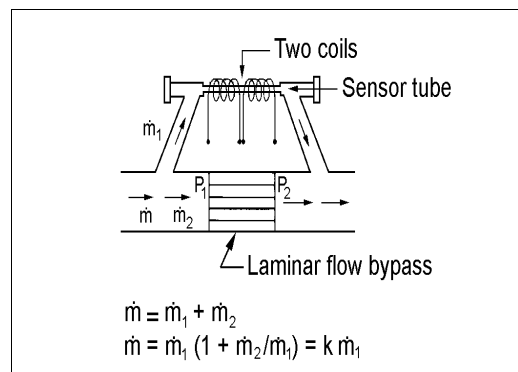

Figure 1-1. Flow Paths through the Instrument

Two resistance temperature detector (RTD) coils around the sensor tube direct a constant amount of heat (H) into the gas stream. During operation, the gas mass flow carries heat from the upstream coil to the downstream coil. The resulting temperature difference (ΔT) is measured by the Max-Trak microprocessor. From this, Max-Trak calculates the output signal. Since the molecules of the gas carry away the heat, the output signal is linearly proportional to gas mass flow.

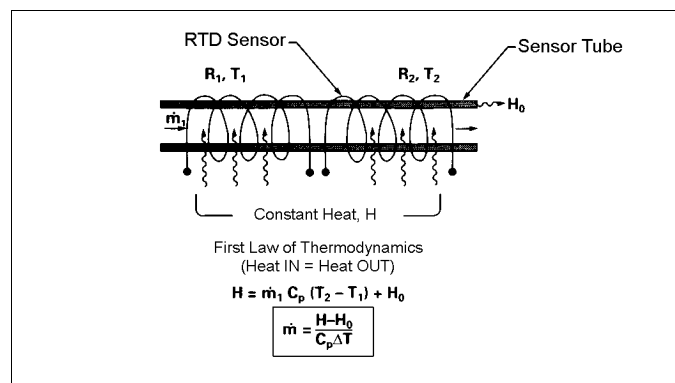

Figure 1-2. Flow Measuring Principle

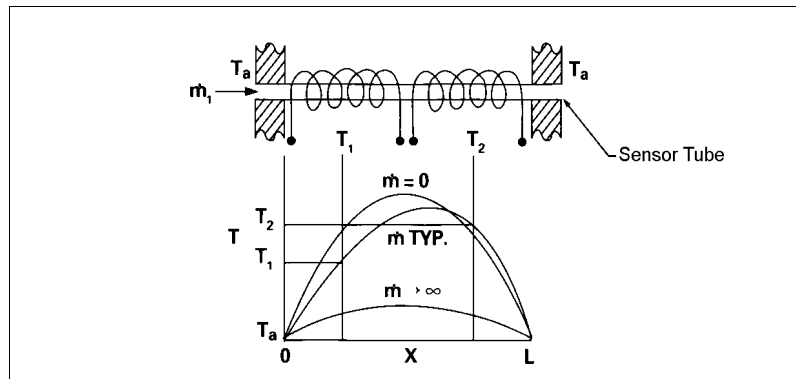

Figure 1-3. Sensor Temperature Distribution

Figures 1-2 and 1-3 show the mass flow through the sensor tube as inversely proportional to the temperature difference of the coils. The coils are legs of a bridge circuit with an output voltage in direct proportion to the difference in the coils' resistance; the result is the temperature difference (ΔT). Two other parameters, heat input (H) and coefficient of specific heat (C_p) are both constant. Through careful design and attention to these parameters, this output signal is made linear over the transducer's normal operating range (Figure 1-4). As a result, the measured flow through the sensor tube is directly proportional to the gas flow in the main body.

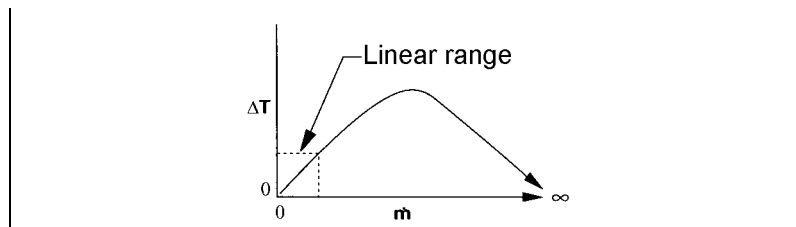

Figure 1-4. Linear Range of the Transducer's Output Signal

In the Max-Trak mass flow *controllers*, the gas which flows through the monitoring section is precisely regulated by the built-in electromagnetic valve. The normally closed valve is similar to an on/off solenoid valve, except that the current to the valve coil, and hence the magnetic field, is modulated so that the ferromagnetic valve armature, or valve plug, assumes the exact height above the valve's orifice required to maintain the valve's command flow (set point). The result is excellent resolution.

CHAPTER 2 INSTALLATION

Before You Begin Installation



Warning!
Injury can result if line pressure exceeds the maximum rating of 500 psig (34 barg).

Before installing the instrument, ensure that the installation site conforms to the specific operating parameters recorded on the instrument's Data Label. The Data Label is mounted on the back of the instrument electronics enclosure (see samples below). Should the data label on the back of the instrument become illegible due to exposure or age, a duplicate of this label is included INSIDE the enclosure for reference. Because each instrument is configured for a specific application range it is critical to verify these details before operation. Please review the gas or gases, the mounting orientation, the maximum flow range(s), the inlet and outlet pressure(s), and the operating temperature(s). The line pressure should not exceed 500 psig (34 barg). The temperature should not exceed 50°C (122°F). The minimum operating gas temperature is 0°C (32°F) and ambient temperature must remain between -20 to 50°C. If your application exceeds any of these parameters, contact your Sierra Sales Agent before installation. You may also contact one of Sierra's Technical Support Centers. FACTORY USA: TOLL FREE: 800-866-0200 or PHONE: 831-373-0200 or FAX: 831-373-4402 or EMAIL: service@sierrainstruments.com

Figure 2-1: Examples of Data Labels

SIERRA INSTRUMENTS, INC. THE MASS FLOW COMPANY			5 Harris Court Bldg. L Monterey, Ca. 93940 800-866-0200 831-373-0200		
Mass Flow Controller					
Model					
C100L-L-DD-LE-5-OV1-SV1-PV1C-V1-S1					
Serial	Order	Mfg. Date			
10067	10001	7/1/03			
Gas					
Air					
Range & Units			STP		
0-1 SLPM			70F / 1 ATM		
Output Signal			Set Signal		
0-5 Vdc			0-5 Vdc		
Orientation			Supply		
Horizontal			12-15 Vdc		
Inlet Press.	Outlet Press.	Max. Press.			
30 PSI	ATM	500 PSIG			
Oper. Temp	Max. Temp	Connections			
70F	122F	1/4" VCO			
O-ring Material			Valve Seat Material		
Viton			Viton		
Technician	Cal. Date	Recal. Date			
www.sierrasmarttrak.com					
Made in USA			ISO 9001 Registered		

SIERRA INSTRUMENTS, INC. THE MASS FLOW COMPANY			5 Harris Court Bldg. L Monterey, Ca. 93940 800-866-0200 831-373-0200		
Mass Flow Meter					
Model					
M100L-L-DD-LE-5-OV1-SV1-PV2-V4-S4					
Serial	Order	Mfg. Date			
10068	10001	7/1/03			
Gas					
Nitrogen					
Range & Units			STP		
0-1 NM3/hr			21C/760 mmHg		
Output Signal			Set Signal		
4-20 mA			4-20 mA		
Orientation			Supply		
Vertical Flow Down			24-30 Vdc		
Inlet Press.	Outlet Press.	Max. Press.			
2 BARG	ATM	35 BARG			
Oper. Temp	Max. Temp	Connections			
20C	50C	3/8 VCR			
O-ring Material			Valve Seat Material		
Viton			Viton		
Technician	Cal. Date	Recal. Date			
www.sierrasmarttrak.com					
Made in USA			ISO 9001 Registered		

Pre-Installation Check List

1. **Double-check to be sure that the o-ring material used in your instrument is compatible with the gas to be measured.** The o-ring material used in your Max-Trak can be found in the Data Label. See Appendix A for a table of elastomer compatibility with a wide variety of gases.
2. **Sierra strongly recommends you install an in-line filter upstream of the instrument.** Recommended filter size: 10 micron.
3. **Do not locate the instrument in areas subject to sudden temperature changes or near equipment radiating significant amounts of heat.** Be sure to allow adequate space for cable connectors and wiring. Max-Trak weighs up to 30 lbs (14 kg) so make certain mounting hardware is properly designed.
4. **For controllers, use a properly sized pressure regulator.** Make sure the pressure regulator is not too small or too big. There can be no restrictions (such as valves, tubing or pipe internal diameters, reducers, etc.) upstream or downstream of the controller with a dimension that is less than the valve orifice diameter. To determine orifice diameter, consult the calibration certificate included with your instrument.
5. **Output Signals:** The Max-Trak has two analog outputs that are linearly proportional to the gas mass flow rate. These are a 4-20 mA signal plus your choice of one voltage signal: 0-5 VDC or 0-10 VDC or 1-5 VDC. The voltage signal specified at time of order will be indicated on the data label. You may change between the current and the voltage output signal at your discretion after receipt of the instrument using the Remote Pilot Module or the Smart-Trak Software (see Chapters 4 & 5). Changing the voltage output has no influence on the instrument's accuracy.
6. **The instrument has specific power supply requirements.** See the table later in this chapter for a complete listing of power requirements.

Installing the Instrument—Plumbing

Max-Trak instruments are supplied with compression, VCO[®], VCR[®], or female NPT process connections. To ensure a successful installation, inlet and outlet tubing should be in a clean state prior to plumbing the instrument into the system. The shipping caps covering the inlet/outlet fittings should not be removed until immediately before installation.

Follow the installation instructions that are applicable to your instrument's process connection. Ensure that the tubing is free from burrs, or sharp rims that may result from cutting.



CAUTION: Before use, all plumbing should be checked carefully for leaks, especially at the connecting fittings. All instruments are leak-tested prior to shipping. If you choose to leak-check your new instrument, you may either monitor pressure decay or use liquid leak detectors such as Snoop[®] to search for leaks.

Compression Fittings

1. Position the instrument with the flow direction arrow pointing in the direction of flow.
2. Verify the position of the front and back ferrule. Insert the tubing into the fitting. Be sure that the tubing rests firmly on the shoulder of the fitting and that the nut is finger-tight. Scribe the nut at the six o'clock position.
3. While holding the fitting body steady with a backup wrench, tighten the nut 1-1/4 turns, watching the scribe mark make one complete revolution and continue to the nine o'clock position. For 1/16-inch, 1/8-inch and 3/16-inch (2, 3 and 4 mm) sizes, tighten only 3/4 turns from finger-tight. **Do not over-tighten!**
4. If you use flexible tubing (Example: Polyflow) use an "Insert" (see www.swagelok.com)
5. Check the system's entire flow path thoroughly for leaks.

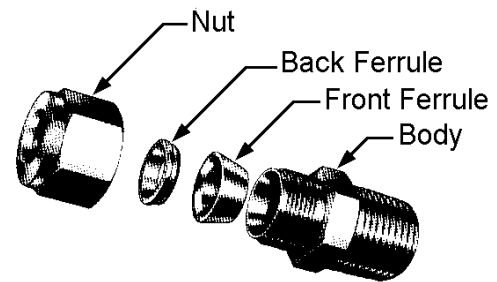

VCO Fittings

1. Position the instrument with the flow direction arrow pointing in the direction of flow.
2. Tighten the nut finger-tight, and then 1/8 turn tighter with a wrench. **Do not over-tighten!**
3. Check the system's entire flow path thoroughly for leaks.

VCR Fittings

1. Position the instrument with the flow direction arrow pointing the direction of flow.
2. Install new gaskets that are compatible with the gas to be used.
3. Tighten the nut finger-tight, and then 1/8 turn tighter with a wrench. **Do not over-tighten!**
4. Check the system's entire flow path thoroughly for leaks.

Female NPT

1. Position the transducer with the flow direction arrow pointing the direction of flow.
2. Use a good quality Teflon tape. Apply to the male fittings. Alternatively, use a high quality paste pipe thread sealant suitable for the application and gas and apply this compound to the inlet and outlet fittings. Avoid getting the tape or the thread sealant onto the first two threads to keep it out of your process gas.
3. Tighten each fitting by hand. Then, tighten no more than one (1) turn. **Do not over-tighten.**
4. Check the system's entire flow path thoroughly for leaks

Installing your Instrument—Mechanical Mounting

Mounting your Instrument

The base plate or bottom of the instrument has 4 mounting holes. Two are SAE thread and two are metric thread. For location and dimensions, please see Appendix E. Remember to properly support the weight of your instrument.

The Optional Remote Pilot Module

If you have the optional Remote Pilot Module control unit, it is designed to be used on a temporary basis to configure your Max-Trak at installation or for trouble-shooting Max-Trak in the future. It is not designed for continuous use with Max-Trak as the Remote Pilot Module is not water-resistant. See Chapter 5 for use of the Remote Pilot Module.

Installing your Instrument—Electrical Connections



CAUTION: DO NOT APPLY POWER TO THE OUTPUT LOOP on units equipped and calibrated for a 4-20 mA output signal. This is NOT a loop-powered device. Damage will occur.

All electrical connections for your Max-Trak instrument are made on the left (inlet) side panel. There are 3 options for making electrical connection which must be specified at time of order: a waterproof electrical connector (WT in the model code), a cable gland (GLAND in the model code) or an open port for conduit connection (COND in the model code). These will be discussed separately.

Using Water Tight (WT) Cables

If your instrument has the WT option, attach the water-tight cable to the electrical connector on the inlet side of the instrument. Connect the wires in this cable per the diagram below. **You do not need to open the instrument if you have ordered the WT option.**

Using the Cable Gland or Conduit

If your instrument has our 1/2 FNPT conduit port (code COND) or a cable gland (code GLAND), you must remove the top of the instrument for installation. All electrical connections, including power, are applied via the terminal strip which is located INSIDE the waterproof enclosure. Access is through the port or cable located on the inlet side of the enclosure.

Opening the Max-Trak Instrument

1. Remove the top section of the enclosure by unscrewing the 4 mounting bolts on the top of the instrument (bolt size SAE 7/16"). Gently pry the top section off the instrument (not the complete cover, just the top section). Do not remove the O-ring seal around the perimeter of the enclosure.
2. If using conduit, run your wires through the conduit, connect the conduit to our ½" FNPT port on the inlet side of the instrument with Teflon tape or pipe thread sealant, then pass your wires into the instrument toward the terminal strip (at the top). If using the cable gland, run your shielded cable with a diameter of 0.20-0.35" (5-9 mm) through the special gland on the side of the enclosure (cable with a smaller ID may allow liquid to enter the instrument and cause permanent damage). Do not remove the cable gland.
3. Separate your individual wires (16-28 gauge required) and connect to the terminal strip on the top of the upper circuit board. Wire per the diagrams below. Note that this terminal strip is unique to the Max-Trak 180 Series instruments.
4. When wiring is completed, secure the conduit to the enclosure in a watertight fashion or tighten the cable gland fitting so that it grasps your cable securely. Failure to seal the conduit to the enclosure or to tighten the fitting can permit liquid to enter the electronic compartment and damage the instrument.
5. Install the top section of the enclosure taking care not to pinch the O-ring seal or any of your wires. Insert and tighten the 4 mounting bolts. Failure to install these bolts correctly can permit liquid to enter the electronic compartment and damage the instrument.

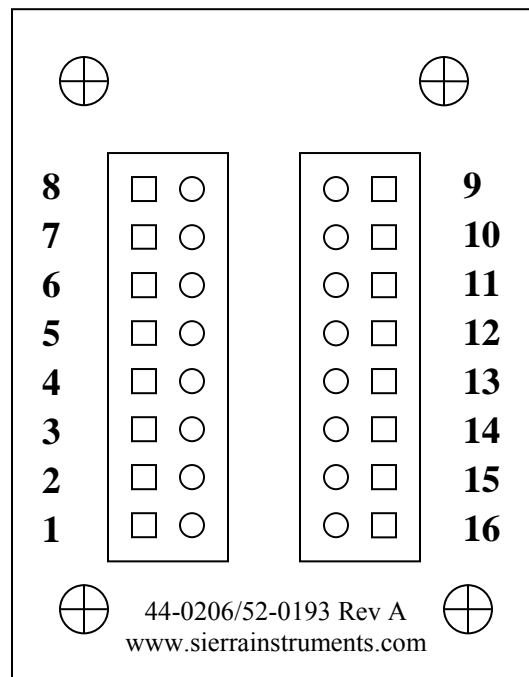
Terminal Strip PCA Pin Configuration (inside the enclosure)Wiring Functions, Location and Color Codes

#	Function	Wire Color with optional WT cable
1.	Analog Ground	Brown
2.	0-5 VDC Output (or 0-10, 1-5 VDC)	Red
3.	Analog Ground	Orange
4.	Valve Override (purge)	NOT CONNECTED
5.	Power Return (-)	Yellow
6.	Power Input (+)	Green
7.	RS-232 Transmit (out)	Purple
8.	Setpoint	Blue
9.	Not Used	NOT CONNECTED
10.	Analog Ground	Gray
11.	Reference Voltage (5 VDC External Setpoint & Valve Purge)	NOT CONNECTED
12.	Valve Override (close)	Black
13.	RS-232 Receive (in)	Pink
14.	4-20 mA Output	White
15.	Chassis (Earth) Ground	Tan (light Brown)
16.	Not Used	NOT CONNECTED

Note: Pins 1, 3, 5, and 10 are connected together inside the instrument. Sierra recommends individual wires.

Basic Analog Installation of the Instrument



CAUTION: This instrument is not a loop-powered device! Do NOT apply power to the 4-20 mA output or input connections.

- **Instrument Power:** The Max-Trak requires a 24 VDC power supply. If you are using the power supply supplied by Sierra, connect it as noted above. If you are supplying your own power source, it must be a regulated source with ripple not to exceed 100 mV peak-to-peak. Refer to the table below for voltage and current requirements. Max-Trak is polarity sensitive. If you reverse this wiring, the instrument will not be damaged, but it will not function.

Power Supply Requirements

Instrument Type	Recommended Input Voltage	Minimum Current Required (mA)
M180M Meter	15-24 VDC ($\pm 10\%$)	130
M180H Meter	15-24 VDC ($\pm 10\%$)	130
C180M Controller	24 VDC ($\pm 10\%$)	700
C180H Controller	24 VDC ($\pm 10\%$)	1260

- **Output Signal—Voltage:** Measure the voltage output signal across the red (pin 2) wire and any of the analog grounds: brown (pin 1), orange (pin 3) or gray (pin 10). The minimum load is 1000 Ohms.
- **Output Signal—Current:** Measure the current output signal, 4-20 mA across the white (pin 14) wire and any of the analog grounds: pin 1, 3, or 10. The maximum load is 500 Ohms.

For Mass Flow Controllers, the following features are also available:

- **Setpoint:** To transmit an analog setpoint, supply the voltage or current signal (user selectable) across the blue (pin 8) wire and any of the analog grounds: pin 1, 3, or 10. Note that the setpoint signal you supply must match the signal type your instrument is configured for. See Chapters 4 and 5 for how to change the type of setpoint source.
- **Valve Close:** To force the valve closed, connect the black (pin 12) wire to one of the analog grounds.
- **Purge:** To force the valve to its maximum open position which we call “Purge,” connect pin 4 to pin 11. Note that this will allow much greater flow than the rated full-scale value.

Note: In the Series 180 instrument with WT option only, the 2 pins for Valve Purge are not connected at the factory. To activate this feature, open the top of the enclosure and move any 2 wires you are not using to the proper terminal strip location.

Valve Purge	Terminal Pin # 4
5Vdc ref voltage	Terminal Pin # 11 (activates Purge function)

Configuring your Instrument

The Max-Trak instruments have many features which can be changed by the user. You may wish to review these features and modify some of them prior to operation of your instrument. This must be accomplished using Digital Communication with the supplied Smart-Trak software or the Sierra Remote Pilot Module user interface. If you prefer to use your instrument as delivered, please proceed to Chapter 3: Analog Operation.

Using Smart-Trak software to Configure Your Instrument:

You can communicate with your instrument using the Smart-Trak Software package (provided with your purchase) and your PC running the Windows operating system. Simply connect the purple (pin 7) wire, the pink (pin 13) wire and one of the analog grounds: brown, orange or gray wires (pin 1, 3, or 10) to a standard DB-9 connector according to the chart below.

RS-232 Wiring Configuration

RS-232 Transmit (pin7)	to	DB-9 pin #2
RS-232 Receive (pin 13)	to	DB-9 pin #3
Analog ground (pin 1,3, or10)	to	DB-9 pin #5

With the connections above in place, plug the DB-9 connector into an appropriate serial port on your PC. If you are in an environment with high RF interference, it may be necessary to shield these wires. Should your computer not have a serial port, you will need a serial to USB adapter. See Chapter 4 for details.

You are now ready to configure your Max-Trak instrument. Proceed to Chapter 4 for a discussion of the use of the Smart-Trak software.

Using the Remote Pilot Module to Configure your Instrument

You can use the Sierra Remote Pilot Module hand-held interface to configure your instrument in the field. To connect the Remote Pilot Module to the Max-Trak instrument, remove the 4 screws and the top cover as described above in Opening the Max-Trak Instrument (page 2-6). Under the terminal strip PCA you will find an RJ-45 male connector. Carefully pull this out from its storage location under the terminal PCA. This connector has about 3 inches (75 mm) of wire for your convenience. Connect the Remote Pilot Module to this RJ-45 connector using one of the sockets on the Module. Proceed to Chapter 5 for a discussion of the use of the Pilot Module to configure your instrument.



CAUTION: The RJ-45 connector inside of the Max-Trak is **NOT** an Ethernet connector. It is for use with the optional Remote Pilot Module. Do not plug an Ethernet cable here as damage may result.

CHAPTER 3: ANALOG OPERATION

Your Max-Trak instrument may be operated in two different ways:

1. **Analog Input/Output Operation (This Chapter):** Using analog input/output signals at the 15-pin mini-D connector.
2. **Digital Operation with RS-232 and Smart-Trak Software (Chapter 4):** Using the RS-232 link, the supplied Smart-Trak Software package and a PC-style computer running the Windows operating system.

This chapter will discuss the first of these—Analog Operation. Please see Chapter 4 for digital operation.

Regardless of control options, the standard output for all Max-Trak instruments are two linear analog output signals corresponding to 0% to 100% of the mass flow full-scale range. Please note that one of these output signals is always a current signal of 4-20 mA. The other is a user-configurable voltage signal of 0-5 VDC, 0-10 VDC or 1-5 VDC.

For mass flow controllers, one input signal of 4-20 mA, 0-5 VDC, 0-10 VDC or 1-5 VDC (selectable by user) may be chosen to set the gas mass flow rate to any desired value within the range of the device. This input signal must be a direct linear representation of 0% to 100% of the desired gas mass flow full-scale value.

For the location of these signals on the WT connector or the Terminal Strip, refer to Chapter 2.

Analog Operation, Mass Flow Meters (see below for Controllers)

After your instrument is installed and the system has undergone a complete leak check as discussed in detail in Chapter 2, you are ready to supply power.



Caution!

The Max-Trak is not a loop-powered device. Do not apply power to the 4-20 outputs.

Power Your Instrument: Apply power using Sierra's power supply or your own power source. See Chapter 2 for complete Power Supply requirements. Let the instrument warm up for at least 15 minutes for optimal performance. Check the configuration of your instrument by reviewing the data label details.

If the configuration is not correct for your present application, you can alter it. See Chapter 4 or 5 for details on how to change the configuration of your Max-Trak instrument.

If the configuration is correct,

Your Max-Trak instrument is now ready for use!

Analog Operation, Mass Flow Controllers

After your instrument is installed and the system has undergone a complete leak check as discussed in detail in Chapter 2, follow these steps:

1. **The valve will remain closed until power is supplied.** See Chapter 2 for wiring instructions. Remember that the valve in the Max-Trak is not a positive shut-off device. When power is applied, the flow control valve will operate per any instructions it receives. When the Max-Trak is delivered, the valve will be in the Automatic (Normal) state and the analog or digital command signal will provide the correct zero setpoint reference for the instrument. As a result, the valve will be closed. However, upon subsequent power-ups, the valve will return to the state it was in the last time the instrument was operated.



CAUTION: If you do not know the value of the setpoint or the valve state given to the Max-Trak when it was last operated, you must assume that the valve will open when power is applied. Take necessary precautions. You may use the Pilot Module or the Max-Trak Software to check the setpoint or the valve state currently on your instrument. See Chapter 4 or Chapter 5 for information on Setpoint and Valve State.

2. **Power Your Instrument:** Apply power using Sierra's power supply or your own power source. See Chapter 2 for complete Power Supply requirements.
3. **Adjust the controller setpoint to the desired flow rate by supplying an appropriate signal (mA or VDC).** The effective control range of the unit is 2% to 100% of the calibrated full scale flow range. Automatic shut-off occurs at 1.9% of the factory full scale calibrated range. Max-Trak will immediately begin accurately monitoring and controlling the gas mass flow rate. Let the instrument warm up for at least 15 minutes for optimal performance. Note: you must supply the setpoint in the configuration the Max-Trak is looking for. If the instrument does not respond to your set-

point, check the configuration on the data label and re-configure the instrument as needed (see Chapters 4 and 5)

Your Max-Trak instrument is now ready for use!

Max-Trak Analog Features

Setpoint Adjustment (flow controllers only)

The setpoint (command) input signal you supply to Max-Trak must be a direct linear representation of 0% to 100% of the mass flow full-scale value. Apply the setpoint signal from pin 8 to any of the analog grounds (see Chapter 2 for wiring details). A setpoint value of 0 VDC (or 1 VDC or 4 mA) will regulate the flow to 0% and a setpoint value of 5.00 VDC (or 10 VDC or 20 mA) will adjust the flow to 100% of the instrument's full scale range.

When the setpoint (command) signal is applied, the flow controller will reach the setpoint value within two seconds to within $\pm 2\%$ of the selected flow rate.



Caution!

CAUTION: DO NOT LEAVE A SETPOINT APPLIED FOR AN EXTENDED PERIOD OF TIME TO A CONTROLLER WHEN THE GAS SUPPLY IS SHUT OFF OR BLOCKED. This will overheat your instrument which will become hot to the touch and damage may result. Instead, drive the set point to zero or use the "Valve Close" feature which allows you to disable the valve while maintaining the current setpoint signal. Valve Close may be activated from an external analog signal (see below) or digitally (see Chapters 4 and 5).

Changing the Output or Setpoint Signals

To modify the analog output or setpoint signals (from 4-20mA to 0-10Vdc, for example), you must use the Pilot Module or the Smart-Trak Software. The data label will indicate the form these signals had when the instrument was last calibrated. We strongly recommend that you modify the data label if the configuration is changed for future reference. See Chapter 4 or 5 for the necessary procedure. Remember that the Max-Trak will always output a current signal of 4-20mA. The other output signal and the setpoint signal may be changed using this procedure.

Over-Range Condition

If the mass flow rate exceeds the full-scale range listed on the Max-Trak data label (see samples of the data label in Chapter 2, page 2-1), the output signal will measure above full-scale. However, the device has not been calibrated for flows in excess of the calibrated full scale value and the resulting output will be both non-linear and inaccurate if an over-range condition exists. Please be aware that the analog outputs can exceed full scale by as much as 20%, or more.

Once the over-range condition has been removed, it may take up to 30 seconds for the Max-Trak to recover and resume normal operation. An over-range condition will not harm the instrument.

Manual Valve Override—Valve Close

Manual valve override is provided for all Sierra mass flow controllers. This feature includes both a valve close command and a valve maximum open command (called purge). When the valve is directed to close or to purge, it will no longer respond to a setpoint command.



Caution!

The Max-Trak valve is not a positive shut-off device.

FOR VALVE CLOSE: connect pin 12 (black wire with WT cable) to one of the analog grounds.

The Controller will return to normal automatic operation about 4 seconds after pin 12 is left floating.

Manual Valve Override—Valve Purge Function

The purge function opens the controller valve completely for the purpose of quickly flushing unwanted gas from the flow path. When the valve is opened for purging, it allows flows far in excess of the rated full scale of the controller.

FOR VALVE PURGE: connect pin 4 to pin 11.

Note: with the WT option, this feature is disabled at the factory. If you want to use this feature, you must select 2 wires not currently in use and connect them as indicated at the terminal strip INSIDE the instrument. See Chapter 2 for more details.

IMPORTANT NOTES ABOUT PURGING

**Caution!**

Always fully neutralize any toxic gas trapped inside the instrument before removing it from the gas line.

Purging Non-Reactive Gases:

Purge your Max-Trak with clean, dry nitrogen for a minimum of two hours.

Purging Reactive Gases:

One of the following methods may be used:

- ❖ Cycle purge. This is done by alternately evacuating and purging the instrument for 2 to 4 hours with clean, dry nitrogen.
- ❖ Purge the instrument with clean, dry nitrogen for 18 to 24 hours.
- ❖ Evacuate the instrument for 18 to 24 hours.

SAFETY NOTES WHEN PURGING



WARNING: When toxic or corrosive gases are used, purge unit thoroughly with inert dry gas before disconnecting from the gas line to prevent personnel from being injured when coming in contact with the instrument. Chapter 3 discusses how to purge your instrument.



WARNING: If an instrument used with a toxic or corrosive gas is returned to the factory, a Material Safety Data Sheet (MSDS) must be enclosed & attached to the outside of the box to alert Sierra personnel of the potential hazard. Also, make sure the inlet & outlet are securely sealed.

CHAPTER 4: DIGITAL OPERATION RS-232 & SMART-TRAK SOFTWARE

Your Max-Trak instrument may be operated in two different ways:

1. **Analog Operation (Chapter 3):** Using analog input/output signals at the WT connector or terminal strip.
2. **Digital Operation with RS-232 and Smart-Trak Software (This Chapter):** Using the RS-232 Smart-Trak Software package and a PC-style computer running the Windows operating system.

This chapter will discuss Digital Operation with your computer via RS-232 and Smart-Trak Software. Although you have chosen to use the RS-232 option, please note that all the Analog control functions are still available on your instrument. Consult Chapter 3 for details on Analog operation. Also, the optional Remote Pilot Module may be used to configure your instrument so long as you disable RS-232 communication during that phase. See Chapter 5 for details on configuration using the Remote Pilot Module.

If you prefer to write your own software to communicate with the Smart-Trak over the RS-232 link, this is certainly possible. Sierra Instruments makes the Source Code including the Command Set available on the CD ROM supplied with your instrument. Unfortunately, this is the limit of software Technical Support we can extend.

SUMMARY OF THE MAX-TRAK FEATURES

Your Max-Trak instrument may be easily monitored and adjusted using the supplied Smart-Trak Software package. The software allows you to see all changes & parameters at a glance and will allow you to make changes quickly and easily to your instrument. You can also re-configure your instrument with the software. The features of your Max-Trak include:

1. Top Level Screens that display information (no password is required to view this information). In our software, these screens appear as yellow boxes. They include:
 - ❖ Mass flow rate
 - ❖ Gas (10 options pre-programmed, one must be AIR)
 - ❖ Engineering units (mass per unit time)
 - ❖ Current Setpoint with units
 - ❖ Source of Setpoint (analog or digital and type)
 - ❖ Valve operation mode (normal, valve shut or purge)
 - ❖ Current meter full scale value with units (user selectable)

2. Lower level Screens that permit changes to instrument operation (this level is password protected). In our software, these screens appear as white boxes. They include:
 - ❖ Setpoint value
 - ❖ Engineering units
 - ❖ Gas
 - ❖ Valve operation
 - ❖ Source of the setpoint signal
 - ❖ Form of the output signals
 - ❖ Full scale of the instrument
 - ❖ Password

3. Additional Features include:
 - ❖ Re-boot the Smart-Trak microprocessor
 - ❖ Change the Communication Port

POWER YOUR INSTRUMENT



CAUTION: The Smart-Trak is not a loop-powered device. Do not apply power to the 4-20mA outputs.

After your instrument is installed and the system has undergone a complete leak check (discussed in detail in Chapter 2), apply power using Sierra's power supply or your own input power source. See Chapter 2, for power supply requirements and wiring information.

If you have a Mass Flow Controller, the valve will remain closed until power is supplied. Remember that the valve in the Smart-Trak controller is not a positive shut-off device. When power is applied, the flow control valve will operate per any instructions it receives. When the Smart-Trak is delivered, the valve will be in the Automatic (Normal) state. As a result, the valve will be closed. However, if the instrument has been used before, the valve will return to the state it was in the last time the instrument was operated.

CAUTION: If you do not know the position of the valve before it was shut down, you must assume that the valve will open when power is applied. Take necessary precautions.



POWER YOUR COMPUTER

Apply power to your computer per the manufacturer's recommendations. The Smart-Trak Software is compatible with any computer running the following Windows Operating Systems:

Windows 98, 2nd Edition
Windows XP
Windows XP Professional
Windows 2000

LOADING THE SMART-TRAK SOFTWARE

If you are using your Max-Trak instrument or your computer for the first time, it is necessary to install the Smart-Trak Software into your computer. If this software is already installed, skip this section. If you want to upgrade the Smart-Trak Software because you have a higher revision, continue below.

Each Max-Trak order is shipped with a CD-ROM containing the Smart-Trak Software. Locate this disk. At this point, **EXIT OUT OF ANY OPEN APPLICATIONS BEING RUN ON YOUR COMPUTER.**

PROCEDURE:

1. Insert the Smart-Trak Software CD into your CD-ROM
2. Open “My Computer” on your desktop
3. Open the CD Named: “Smart-Trak” on your D-drive
4. Run “setup.exe”
5. Follow the instructions on screen

CAUTION: It is recommended that you do not change the default installation directory for this software. The default directory is C-drive:\ Program Files. Changing the installation directory may lead to malfunctions in the software.



CONNECTING MAX-TRAK TO YOUR COMPUTER

If your computer has a serial port...

You must connect the RS-232 transmit, receive and ground pins or wires to a DB-9 connector. See Chapter 2 for wiring instructions.

With your Max-Trak **POWERED**, plug the DB-9 connector to an appropriate serial port on your computer. Note the serial port channel number, especially if there is more than one serial port available. If your computer has only one serial port, it is often named “Comm Port 1.” You will need to know the Comm Port number to communicate with your Smart-Trak instrument.

If your computer has no serial port, but has a USB port...

Perform the identical connections as if your computer has a serial port (see previous paragraph), but do not plug the DB-9 connector into your computer. Instead, purchase an appropriate Serial to USB converter. Plug the DB-9 connector into your Serial to USB converter and then plug the USB connector into your computer. Load the necessary software driver into your computer to operate the converter (software and instructions should come with the converter).

Your computer will assign a Comm Port number to your USB adapter, but it will probably not be “Comm Port 1.” Use the Control Panel feature of your computer to identify which Comm Port number has been assigned to your USB adapter.

Open “My Computer” from your desktop.

Next, open “Control Panel.”

Then, open “System.”

Click on the tab labeled “Device Manager.”

Scan down the list until you see the word “Ports,” then right double-click to examine the available Com Ports. Record the number(s). You will need to enter this number or one of these numbers to communicate with your Smart-Trak instrument.

If you plan to control more than one Max-Trak instrument from your computer...

If your computer has a number of serial ports equal to the number of instruments you wish to operate, simply plug each instrument into a separate serial port as directed above in “If your Computer has a Serial Port...”

If you wish to operate more instruments than your computer has serial ports, you will usually have to use USB ports instead. If the number of USB ports in your computer equals the number of instruments, then purchase one serial to USB converter per Smart-Trak and follow the instructions above. If you have more instruments than ports, you will need to acquire an edge port device (converts one USB port into several serial ports) or a USB hub (converts one USB port into many USB ports). Once you have attached the necessary device and loaded the proper drivers, connect your Smart-Trak instruments to the serial or USB ports as outlined in the sections above. Open a separate software window for each meter and you can monitor all of them at one time.

If connecting your computer to the Max-Trak creates any confusion, please contact Sierra Instruments or your IT person for assistance.

RUNNING THE SMART-TRAK SOFTWARE

Locate the file named “Smart-Trak” and open it. You will see the following screen:

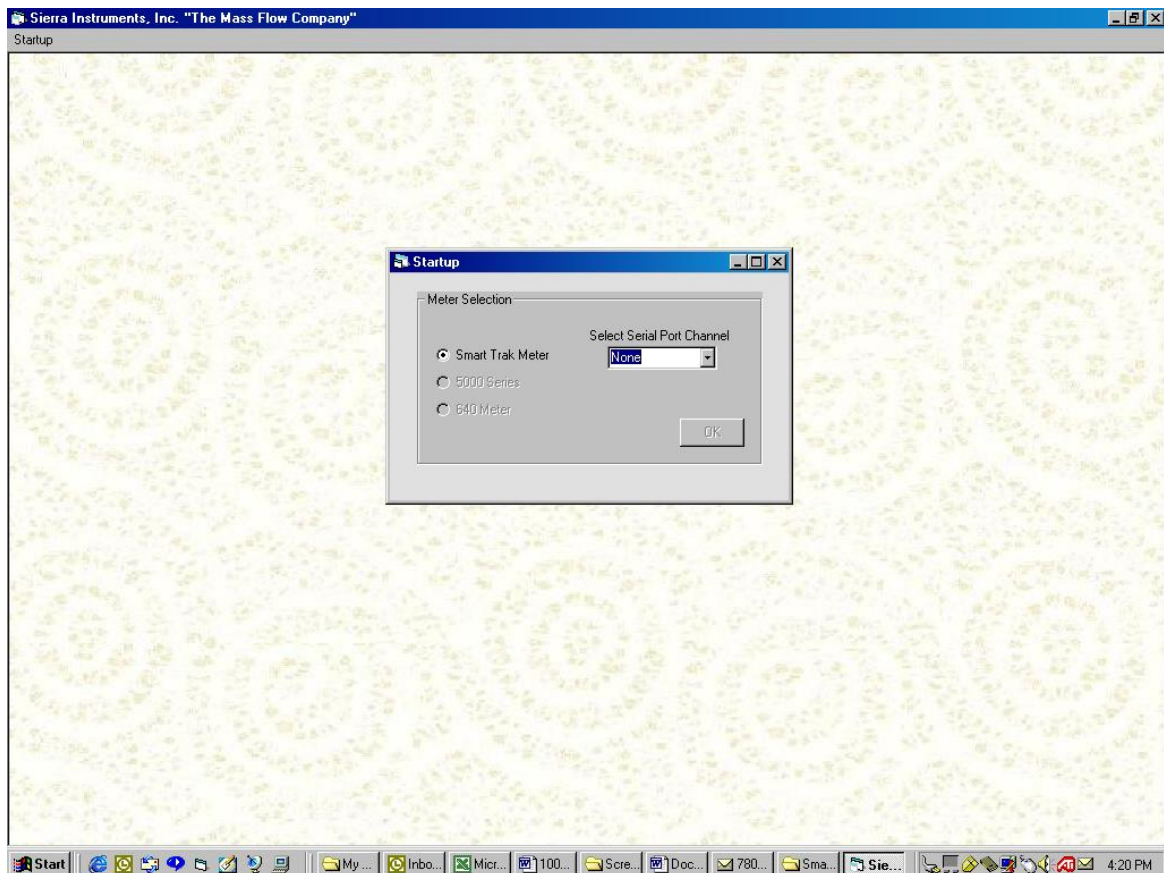

The prompt will ask you to select a serial port channel (“Comm port number”). Use the pull-down menu to choose the port number that corresponds to the serial port channel your Smart-Trak is connected to. If you have only one serial port, select “Comm Port 1.” When finished, click on the box marked “OK.”

Now, the Smart-Trak Master Screen will appear. There are two versions of this screen, one for Mass Flow Meters and the other for Mass Flow Controllers.

For Mass Flow Meters, the screen will appear like this:

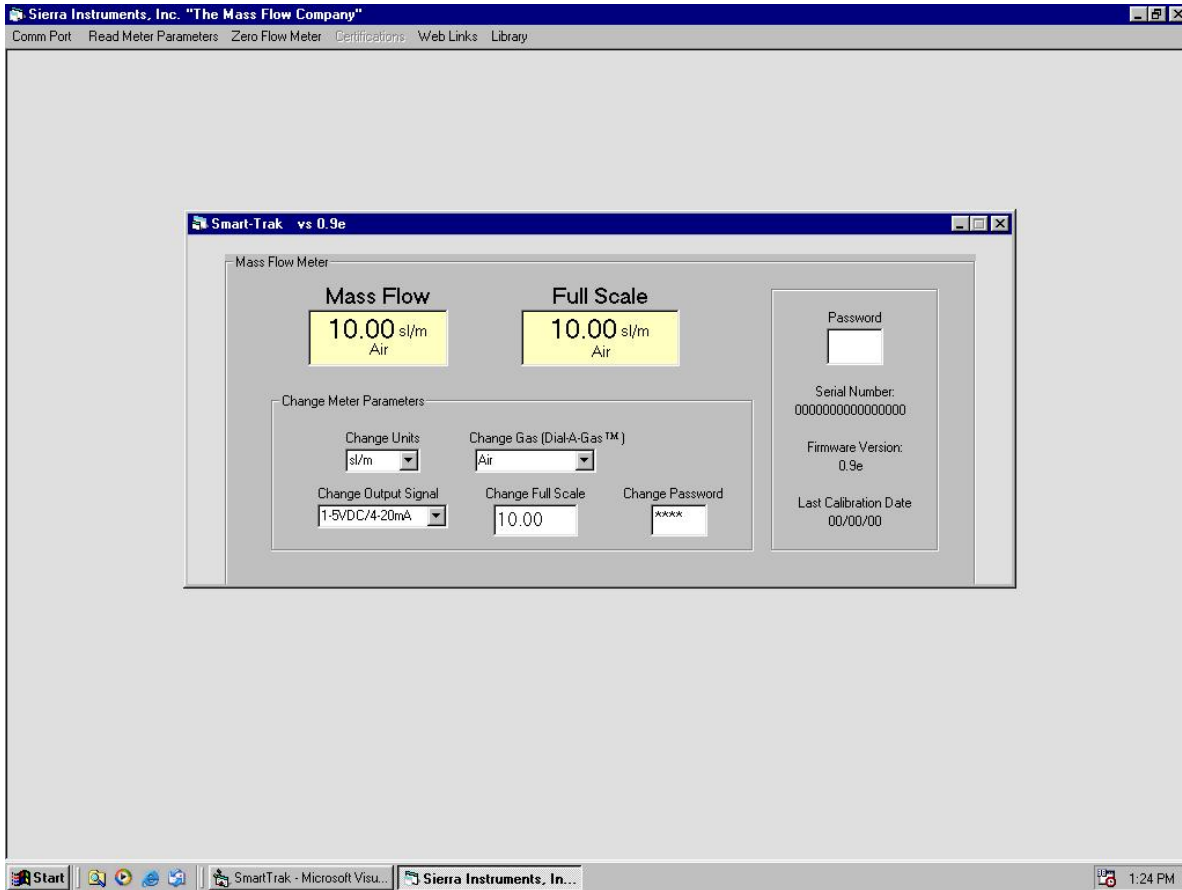

For Mass Flow Controllers, the following screen will appear:

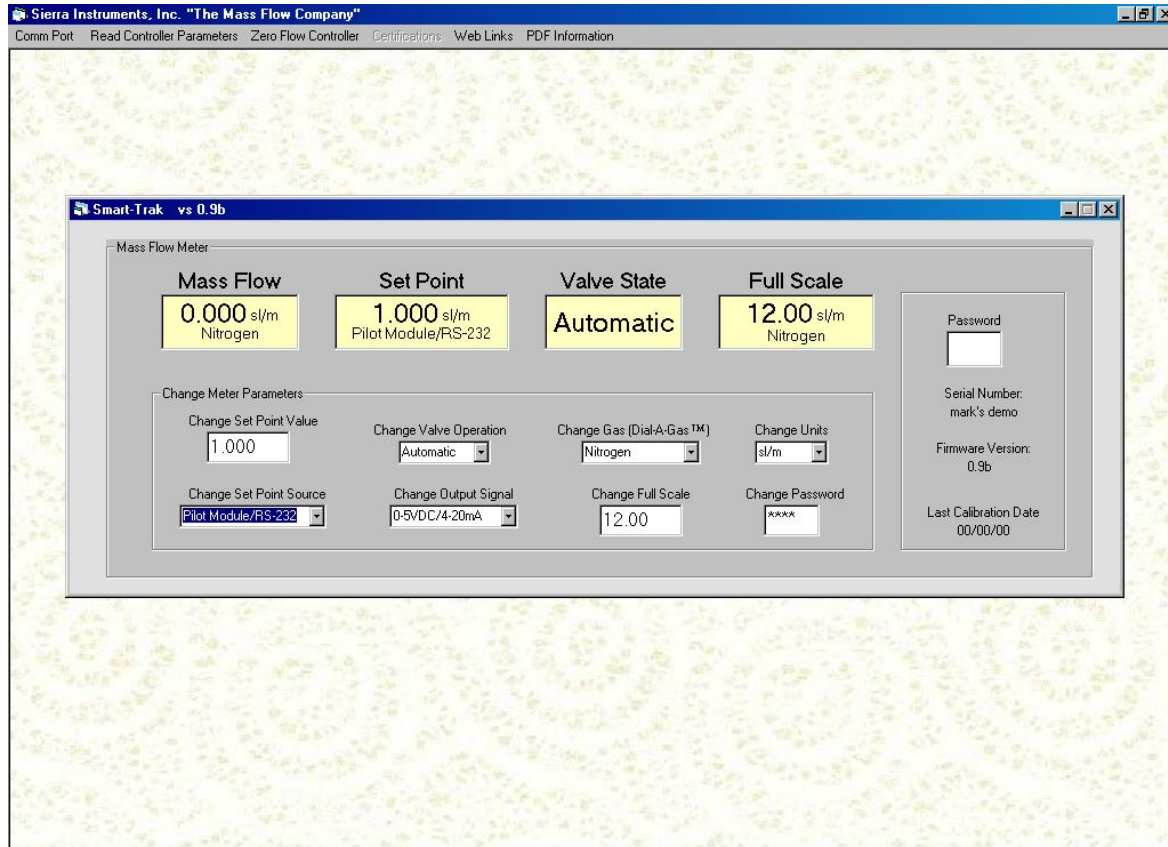

Establishing Communication

If the screen appears as above with all the yellow and white boxes full (with the exception of the password box), the Smart-Trak instrument has established communication with your computer. Proceed to the next section.

If the screen appears, but the yellow and white boxes are all empty, you have selected the wrong "Comm Port number." See the section titled "Comm Port" on page 5-16 for instructions on how to change the communication port number.

If the screen appears, but only the Mass Flow box shows a value, you are using the correct Comm Port, but your computer is not talking to the Smart-Trak. To begin communication, move the mouse pointer to the upper left corner of the screen and left click on the words "Read Controller Parameters." These words will appear in the Mass Flow box for a few

seconds and then values will fill all the boxes on the screen. Communication has been established. Your computer is now able to control your Max-Trak instrument. Let the instrument warm up for at least 15 minutes for optimal performance.

Your Smart-Trak instrument is now ready for use!

USING THE SMART-TRAK SOFTWARE

A. UPPER SECTION OF SOFTWARE WINDOW

Across the upper half of the Smart-Trak Software window you will see 4 yellow boxes. These are titled:

- ❖ Mass Flow
- ❖ Setpoint (flow controllers only)
- ❖ Valve State (flow controllers only)
- ❖ Full Scale

These boxes display the current operating conditions of your Smart-Trak instrument. If you have the Pilot Module, these boxes on the upper half of the software screen are identical to the Upper Level Screens on the Pilot Module discussed in Chapter 4. The features of these boxes are described below.

Mass Flow

The box displays the mass flow rate, the engineering units and the gas choice.

Set Point

If you have a Mass Flow Meter, this box is omitted. The Set Point box displays the current setpoint given to the flow controller, the engineering units and the source of the setpoint signal.



CAUTION: If this box does not show Pilot Module/RS-232 at the bottom, you will not be able to give the flow controller a setpoint command from your computer. This is because you Max-Trak is expecting an analog setpoint. To supply a setpoint from your computer, see “Change Setpoint Source” on page 4-13 below.

Valve State

If you have a Mass Flow Meter, this box can be bypassed. For normal operation of the flow controller, this box should display:

Automatic

If this is visible, the instrument will automatically control flow as soon as a setpoint is given to it.



CAUTION: If this box does not display “Automatic,” it will not be possible to control gas flow. Your valve is in override--either locked open (Purge) or closed (Closed). See the section titled “Change Valve Operation” below for further instructions

Full Scale

This screen displays the current full-scale value of the instrument with engineering units. It also displays the gas. Over to the right, below the Password, you can find the factory full scale maximum (maximum flow rate for the instrument).

B. PASSWORD SECTION

To the right of these yellow boxes is the white password box. In order to make a change to the Smart-Trak, including giving the instrument a setpoint, you must first enter the correct password in this box. The password must be four digits in length. The factory default password is “0000.”

Note that this password is the same one used with the Pilot Module. Until you enter the correct password, you will not be able to change any of the values in the lower boxes.

C. LOWER SECTION OF SOFTWARE WINDOW— CHANGING PARAMETERS AND CONFIGURATION OF THE INSTRUMENT

Across the bottom half of the screen you will find a section titled “Change Meter Parameters” and you will see a number of white boxes. Each box allows you to adjust one or more meter functions. These boxes will not function until the appropriate password is entered (see Password section above). The various functions are reviewed in the following section.

Change Setpoint Value (flow controllers only)

The first of the white boxes is the Change Setpoint Value box. This is the box that allows you to change the setpoint of the mass flow controller. To make a change to the setpoint value, move your pointer to this box and left click. You may change a digit or delete the current setpoint and key in a new one. When you have made your selection, press the enter key to implement it.



CAUTION: Verify your setpoint selection before you press the enter key. Once you press enter, the Max-Trak will change the setpoint to the new value, even if it is not what you intended.

The white box will show your new setpoint value and within a few seconds, the large yellow box above titled “Set Point” will also show your new selection. If there is gas to the instrument, the Mass Flow box should also show the flow increase or decrease until the new setpoint is reached.

Note: you cannot enter a setpoint greater than the value displayed in the yellow Full Scale box. If you do so, the Smart-Trak software will modify your setpoint selection so that it is equal to the Full Scale value when you press the enter key.



CAUTION: DO NOT LEAVE A SETPOINT APPLIED FOR MORE THAN 5 MINUTES TO A CONTROLLER WHEN THE GAS SUPPLY IS SHUT OFF OR BLOCKED. Your instrument will over-heat, become hot to the touch, and damage may result. Instead, adjust the setpoint to zero or use the “Valve Close” feature which allows you to disable the valve while maintaining your current setpoint signal. This may be set by the Smart-Trak Software or from an external analog signal.

Change Valve Operation –Automatic, Close, Purge

This function enables or overrides any setpoint command given to the Smart-Trak. At start-up, the box will show:

Automatic

In this normal operating position, the valve is ready to control flow when it receives a setpoint from some source. Using this box, you may set the valve to open well beyond its normal maximum position (“Purge”) or force the valve to remain shut regardless of setpoint (“Closed”). Use the pull down menu to make this change. Choose “purge” to fully open the valve regardless of the given setpoint or choose “closed” to override any setpoint command and close the valve.



CAUTION: Do not activate the valve state pull-down menus unless you are ready to make this change. Once in the pull-down menu, if you click on one of the selections, the valve operation will change immediately. Remember that the Max-Trak is not a positive shut-off device.

Change Gas (Dial-A-Gas™)



This box will display the current gas selection. If you wish to change the gas used in the instrument, activate the pull-down menu. The 10 gases programmed into the memory of your Max-Trak will be displayed. Choose the correct gas for your current application and click. The new gas selection will appear in the box. Within a few seconds, the new gas selection will also appear in the yellow Mass Flow and Full Scale boxes and the values of the mass flow, setpoint and the full scale will be adjusted for this new gas. This is normal. In some cases, where the thermal properties of one gas are very similar to another, these values may not change very much.

Change Units

This box will show the current engineering units. Should you wish to change the engineering units, use the pull-down menu. Make your selection, noting that each engineering unit is available with 3 different time constants: seconds, minutes and hours. Choose the combination of units and time constants you desire, then click. The box will display your new selection. Within a few seconds, the units will change in the Mass Flow, Setpoint, and Full Scale boxes and the numerical values will be adjusted into the new units. The maximum numerical value of this feature is 9999. If, after making a new selection, any of the yellow boxes show “9999,” you have exceeded the range of your instrument. Make another selection of units or time constants until the display shows a value other than “9999.”



CAUTION: It is not recommended that you operate this instrument with the display showing “9999.”

Change Setpoint Source (Mass flow controllers only)

In this box you can re-configure the location of the setpoint for the Max-Trak controller. If you intend to supply the setpoint command signal from your computer using the RS-232 link or from the Pilot Module, the display in this box should read:

Pilot Module/RS-232

If, instead of using the RS-232 link or the Pilot Module, you prefer to supply an analog setpoint signal to the Smart-Trak, activate the pull-down menu. You will see 5 options:

Pilot Module/RS-232

0-5 VDC

0-10 VDC

1-5 VDC

4-20 mA

Make your selection carefully and click. Your selection will appear in the box and, after a few seconds, it will also appear in the yellow setpoint box.



CAUTION: If you change the source of the setpoint to one of the analog values, you will not be able to control your Smart-Trak mass flow controller with your computer or because it will be looking for an analog setpoint.

Change Output Signal

This box will show the two analog output signals currently selected for your instrument. To re-configure the analog output signals, use the pull-down menu to display 6 possible combinations. Notice that there is always one current and one voltage selection. Choose 0-5 VDC, 1-5 VDC or 0-10 VDC, in addition to 4-20 mA and left click. Your selection will appear in the box. The Smart-Trak will adjust the analog output voltage signal per your instruction.

Change Full Scale

The instrument will display its current full-scale value. If your instrument is new or this value has never been modified, the value displayed will be 100% of the maximum flow rate your Smart-Trak can measure or control without factory re-calibration. It is not a percentage of the modified full-scale value. The factory full-scale value is clearly indicated below the white Password box on the right side of your screen:

Max Full Scale XXXX

The instrument's maximum flow rate is also recorded on the data label (at the back of the instrument) and on the calibration certificate.

You may select any full-scale value between 100% and 50% of the maximum full-scale value.

If you select a new full-scale value, it will re-define the analog outputs of the instrument. The 20 mA signal and the corresponding voltage signal (5 or 10 VDC) will now represent this new full-scale value.



CAUTION: The Change Full Scale function allows you to re-range your instrument, but it is important to be aware of the limitations of this function. Here are some guidelines to remember if you choose to modify the Full Scale Value:

1. Changing the full-scale value of the instrument does not affect the accuracy of the measurement. Instrument accuracy is a percentage of the original factory full-scale value (or it is a percentage of the measured value combined with the factory full-scale value, if the high accuracy calibration option was purchased).

2. If you enter a full-scale value beyond the instrument's calibrated maximum range, the Smart-Trak software will automatically modify the full-scale to equal the factory full-scale value.
3. Below 1% of the original factory full-scale value for a meter and 2% for a controller, your Max-Trak is programmed to read zero because the error in the measurement may exceed the measurement itself.

To change the full-scale value of your device, modify one digit or erase the current value displayed and type in your desired full-scale value. When you are satisfied with your selection, press the enter key. The new full-scale value will appear in the white box. A few seconds later, the same value will appear in the yellow box in the upper half of the screen titled "Full Scale."

Change Password

Use this box to change the instrument password from the factory default to any four-digit password of your choice. The factory default password is four zero's: "0000". The box will show:

To change the Password of your device, erase the four stars and type in any four numbers of your choice. The numbers will appear in the white box. When you are satisfied with your selection, press the enter key. The Smart-Trak will ask you to confirm your new password and will display your selection. Verify that the password is correct and click on "Yes." Now, the Password has been changed.



Caution: Once you change the Password, you will not be able to enter the Lower Level without it. Be certain the new password is recorded.

Lost Passwords and General Customer Service

If you lose your password, it will be necessary to contact one of Sierra's Technical Support Centers.

USA World Headquarters Monterey, California

TOLL FREE: 800-866-0200

PHONE: 831-373-0200

FAX: 831-373-4402

EMAIL: service@sierrainstruments.com

European Sales and Service Center Egmond a/d Hoef, the Netherlands

PHONE: +31 72 5071400

FAX: +31 72 5071401

EMAIL: service@sierra-instruments.nl

Asia Sales and Service Center Shanghai, PRC

PHONE: + 8221 5879 8521

FAX: +8621 5879 8586

EMAIL: www.sierra-asia.com

OTHER USEFUL FEATURES

There are several additional features that you may utilize via the Smart-Trak Software. Across the top of the Smart-Trak Master Screen, you can see these options:

Comm Port

Read Parameters

To use these functions, simply place the mouse pointer onto the name of the feature you wish and left click.

Comm Port

To change the communication port for the Max-Trak, click on this feature. Use the pull down menu to choose the Comm Port that your Max-Trak's serial connector is plugged into. Remember that the software asks you to confirm your Comm Port every time you re-start. This feature is designed for situations when you have multiple Comm Ports available and you wish to move the Max-Trak from one to another or you are controlling more than one Max-Trak instrument at one time.

Read Controller Parameters

Use this function if you believe your computer and your Max-Trak instrument may have stopped communicating. It is essentially a re-boot command for the Max-Trak microprocessor. When you switch Comm Ports, it is recommended that you use this function. If your computer requires a re-boot and you do not unplug your Max-Trak, the communication link will be broken. Use this function to re-establish communication. If at any time, the instrument does not appear to be sending correct information to the Smart-Trak software, try this command to ensure communication.



CAUTION: The Max-Trak will not return to its original factory settings when you activate this feature. It will return to the last set of instructions it accepted just before this function is activated. If you desire to return the instrument to the original factory settings, you must re-enter these parameters as recorded on the data label or on the Calibration Certificate.

CHAPTER 5: MAX-TRAK CONFIGURATION WITH REMOTE PILOT MODULE



Max-Trak may re-configured on site with the Remote Pilot Module accessory. You may also choose to re-configure your instrument on site with the Smart-Trak software and your computer. See Chapter 4 for details.



CAUTION—If the Remote Pilot Module will be used to configure a Max-Trak instrument that normally operates via RS-232 digital communication, the RS-232 must be disabled during the configuration. Only ONE form of digital communication may be used at any time. If you attempt to use the Remote Pilot Module AND the RS-232 communication simultaneously, DAMAGE TO THE INSTRUMENT CAN RESULT.

Introduction to Pilot Module Features and Capabilities

The optional Pilot Module functions as both display and a control unit for configuring your Max-Trak instrument. It is connected to the Max-Trak via a detachable cable 10 feet (3 meters) in length.

To activate the Remote Pilot Module, you must first remove the top cover of the instrument. See Chapter 2 for details on Opening the Max Trak Instrument (page 2-5).

Under the terminal strip PCA, you will find an RJ-45 cable that is about 3 inches long (75 mm). Carefully pull this out from the storage location so that it extends outside the enclosure. Place the connector into one of the two matching jacks on the Remote Pilot Module. For your convenience, Sierra has provided two jacks—one on the back and one on the bottom of the Remote Pilot Module. You may use whichever jack is most convenient for your application as they both have identical functions. In addition, Sierra provides a 10 foot cable and female-to-female adapter so that you may configure your Max-Trak instrument from a more comfortable distance.

When your Remote Pilot Module is first connected, it will display:

Version
1.10
Waiting for Meter

After 5 seconds, the LCD display will indicate that communication between the Pilot Module and the Max-Trak microprocessor has been established by showing:

Version
1.10
Waiting for Meter
Read Parameters

Assuming no gas is flowing, after another few seconds the display will read:

Mass Flow
0.000 sl/m
Air

Note: If gas is flowing the Pilot Module will immediately display the gas mass flow rate on the LCD panel. If you have chosen alternate units or another gas, the display will show the selected units instead of the above.

The optional Remote Pilot Module includes a large LCD graphic display screen and six buttons. The LCD will show a variety of information and the buttons can be used to view and modify this information. The convenient buttons are:

Left arrow

Right arrow

Up arrow

Down arrow

Enter button

Escape button

These are shown in the photo below:

Pilot Module Push Button Functions

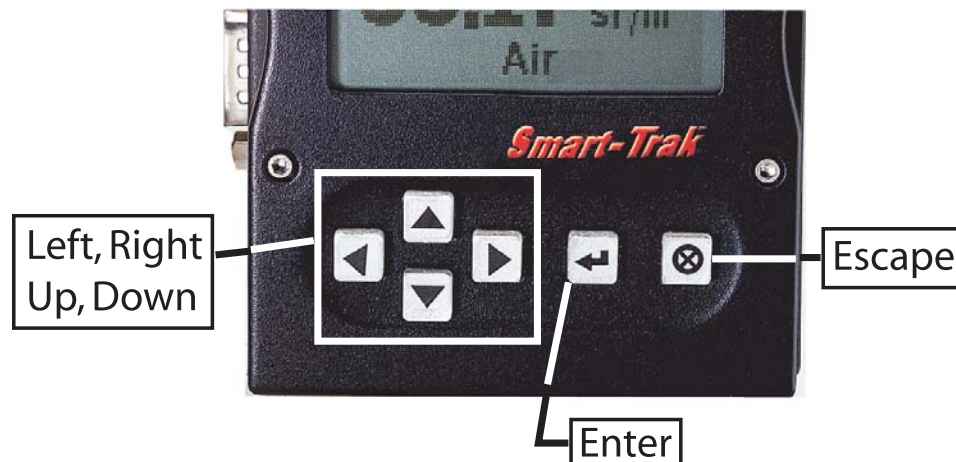

USING THE PILOT MODULE MENUS & USER INTERFACE

The features of the Pilot Module can be considered in three groups:

- 1 **Upper Level Screens:** display information (no password is required to view this information). These include:
 - ❖ Mass flow rate
 - ❖ Gas (10 options pre-programmed)
 - ❖ Engineering units (mass per unit time)
 - ❖ Current Setpoint with units
 - ❖ Source of Setpoint (analog or digital and type)
 - ❖ Valve operation mode (normal, valve close or purge)
 - ❖ Current meter full scale value with units (user selectable)

- 2 **Lower Level Screens:** permit changes to instrument operation. They are password protected. These include:
 - ❖ Setpoint value
 - ❖ Engineering units
 - ❖ Gas
 - ❖ Valve operation
 - ❖ Source of the setpoint signal
 - ❖ Form of the output signals
 - ❖ Full scale of the instrument
 - ❖ Password

- 3 **Maintenance Features:**
 - ❖ Re-boot the Max-Trak microprocessor

MAP OF THE PILOT MODULE MENUS & USER INTERFACE

The Pilot Module user interface is presented below in a graphical format. Once you have some familiarity with the user interface, you may find you want to make a copy of this and keep it with the instrument for reference. You can find a larger version of this Flow Chart in Appendix C.

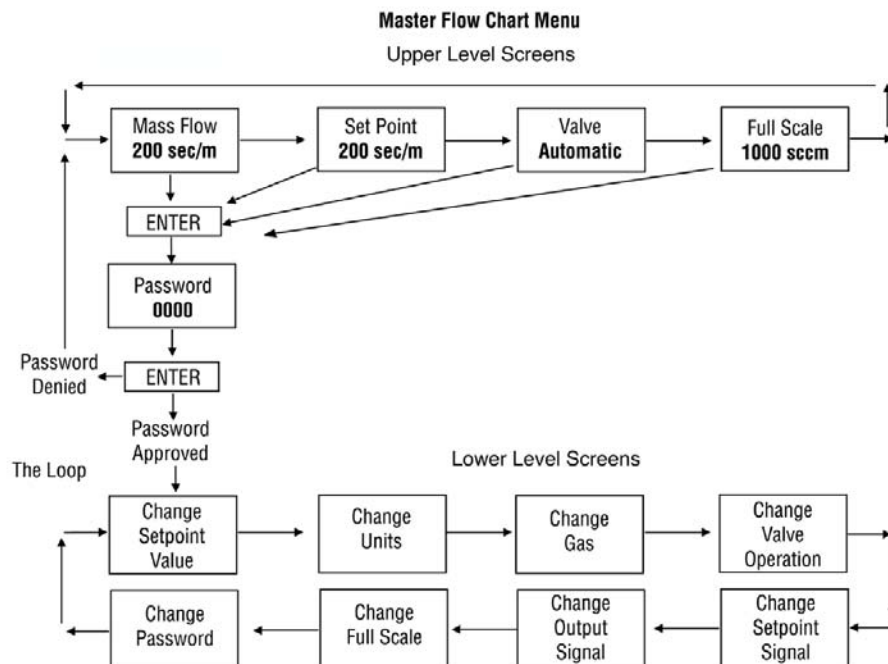

Note: If you press the escape key at any time, you will immediately return to the Mass Flow screen in the Upper Level.

UPPER LEVEL SCREENS (DISPLAY CURRENT CONFIGURATION)

The four **Upper Level Screens** display a variety of information. You are able to move between the screens by pressing the left or right arrows. No password is required for the Upper Level Screens.

Mass Flow Screen

When the instrument is powered up, or whenever the escape button is pressed, it always returns to the Mass Flow Screen. This screen displays the mass flow rate, the engineering units and your gas choice. It looks something like this:

Mass Flow
0.000 sl/m
Air

Setpoint Screen (mass flow controllers only)

Pushing the right arrow takes you to the Setpoint Screen. The Setpoint Screen displays the current setpoint given to the controller, the engineering units and the source of the setpoint signal.

The source of the setpoint can be:

1. Pilot Module/RS-232
2. 4-20 mA
3. 1-5 Vdc
4. 0-5 Vdc
5. 0-10 Vdc

The display will look something like this:

Setpoint
10.00 sl/m
4-20 mA

If this screen does not show “Pilot Module/RS-232” at the bottom, you will not be able to give the controller a setpoint command from the Pilot Module because the instrument is configured for an analog setpoint. See section below titled “Change Setpoint Source Screen” to change the source of the setpoint signal.

Valve Position Screen (Mass Flow Controllers only)

Pushing the right arrow again takes you to the Valve Position Screen, if you have a Mass Flow Controller. This screen will display the current state of the Max-Trak valve.

The state of the valve can be:

1. Closed (Remember that the Max-Trak is not a positive shut-off device).
2. Purge--Maximum Open (can be from 120 to 200% of the calibrated full scale)
3. Automatic (the normal position, where the controller responds to a setpoint signal)

WARNING: The flow rate in Purge is much greater than the calibrated full scale value and as a result can be dangerous. Exercise caution before activating Purge.



For normal operation of the flow controller, this screen should display:

Valve
Automatic
Normal

If this is visible, the instrument will automatically control flow as soon as a setpoint is given to it. If this screen displays Closed or Purge, the instrument has been placed into an override position and it will not respond to any setpoint signal. The valve state may be changed using the “Change Valve Operation” as described on page 5-16.

Full Scale Screen

Pressing the right arrow again takes you to the Full Scale Screen. This screen displays the current full scale value of the instrument with engineering units. It also displays the gas. Note that this is not necessarily the factory calibrated full scale value. The screen will display:

Full Scale
10.00 sl/m
Nitrogen

To change the full scale value, see the section below titled “Change Full Scale Screen.” Pressing the right arrow again takes you back to the Mass Flow Screen.

PASSWORD SCREEN

Your instrument is password protected so that unauthorized personnel will be unable to change the operating parameters of Max-Trak. To enter the Lower Level Screens at any time you must first supply the correct password.

Password

By pressing the “enter” key from any of the Upper Level Screens you will come to the Password Screen. (If you do not know if you are in an Upper Level Screen, press escape and you always automatically go to the Mass Flow Screen in the Upper Level) The display will show:

Enter Password

0000

The first digit will blink. At this point, you must enter the correct password to gain access to the Lower Level Screens.

- ✓ **If the instrument is being operated for the first time or if no password has ever been set on the instrument:** You can use the factory default password. The factory default password is “0000.” To proceed to the Lower Level Screens by using the factory default password, simply press the “enter” key a second time. If you want rapid access to permit regular changes to your instrument and you do not desire a password, this is the fastest way to enter the lower level.
- ✓ **If You Have a Password:** If you have already set a password, enter it now. To enter the password, push the up arrow to increase the blinking digit or the down arrow to decrease the blinking digit. To move to the next digit, press the left or right arrow and repeat the process. When you have selected your four digit password, press the enter key.
- ✓ **If You Want to Set a New Password:** If you want to change the password, you must first get to the Lower Level Screens. Proceed by entering your known password or if no password has ever been set on the instrument, use the factory default password. Follow the instruc-

tions in the “Change Password Screen” section found later in this chapter.

If the password you have entered is correct, you will enter the Lower Level at the Change Setpoint Value Screen.

If the password is not correct, the display will show:

Access Denied
Press any button
To continue

When you press any button, you will return to the Mass Flow Screen in the Upper Level. Press the “enter” key to try again.

LOST PASSWORDS & GENERAL CUSTOMER SERVICE: If you lose your password, it will be necessary to contact one of Sierra’s Technical Support Centers.

Email Customer Service: service@sierrainstruments.com

FACTORY USA Customer Service:

TOLL FREE: 800-866-0200

PHONE: 831-373-0200

FAX: 831-373-4402

EMAIL: service@sierrainstruments.com

European Customer Service:

PHONE: +31 72 5071400

FAX: +31 72 5071401

EMAIL: service@sierra-instruments.nl

Asia Customer Service:

PHONE: + 8621 5879 8521

FAX: +8621 5879 8586

EMAIL: www.sierra-asia.com



LOWER LEVEL SCREENS (CHANGING CONFIGURATION)

The eight Lower Level Screens are at the heart of your Max-Trak instrument. It is here that you can re-configure many instrument parameters including our Dial-A-Gas technology. It is possible to make multiple changes on different Lower Level Screens before exiting.

For example, you could change between one of the ten pre-programmed gases, change the engineering units, and change the setpoint all in one visit to the Lower Level Screens. The Max-Trak will make each adjustment as you complete it. At any time, you may press the escape button to return to the Upper Level.

Change Setpoint Value Screen

This screen is the entry point to the Lower Level. As soon as a correct password is entered, you will arrive here. If you are already in the Lower Level Screens, push the right or left arrow until you reach the Change Setpoint Value screen.

If your instrument is configured for an analog setpoint source (mA or Vdc), the display will show:

**Change Setpoint
Must be in
Pilot Mode**

This is a reminder that your Max-Trak instrument is configured for the use of an analog set point (command signal). If this is correct, push the right arrow to move to the next screen. If you wish to control the instrument from a digital source such as RS-232 communication, proceed to the Change Setpoint Source Screen section below to re-configure.

If your instrument is currently configured for a digital setpoint source (RS-232 or Remote Pilot Module), the display will show:

**Change Setpoint
Value
00.00 sl/m**

This is the position where you can change the setpoint value of the mass flow controller digitally if you choose. To make a change to the displayed value, press the enter key. The first number in the display will blink. Use the up and down arrows to change the value of this digit or the left and right arrows to move to another digit. For example, if you wish to enter a setpoint of 12.5 sl/m, push the “up” arrow once when the first digit is blinking. You will see:

**Change Setpoint
Value
10.00 sl/m**

Next, press the “right” arrow so that the second digit blinks. Push the up arrow twice. You will now see:

**Change Setpoint
Value
12.00 sl/m**

Press the right arrow again. The first digit after the decimal point will now blink. Press the up arrow 5 times until you see:

**Change Setpoint
Value
12.50 sl/m**

Now that you have made your selection, press the enter key. The display from our example will show:

Setpoint
Change to
12.50 sl/m
No

The “No” will be blinking. In this screen you must confirm that the new setpoint is what you desire. If it is not correct, press enter and return to the Change Setpoint Value screen. If the displayed setpoint is correct, press any arrow key. The display will then read:

Setpoint
Change to
12.50 sl/m
Yes

Now, the “Yes” will blink. Press the enter key to accept your changes and to immediately adjust the setpoint to the Mass Flow Controller.

If you are finished or wish to observe the changes you have made on the LCD panel, press the escape key to return to the Upper Level Mass Flow Screen.

If you prefer to make additional changes, use the left and right arrow keys to move to other Lower Level Screens.



Caution!

The Max-Trak will not allow you to enter a setpoint greater than the current full scale value set on the instrument.

Note: If you enter a Setpoint that exceeds the full scale value (displayed in the “Full Scale” screen in the Upper Level), the Max-Trak will automatically modify this value to equal the current full scale value. For example, if the current full scale value of your instrument is 10 slpm and you have entered a setpoint of 15 slpm, the Max-Trak will modify your setpoint to 10 slpm when you implement the change. The Setpoint Value screen will show 10 slpm, not 15 slpm.

Change Units Screen

If you are already in the Lower Level Screens, push the right or left arrow until you reach the Change Units screen. To get to this screen at any time, Press Escape—Press Enter—type password and Press Enter. Then, press the Right or Left arrow until you reach the Change Units Screen.

The display will show:

Change Units

sl/m

If you wish to change the engineering units, press the enter button at this point. The “mass units” will begin to blink. Use the up or down arrows to select an alternate unit. You can choose from the following mass units:

sl
NL
g
kg
lb
scc
Ncc
SCF
NM³
SM³

When you are satisfied, push the left or right arrow. You will now see the “time unit” blink. Use the up or down arrows to select your choice of time units. You can choose from the following time units:

m (minutes)
H (hours)
S (seconds)

When you are finished, press the enter button again. You will see:

Units

Change to

XXX/x

No

And the “No” will blink. If you do not want to make the displayed change, press enter. You will return to the Change Units screen. If you

want to make the displayed change, press any arrow. The display will change to:

Units
Change to
XXX/x
Yes

And the “Yes” will blink. You may now press the enter key to implement your changes. You can make additional changes by using the left and right arrow keys to move to other Lower Level Screens. You may also choose to press the escape key to return to the Upper Level Screens and to observe your change.]

Change Gas Screen (Dial-A-Gas)

If you are already in the Lower Level Screens, push the right or left arrow until you reach the Change Gas screen. To get to this screen at any time: Press Escape—Press Enter—type password and Press Enter. Then, press the Right or Left arrow until you reach this screen. The display will show:



Change Gas
Nitrogen

If you wish to change the gas used in the instrument, press enter. The name of the gas will blink. Use the up and down arrows to make your selection. When you reach the desired gas, press enter. You will see:

Gas
Change to
XXXX
No

The “No” will blink. If you do not want to make the displayed change, press enter. You will return to the Change Units screen. If you want to make the displayed change, press any arrow. The display will change to:

Gas
Change to
XXXX
Yes

Now, the “Yes” will blink. You must now press the enter key to implement your changes. You can make additional changes by using the left

and right arrow keys to move to other Lower Level Screens. You may also choose to press the escape key to return to the Upper Level Screens and to observe your change.

Note: your instrument comes with 10 pre-programmed standard gases. These are listed in the Specifications in Appendix **B**. Max-Trak may be ordered with alternate gases programmed. If your device was so ordered, you may choose from these gases instead. You may see the 10 gases programmed in your instrument by using this screen and simply scrolling up or down.

Change Valve Operation-Close, Purge

If you are already in the Lower Level Screens, push the right or left arrow until you reach the Change Valve Operation screen. To get to this screen at any time: Press Escape—Press Enter—enter password and Press Enter. Then, press the Right or Left arrow until you reach this screen. The display will show:



Caution!

The Max-Trak valve is not a positive shut-off device.

**Change Valve
Operation
Automatic**

From this screen you may set the valve to open all the way (“Purge”), force the valve to remain closed until further changes are made (“Valve Closed”) or set the valve to control flow when it receives a setpoint from some source (“Automatic”). To make a change to the valve operation, press the enter key. Use the up and down arrows to make your selection. When you are satisfied, press the enter key again. You will see:

**Valve State
Change to
XXXXX**

No

The “No” will blink. If you do not want to make the displayed change, press enter. You will return to the Change Valve Operation screen. If you want to make the displayed change, press any arrow. The display will change to:

Valve State
Change to
XXXXX
Yes

Now, the “Yes” will blink. You must now press the enter key to implement your changes. You can make additional changes by using the left and right arrow keys to move to other Lower Level Screens. You may also choose to press the escape key to return to the Upper Level Screens.

Note: The valve will move to the desired position immediately when you press the enter key.

IMPORTANT SAFETY NOTES ABOUT PURGING



WARNING: When toxic or corrosive gases are used, purge unit thoroughly with inert dry gas before disconnecting from the gas line to prevent personnel from being injured when coming in contact with the instrument. Chapter 3 discusses how to purge your instrument.



WARNING: The flow rate in Purge is much greater than the calibrated full scale value and as a result can be dangerous.

Change Setpoint Source Screen (mass flow controllers only)

If you are already in the Lower Level Screens, push the right or left arrow until you reach the Change Setpoint Source screen. To get to this screen at any time: Press Escape—Press Enter—enter password and Press Enter. Then, press the Right or Left arrow until you reach this screen.

The Change Setpoint Source screen allows you to re-configure the location and type of the setpoint for the Max-Trak controller. If you intend to Lower Level Screens (Changing Configuration) computer using the RS-232 link, the display must show:

Change Setpoint Source Pilot Module/RS-232

If, instead of using the Pilot Module or the RS-232 link, you prefer to supply an analog setpoint signal to the Max-Trak, press the enter button. “Pilot Module/RS-232” will begin to blink. Use the up and down arrows to make your selection from the following choices:

0-5 VDC
0-10 VDC
1-5 VDC
4-20 mA
Pilot Module/RS232

When you are satisfied, press enter. You will see:

Setpoint Source
Change to
XXXXX
No

The “No” will blink. If you do not want to make the displayed change, press enter. You will return to the Change Valve Operation screen. If you want to make the displayed change, press any arrow. The display will change to:

Setpoint Source
Change to
XXXXX
Yes

Now, the “Yes” will blink. You must now press the enter key to implement your changes. You can make additional changes by using the left and right arrow keys to move to other Lower Level Screens. You may also choose to press the escape key to return to the Upper Level Screens.



Caution: If you change the source of the setpoint to an analog value, you will not be able to control your Max-Trak mass flow controller via the Pilot Module or your computer.

Change Output Signals Screen

If you are already in the Lower Level Screens, push the right or left arrow until you reach the Change Output Signals screen. To get to this screen at any time: Press Escape—Press Enter—enter password and Press Enter. Then, press the Right or Left arrow until you reach this screen. The display will show:

Change Output Signals 0-5 VDC/4-20 mA

Here you can re-configure the analog output signals for the instrument. The Max-Trak always outputs one current signal of 4-20mA but the voltage signal may be selected using this screen. Use the up and down arrows to make your selection. You can choose between:

0-5VDC and 4-20mA
0-10VDC and 4-20mA
1-5VDC and 4-20mA

When you are finished making your selection, press enter. The screen will read:

**Output
Change to
XXXXX
No**

The “No” will blink. If you do not want to make the displayed change, press enter. You will return to the Change Output Signals screen. If you want to make the displayed change, press any arrow. The display will change to:

**Output
Change to
XXXXX
Yes**

Now, the “Yes” will blink. You must now press the enter key to implement your changes. You can make additional changes by using the left and right arrow keys to move to other Lower Level Screens. You may also choose to press the escape key to return to the Upper Level Screens.

Change Full Scale Screen

If you are already in the Lower Level Screens, push the right or left arrow until you reach the Change Full Scale screen. To get to this screen at any time: Press Escape—Press Enter—enter password and Press Enter. Then, press the Right or Left arrow until you reach this screen. The display will show:

Change Full Scale

XX.XX sl/m

Max = YY.YY

This screen allows you to re-range the outputs of your instrument. You may select any full-scale value between 100% and 50% of the displayed maximum value (this is the factory full-scale calibration value).

The new full-scale value that you select will re-define the analog outputs of the instrument. The 20 mA signal and the corresponding voltage signal (5 VDC, 1-5 VDC or 10 VDC) will now represent this new full-scale value.



Caution: Changing the full-scale value of the instrument does not affect the accuracy.

The accuracy is always $\pm 1\%$ of the original factory full-scale calibration value.



Caution: For any instrument, if a value greater than the factory full scale calibration value is entered on this screen, the Max-Trak will modify the requested value to equal the factory full scale calibration value.

If you choose to change the full-scale value, press the enter key. The first digit will blink. Use the up and down arrows to adjust the value of the digit or the left and right arrows to choose another digit. When you have completed your modification, press the enter key. The display will show:

Full Scale

Change to

XX.XX

No

The “No” will blink. If you do not want to make the displayed change, press enter. You will return to the Change Full-Scale screen. If you want to make the displayed change, press any arrow. The display will change to:

Full Scale
Change to
XX.XX
Yes

Now, the “Yes” will blink. You must now press the enter key to implement your changes. You can make additional changes by using the left and right arrow keys to move to other Lower Level Screens. You may also choose to press the escape key to return to the Upper Level Screens.

Change Password Screen

If you are already in the Lower Level Screens, push the right or left arrow until you reach the Change Password screen. To get to this screen at any time: Press Escape—Press Enter—enter password and Press Enter. Then, press the Right or Left arrow until you reach this screen.

From this screen you can change the instrument password from the factory default to any four-digit password of your choice. The display will show the factory default password of four zero's: “0000”. The display will show:

Change Password
0000

To make a change, press the enter key. The first digit will begin to blink. Use the up and down arrows to modify this digit or the left and right arrows to choose another digit. When you are satisfied, press enter. The display will show:

Password
Change to
XXXX
No

The “No” will blink. If you do not want to make the displayed change, press enter. You will return to the Change Password screen. If you want to make the displayed change, press any arrow. The display will change to:

**Password
Change to
XXXX
Yes**

Now, the “Yes” will blink. You must now press the enter key to implement your changes. You can make additional changes by using the left and right arrow keys to move to other Lower Level Screens. You may also choose to press the escape key to return to the Upper Level Screens.



Caution: Once you change the Password, you will not be able to enter the Lower Level without it. Be certain the new password is recorded.

Lost Passwords and General Customer Service

If you lose your password, it will be necessary to contact one of Sierra’s Technical Support Centers.

Email Customer Service: service@sierrainstruments.com

FACTORY USA Customer Service:

TOLL FREE: 800-866-0200

PHONE: 831-373-0200

FAX: 831-373-4402

EMAIL: service@sierrainstruments.com

European Customer Service:

PHONE: +31 72 5071400

FAX: +31 72 5071401

EMAIL: service@sierra-instruments.nl

Asia Customer Service:

PHONE: + 8221 5879 8521

FAX: +8621 5879 8586

EMAIL: www.sierra-asia.com

MAINTENANCE FUNCTIONS

Re-boot the Microprocessor

Should you ever need to reboot the Max-Trak microprocessor, press the left arrow, the down arrow, the enter key and the escape button simultaneously. The Max-Trak will re-initialize its microprocessor.

CHAPTER 6: TECHNICAL SUPPORT & SERVICE

If you encounter any problem with your instrument, review the configuration information for each step of the installation, operation, and set up procedures as explained in this manual. Verify that your settings and adjustments are consistent with factory recommendations.

If the problem persists, Sierra is eager to help you. You may contact us at any of the following Technical Support Centers. It may also help to call your

Sierra Sales Agent, who is also well trained in the operation and installation of the product.

IMPORTANT: When contacting Technical Support, make sure you have included the following information:

- The model number, flow range, serial number and Sierra order number (all marked on the instrument data label).
- The problem you are encountering and any corrective action taken.
- Application information (gas, pressure, temperature, pipe and fitting configuration).

SIERRA CUSTOMER SERVICE LOCATIONS:

USA World Headquarters

Monterey, California

TOLL FREE: 800-866-0200

PHONE: 831-373-0200

FAX: 831-373-4402

EMAIL: service@sierrainstruments.com

European Sales and Service Center

Egmond a/d Hoef, the Netherlands

PHONE: +31 72 5071400

FAX: +31 72 5071401

EMAIL: service@sierra-instruments.nl

Asia Sales and Service Center

Shanghai, Peoples Republic of China

PHONE: + 8221 5879 8521

FAX: +8621 5879 8586

EMAIL: www.sierra-asia.com

Sierra Websites

Sierra Instruments, Inc. (USA Headquarters): **www.sierrainstruments.com**

Sierra Instruments b.v. (Europe): **www.sierrainstruments.nl**

Sierra Asia Instruments (China): **www.sierra-asia.com**

Smart-Trak Website: **www.sierrasmarttrak.com**

Vortex Multivariable Mass Flow Meter Website: **www.innovamass.com**

Engine Emissions Testing Systems Website: **www.sierraemissions.com**

RETURNING EQUIPMENT TO THE FACTORY

Factory Calibration—All Models

Sierra Instruments maintains a fully-equipped calibration laboratory. All measuring and test equipment used in the calibration of Sierra transducers are traceable to NIST Standards. Sierra is ISO-9001 registered and conforms to the requirements of ANSI/NCSL-Z540 and ISO/IEC Guide 25.

Instructions for Returning Your Instrument for Service

The following information will help you return your instrument to Sierra Instruments' Factory Service Center and will ensure that your order is processed promptly. Prices may vary depending on the flow range, type of gas and operating pressure of your unit. To request detailed pricing contact your local Sierra Instruments distributor or contact one of our offices directly. Our expedite fees are: three-day turnaround 25%, two-day turnaround 40%.

Please follow these easy steps to return your instrument for factory service:

1. Obtain a Return Materials Authorization (RMA) number from Sierra Instruments. You may obtain this from the factory by calling (800) 866 0200 between 8:00 a.m. and 5:00 p.m. PST Monday through Friday. You may also obtain this number via e-mail by contacting service@sierrainstruments.com.
2. Once you have obtained an RMA number, complete the form. If you require service beyond calibration, but do not know which service(s) will be required, describe the symptoms as accurately as possible on the RMA form. Submit electronically or by fax to (831) 373-2414.
3. Pack your instrument carefully. Use the original packaging and foam or bubble wrap (packing peanuts NOT recommended) and include a copy of the RMA form (complete with Sierra supplied RMA number) with the unit(s).
4. Ship the unit(s) to the following address:



Caution!

Always fully neutralize any toxic gas trapped inside the instrument before removing it from the gas line.

RETURN ADDRESS:

**Sierra Instruments, Inc.
Attention: Factory Service Center
5 Harris Court, Building L
Monterey, CA 93940 USA**

IMPORTANT SAFETY NOTE ABOUT PURGING

WARNING: When toxic or corrosive gases are used, purge unit thoroughly with inert dry gas before disconnecting from the gas line to prevent personnel from being injured when coming in contact with the instrument.



WARNING: If an instrument used with a toxic or corrosive gas is returned to the factory, a Material Safety Data Sheet (MSDS) must be enclosed & attached to the outside of the box to alert Sierra personnel of the potential hazard. Also, make sure the inlet & outlet are solidly plugged off.

Appendix A: Gas Tables

Max-Trak Pre-programmed Gases: Dial-A-Gas

The following gases have been programmed into the Max-Trak instrument in this order. If you are using one of these gases, you may use the Dial-A-Gas feature in either the Software Package or the Remote Pilot Module and the instrument will adjust the outputs automatically.



1. Air
2. Argon
3. CO₂
4. CO
5. Helium
6. Hydrogen
7. Methane
8. Nitrogen
9. Nitrous Oxide
10. Oxygen

K-Factor Calculations— Using Max-Trak with Other Gases

If you will be using Max-Trak with a gas not on this list, you may use the tables below. They provide K-factors and thermodynamic properties of gases commonly used with mass flow meters and controllers. This is particularly useful if the actual gas is not a common gas or if it is toxic, flammable, corrosive, etc. The tables can also be used to interpret the reading of a flow meter or flow controller that has been calibrated with a gas other than the actual gas.

Before applying the tables, set the instrument for Air. Then, the following fundamental relationship may be used:

$$Q_1/Q_N = K_1/K_N$$

Where:

Q = The volumetric flow rate of the gas referenced to standard conditions of 0°C and 760 mm Hg (sccm or slm),

K = The K-factor from the following tables, referenced to Air

()₁ = Refers to the “actual” gas, and

()_N = Refers to the “reference” gas, Air in this case.

Gas Tables and K-factors

Actual Gas	Chemical Symbol	K-factor Relative to Air	Cp (Cal/g)	Density (g/l) @ 70°F	Density (g/l) @ 0°C	Elastomers* O-ring	Valve Seat
Acetylene	C ₂ H ₂	.581	.4036	1.079	1.162		
Air		1.000	.240	1.200	1.293		
Allene (Propadiene)	C ₃ H ₄	.431	.352	1.659	1.787		KR
Ammonia	NH ₃	.732	.492	.706	.760	NEO	KR/NEO
Argon	Ar	1.398	.1244	1.655	1.782		
Arsine	AsH ₃	.671	.1167	3.229	3.478		KR
Boron Trichloride	BCl ₃	.411	.1279	4.852	5.227	800 Series Recommended	
Boron Trifluoride	BF ₃	.511	.1778	2.808	3.025		KR
Boron Tribromide	Br ₃	.381	.0647	10.378	11.18		KR
Bromine	Br ₂	.812	.0539	6.619	7.130		
Bromine Pentafluoride	BrF ₅	.261	.1369	7.244	7.803		KR
Bromine Trifluoride	BrF ₃	.381	.1161	5.670	6.108		KR
Bromotrifluoromethane (Freon-13 B1)	CBrF ₃	.371	.1113	6.168	6.644		
1,3-Butadiene	C ₄ H ₆	.321	.3514	2.240	2.413		
Butane	C ₄ H ₁₀	.261	.4007	2.407	2.593		
1-Butane	C ₄ H ₈	.301	.3648	2.324	2.503	NEO	KR
2-Butane	C ₄ H ₈ CIS	.325	.336	2.324	2.503	NEO	KR
2-Butane	C ₄ H ₈ TRANS	.292	.374	2.324	2.503		
Carbon Dioxide	CO ₂	.737	.2016	1.835	1.964		
Carbon Disulfide	CS ₂	.601	.1428	3.153	3.397		
Carbon Monoxide	CO	1.002	.2488	1.160	1.250		
Carbon Tetrachloride	CCl ₄	.311	.1655	6.368	6.860		KR
Carbon Tetrafluoride (Freon-14)	CF ₄	.421	.1654	3.645	3.926		
Carbonyl Fluoride	COF ₂	.541	.1710	2.734	2.945		
Carbonyl Sulfide	COS	.661	.1651	2.488	2.680		
Chlorine	CL ₂	.862	.114	2.936	3.163	800 Series Recommended	
Chlorine Trifluoride	ClF ₃	.401	.1650	3.829	4.125		KR
Chlorodifluoromethane (Freon-22)	CHClF ₂	.461	.1544	3.581	3.858		KR
Chloroform	CHCl ₃	.391	.1309	4.944	5.326		KR
Chloropentafluoroethane (Freon-115)	C ₂ ClF ₅	.241	.164	6.398	6.892		KR
Chlorotrifluoromethane (Freon-13)	CClF ₃	.381	.153	4.326	4.660		KR
Cyanogen	C ₂ N ₂	.611	.2613	2.156	2.322		KR
Cyanogen Chloride	CICN	.611	.1739	2.545	2.742		
Cyclopropane	C ₃ H ₅	.461	.3177	1.742	1.877		KR
Deuterium	D ₂	1.002	.1722	1.670	1.799		
Diborane	B ₂ H ₆	.441	.508	1.147	1.235		KR
Dibromodifluoromethane	CBr ₂ F ₂	.190	.15	8.691	9.362		KR
Dibromomethane		.471	.075	7.204	7.76		KR
Dichlorodifluoromethane (Freon-12)	CCl ₂ F ₂	.351	.1432	5.008	5.395		KR
Dichlorofluoromethane (Freon-21)	CHCl ₂ F	.421	.140	4.597	4.952		KR

- If no O-ring material is specified then O-ring to be used is Viton. NEO is neoprene or equivalent. KR is DuPont Kalrez or equivalent. Valve Seat applies only to controllers.

Chemical	K-factor	Cp	Density	Density	Elastomers*
----------	----------	----	---------	---------	-------------

Actual Gas	Symbol	Relative Air	(Cal/g)	(g/l) @ 70°F	(g/l) @ 0°C	O-ring	Valve Seat
Dichloromethylsilane	(CH ₃) ₂ SiCl ₂	.251	.1882	5.345	5.758		KR
Dichlorosilane	SiH ₂ Cl ₂	.401	.150	4.183	4.506		KR
Dichlorotetrafluoroethane (Freon-114)	C ₂ Cl ₂ F ₄	.220	.1604	7.079	7.626		KR
1,1-Difluoroethylene (Freon-1132A)	C ₂ H ₂ F ₂	.185	.224	2.652	2.857		KR
Dimethylamine	(CH ₃) ₂ NH	.371	.366	1.867	2.011		KR
Dimethyl Ether	(CH ₃) ₂ O	.391	.3414	1.908	2.055		KR
2,2-Dimethylpropane	C ₃ H ₁₂	.220	.3914	2.988	3.219		KR
Ethane	C ₂ H ₆	.501	.4097	1.246	1.342		
Ethanol	C ₂ H ₆ O	.391	.3395	1.908	2.055		KR
EthylAcetylene	C ₄ H ₆	.321	.3513	2.240	2.413		KR
Ethyl Chloride	C ₂ H ₅ Cl	.391	.244	2.673	2.879		KR
Ethylene	C ₂ H ₄	.601	~.358	1.161	1.251		
Ethylene Oxide	C ₂ H ₄ O	.521	.268	1.824	1.965	800 Series Recommended	
Fluorine	F ₂	.982	.1873	1.574	1.695	800 Series Recommended	
Fluoroform (Freon-23)	CHF ₃	.501	.176	2.903	3.127		KR
Freon-11	CCl ₃ F	.331	.1357	5.690	6.129		KR
Freon-12	CCl ₂ F ₂	.351	.1432	5.008	5.395		KR
Freon-13	CClF ₃	.381	.153	4.326	4.660		KR
Freon-13	B1 CFrF ₃	.371	.1113	6.168	6.644		KR
Freon-14	CF ₄	.421	.1654	3.645	3.926		
Freon-21	CHCl ₂ F	.421	.140	4.597	4.952		KR
Freon-22	CHClF ₂	.461	.1544	3.581	3.858		KR
Freon-113	CCl ₂ FCClF ₂	.200	.161	7.761	8.360		KR
Freon-114	C ₂ Cl ₂ F ₄	.220	.160	7.079	7.626		KR
Freon-115	C ₂ ClF ₅	.241	.164	6398	6.892		KR
Freon-C318	C ₄ F ₈	.170	.185	7.795	8.397	NEO	NEO
Germane	GeH ₄	.571	.1404	3.173	3.418		
Germanium Tetrachloride	GeCl ₄	.271	.1071	8.879	9.565		KR
Helium	He	1.399	1.241	.164	.1786		
Hexafluoroethane (Freon-116)	C ₂ F ₆	.241	.1834	5.716	6.157		KR
Hexane	C ₆ H ₁₄	.180	.3968	3.569	3.845		KR
Hydrogen	H ₂	1.001	3.419	.083	.0899		
Hydrogen Bromide	HBr	1.002	.0861	3.351	3.610		KR
Hydrogen Chloride	HCl	1.002	.1912	1.510	1.627	800 Series Recommended	
Hydrogen Cyanide	HCN	1.072	.3171	1.120	1.206		KR
Hydrogen Fluoride	HF	1.002	.3479	.829	.893	800 Series Recommended	
Hydrogen Iodide	HI	1.002	.0545	5.298	5.707		KR
Hydrogen Selenide	H ₂ Se	.792	.1025	3.354	3.613		KR
Hydrogen Sulfide	H ₂ S	.802	.2397	1.411	1.520	NEO	KR
Iodine Pentafluoride	IF ₅	.251	.1108	9.190	9.90		KR
Isobutane	CH(CH ₃) ₃	.271	.3872	3.335	2.593		KR
Isobutylene	C ₄ H ₈	.291	.3701	2.324	2.503		KR
Krypton	Kr	1.456	.0593	3.471	3.739		
Methane	CH ₄	.754	.5328	.665	.715		
Methanol	CH ₃ OH	.581	.3274	1.327	1.429		
Methyl Acetylene	C ₃ H ₄	.431	.3547	1.659	1.787		KR
Methyl Bromide	CH ₂ Br	.581	.1106	3.932	4.236		
Methyl Chloride	CH ₃ Cl	.193	2.253	2.092			KR
Methyl Fluoride	CH ₃ F	.681	.3221	1.409	1.518		KR

- If no O-ring material is specified then O-ring to be used is Viton. NEO is neoprene or equivalent. KR is DuPont Kalrez or equivalent. Valve Seat applies only to controllers.

Chemical	K-factor	Cp	Density	Density	Elastomers*
----------	----------	----	---------	---------	-------------

Actual Gas	Symbol	Relative Air	(Cal/g)	(g/l) @ 70°F	(g/l) @ 0°C	O-ring	Valve Seat
Methyl Mercaptan	CH ₃ SH	.521	.2459	1.992	2.146		KR
Methyl Trichlorosilane	(CH ₃) SiCl ₃	.251	.164	6.191	6.669		KR
Molybdenum Hexafluoride	MoF ₆	.210	.1373	8.695	9.366		KR
Monoethylamine	C ₂ H ₅ NH ₂	.351	.387	1.867	2.011		KR
Monomethylamine	CH ₃ NH ₂	.511	.4343	1.287	1.386		KR
Neon	NE	1.463	.245	.836	.900		
Nitric Oxide	NO	.992	.2328	1.243	1.339		
Nitrogen	N ₂	1.002	.2485	1.161	1.25		
Nitrogen Dioxide	NO ₂	.742	.1933	1.905	2.052	800 Series Recommended	
Nitrogen Trifluoride	NF ₃	.481	.1797	2.941	3.168		KR
Nitrosyl Chloride	NOCl	.611	.1632	2.711	2.920		KR
Nitrous Oxide	N ₂ O	.716	.2088	1.836	1.964		
Octafluorocyclobutane (Freon-C318)	C ₄ F ₆	.170	.185	7.795	8.397		KR
Oxygen Difluoride	OF ₂	.631	.1917	2.234	2.406		
Oxygen	O ₂	.998	.2193	1.326	1.427		
Ozone	O ₃	.447	.3	1.990	2.144		
Pentaborane	B ₅ H ₉	.261	.38	2.614	2.816		KR
Pentane	C ₅ H ₁₂	.210	.398	2.988	3.219		KR
Perchloryl Fluoride	ClO ₃ F	.391	.1514	4.243	4.571		KR
Perfluoropropane	C ₃ F ₈	.174	.197	7.787	8.388		KR
Phosgene	COCl ₂	.441	.1394	4.101	4.418		KR
Phosphine	PH ₃	.762	.2374	1.408	1.517		KR
Phosphorous Oxychloride	POCl ₃	.361	.1324	6.352	6.843		KR
Phosphorous Pentafluoride	PF ₅	.301	.1610	5.217	5.620		KR
Phosphorous Trichloride	PCl ₃	.301	.1250	5.688	6.127		KR
Propane	C ₃ H ₈	.335	.3885	1.826	1.967		
Propylene	C ₃ H ₆	.411	.3541	1.742	1.877		
Silane	SiH ₄	.601	.3189	1.330	1.433		KR
Silicon Tetrachloride	SiCl ₄	.281	.1270	7.037	7.580		KR
Silicon Tetrafluoride	SiF ₄	.351	.1691	4.310	4.643		KR
Sulfur Hexafluoride	SF ₆	.261	.1592	6.049	6.516		
Sulfuryl Fluoride	SO ₂ F ₂	.391	.1543	4.235	4.562		KR
Teos		.090				800 Series Recommended	
Tetrafluorohydrazine	N ₂ F ₄	.321	.182	4.307	4.64		KR
Trichlorofluoromethane (Freon-11)	CCl ₃ F	.331	.1357	5.690	6.129		KR
Trichlorosilane	SiHCl ₃	.331	.1380	5.610	6.043		KR
1,1,2-Trichloro-1,2,2 Trifluoroethane (Freon-113)	CCl ₂ FCF ₂	.200	.161	7.761	8.360		KR
Trisobutyl Aluminum	(C ₄ H ₉)Al	.061	.508	8.214	8.848		KR
Titanium Tetrachloride	TiCl ₄	.271	.120	7.858	8.465		KR
Trichloro Ethylene	C ₂ HCl ₃	.321	.163	5.523	5.95		KR
Trimethylamine	(CH ₃) ₃ N	.281	.3710	2.450	2.639		KR
Tungsten Hexafluoride	WF ₆	.251	.0810	12.328	13.28	800 Series Recommended	
Uranium Hexafluoride	UF ₆	.200	.0888	14.574	15.70		KR
Vinyl Bromide	CH ₂ CHBr	.461	.1241	4.430	4.772		KR
Vinyl Chloride	CH ₂ CHCl	.481	.12054	2.588	2.788		KR
Xenon	Xe	1.443	.0378	5.438	5.858		

- If no O-ring material is specified then O-ring to be used is Viton. NEO is neoprene or equivalent. KR is DuPont Kalrez or equivalent. Valve Seat applies only to controllers

Appendix B: Product Specifications

Performance Specifications:

Accuracy

Standard Calibration: $\pm 1.0\%$ of full scale at operating conditions

High Accuracy Calibration: $\pm 0.7\%$ of reading plus 0.3% of full scale at operating conditions.

Dial-A-Gas: $\pm 1.0\%$ of full scale in all 10 gases

Repeatability

$\pm 0.2\%$ of full scale

Temperature Coefficient

$\pm 0.025\%$ of full scale per $^{\circ}\text{F}$ ($\pm 0.05\%$ of full scale per $^{\circ}\text{C}$), or better

Pressure Coefficient

$\pm 0.01\%$ of full scale per psi ($\pm 0.15\%$ of full scale per bar), or better

Response Time

300 millisecond time constant--2 seconds (typical) to within $\pm 2\%$ of final value (includes settling time)

Operating Specifications:

Gases

All clean gases including corrosives; specify when ordering. The following 10 gases make up the standard Dial-A-Gas feature. Alternate gases may be substituted at time of ordering.

GAS	Max Flow Rate Standard Flow Body	Max Flow Rate High Flow Body
Air	300	1000
Argon	435	1450
Carbon Dioxide (CO ₂)	220	740
Carbon Monoxide (CO)	302	1000
Helium	420	1454
Hydrogen	300	1000
Methane (CH ₄)	227	720
Nitrogen	300	1000
Nitrous Oxide (N ₂ O)	215	710
Oxygen	300	1000

Mass Flow Rates

Standard Size: 0-10 to 0-300 slpm full scale (special units with full scale values down to 2 slpm and up to 400 slpm are available upon request).

High Flow Size: 0-100 to 0-1000 slpm full scale

Flow ranges specified are for nitrogen at 760 mm Hg and 21°C (70°F) or for an equivalent; other engineering units are available (e.g., scfh or nm³/h)

Gas Pressure

500 psig (34 barg) maximum, burst tested to 750 psig (52 barg)

Pressure Drop in air across a Meter (psi/mbar)

Flow Rate (slpm)	Standard Size (M180M) 3/8 or 1/2 inch fittings	High Flow Size Small Bore (M180H) (std up to 500 slpm) 1/2 comp fittings	High flow Size Large Bore (M180H1, H2) (std 501-1000 slpm) 3/4 comp fittings
10	0.5 (34)	N/A	N/A
20	0.5 (34)	N/A	N/A
30	0.5 (34)	N/A	N/A
40	0.5 (34)	N/A	N/A
50	0.5 (34)	N/A	N/A
100	1.0 (68)	1.0 (68)	0.5 (34)
150	2.0 (136)	1.2 (81.6)	0.5 (34)
200	3.0 (204)	1.5 (102)	0.5 (34)
250	4.0 (272)	1.8 (122.4)	0.5 (34)
300	5.5 (374)	2 (136)	0.6 (408)
350	N/A	2.5 (170)	0.7 (476)
400	N/A	3 (204)	0.9 (612)
450	N/A	3.5 (238)	1.1 (748)
500	N/A	4 (272)	1.3 (884)
750	N/A	N/A	3.0 (204)
1000	N/A	N/A	5.0 (340)

Differential Pressure Requirement in air for Controllers (psi/mbar)

Flow Rate (slpm)	Standard Size C180M 3/8 or 1/2 inch fittings	High Flow Size Small Bore (C180H) (std up to 500 slpm)	High flow Size Large Bore (C180H1, H2) (std 501-1000 slpm)
10	N/A	N/A	N/A
20	1 (68)	N/A	N/A
30	1.2 (82)	N/A	N/A
40	1.6 (110)	N/A	N/A
50	2 (136)	N/A	N/A
100	5 (340)	1.5 (102)	1.0 (68)
150	10 (680)	2 (136)	1.0 (68)
200	15 (1020)	4.5 (306)	1.0 (68)
250	20 (1360)	5.5 (374)	1.5 (102)
300	25 (1700)	6.5 (442)	2.0 (136)
350	N/A	8.5 (578)	3.0 (204)
400	N/A	10.5 (714)	4.0 (272)
450	N/A	13 (884)	5.0 (340)
500	N/A	15 (1020)	6.0 (408)
750	N/A	N/A	15 (1020)
1000	N/A	N/A	20 (1360)

Note: Pressures measured at 21degrees C, with outlet at 1 atm. Controllers are adjusted at the factory for customer specified pressure drop

Gas & Ambient Temperature

Gas: 32 to 122°F (0 to 50°C)

Ambient: -5 to 122°F (-20 to 50°C)

Leak Integrity

5 X 10⁻⁹ standard cc/sec of helium maximum

Power Requirements

For all Mass Flow Meters (M180 Series): 15-24 VDC ±10%, 130 mA, regulated)

For Mass Flow Controllers (C180 Series):

C180M: 24 VDC ±10%, 700 mA regulated

C180H: 24 VDC ±10%, 1260 mA regulated

Ripple should not exceed 100 mV peak-to-peak

Control Range

2–100% of full scale flow; automatic shut-off at 1.9%.

Output Signals--Analog:

Linear 4–20 mA, 500 ohms maximum loop resistance plus one of the following (user selectable):

Linear 0–5 VDC, 1000 ohms minimum load resistance

Linear 0-10 VDC, 1000 ohms minimum load resistance

Linear 1-5 VDC, 1000 ohms minimum load resistance

Output Signals--Digital:

RS-232 (standard)

RS-485 or Remote Pilot module (optional)

Command Signal--Analog (choice of one):

Linear 4–20 mA

Linear 0–5 VDC

Linear 0-10 VDC

Linear 1-5 VDC

Command Signal--Digital:

RS-232 (standard)

RS-485 or Remote Pilot module (optional)

Physical Specifications:

Wetted Materials

316 stainless steel or equivalent, 410 stainless steel, Viton[®] “O”-rings and valve seat (standard). Other elastomers are available.

Optional Parts & Accessories:

The following optional accessories are available from your Authorized Sierra Instruments Representative or directly from Sierra Instruments. They are provided to improve your experience with the Smart-Trak Series 100 Mass Flow Meters and Controllers. Call or write for current pricing and availability.

Description	Order Code
Remote Pilot Module for Series 180	180-RDO
Power Supply with fly leads (bare wires), USA plug 100	T8F
Communication cable for WT option —6 foot	C6
Communication cable for WT option—20 foot	C20
Communication cable for WT option —33 foot	C33
Communication cable for WT option —Custom length (specify length in brackets)	C ()

Ordering Parts & Accessories:

Email Customer Service: service@sierrainstruments.com

FACTORY USA:

TOLL FREE: 800-866-0200
 PHONE: 831-373-0200
 FAX: 831-373-4402
 EMAIL: service@sierrainstruments.com

European Sales & Service Center:

PHONE: +31 72 5071400
 FAX: +31 72 5071401
 EMAIL: service@sierra-instruments.nl

Asia Sales & Service Center:

PHONE: + 8221 5879 8521
 FAX: +8621 5879 8586
 EMAIL: www.sierra-asia.com

Appendix C: Flow Chart for Remote Pilot Module User Interface

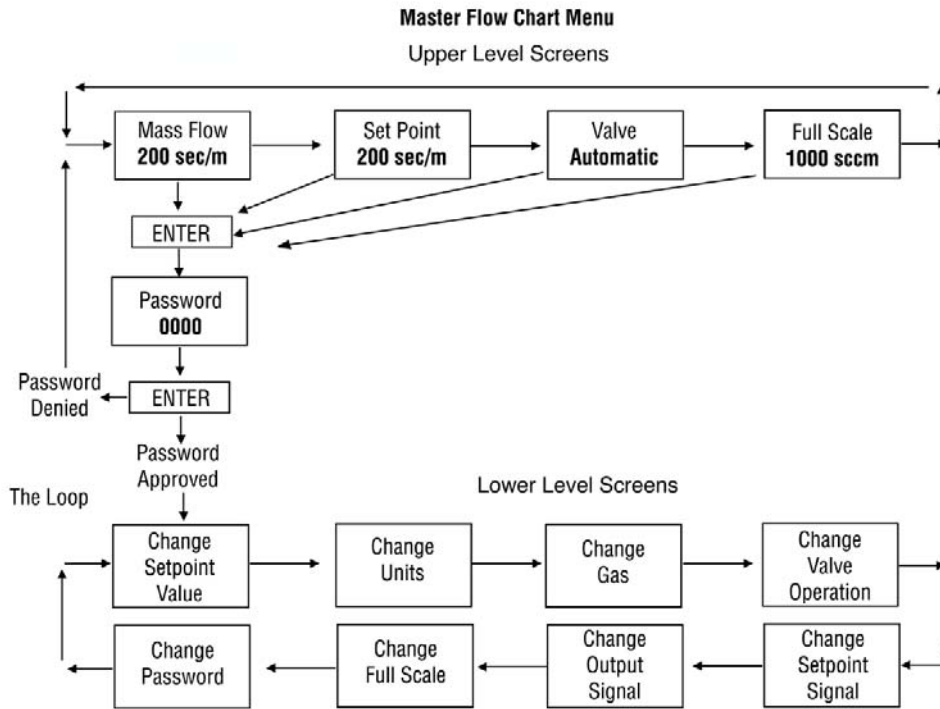

Note: If you press the escape key at any time, you will immediately return to the main Mass Flow screen in the Upper Level.

Appendix D: PIN Configuration and Wiring Diagram

Terminal Strip PCA Pin Configuration (inside the enclosure)

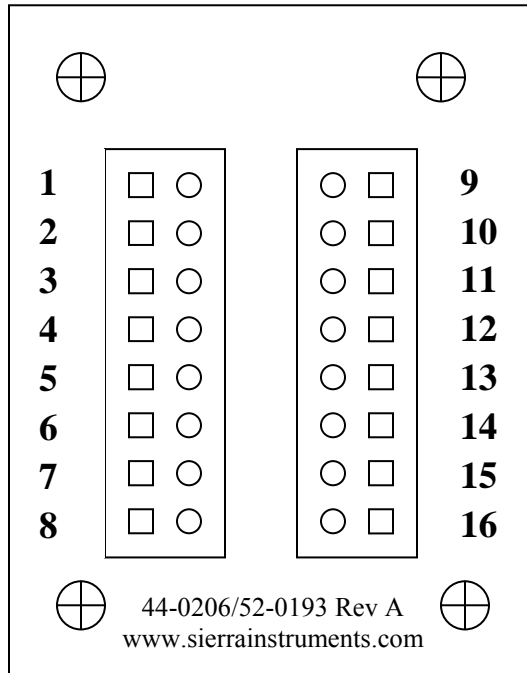

Wiring Functions, Location and Color Codes

#	Function	Wire Color with optional WT cable
1.	Analog Ground	Brown
2.	0-5 VDC Output (or 0-10, 1-5 VDC)	Red
3.	Analog Ground	Orange
4.	Valve Override (purge)	NOT CONNECTED
5.	Power Return (-)	Yellow
6.	Power Input (+)	Green
7.	RS-232 Transmit (out)	Purple
8.	Setpoint	Blue
9.	Not Used	NOT CONNECTED
10.	Analog Ground	Gray
11.	Reference Voltage (5 VDC External Setpoint & Valve Purge)	NOT CONNECTED
12.	Valve Override (close)	Black
13.	RS-232 Receive (in)	Pink
14.	4-20 mA Output	White
15.	Chassis (Earth) Ground	Tan (light Brown)
16.	Not Used	NOT CONNECTED



Note: Pins 1, 3, 5, and 10 are connected together inside the instrument. Sierra recommends individual wires.

Appendix E: Product Dimensions and Mounting

All dimensions are in inches with millimeters in (brackets).

M180M, M1 and C180M, M1 Front View



M180M, M1 and C180M, M1 Side View

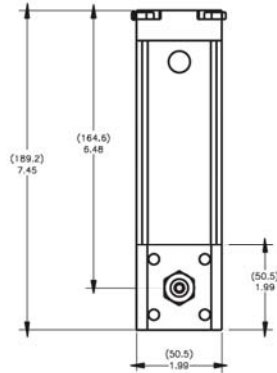

M180M, M1 and C180M, M1 Bottom View

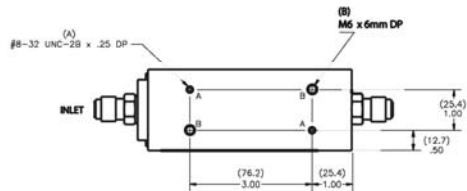

M180H, H1, H2 Front View

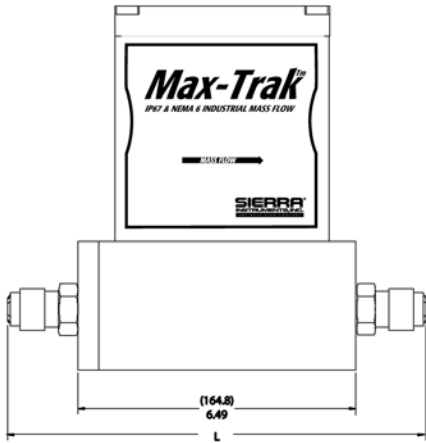

M180H, H1, H2 Side View

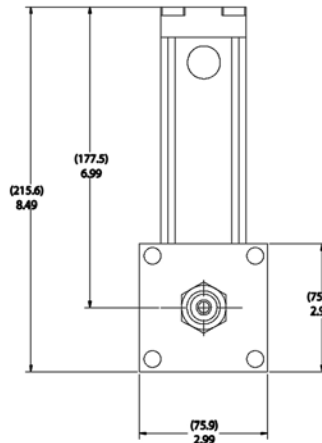

M180H, H1, H2 Bottom View

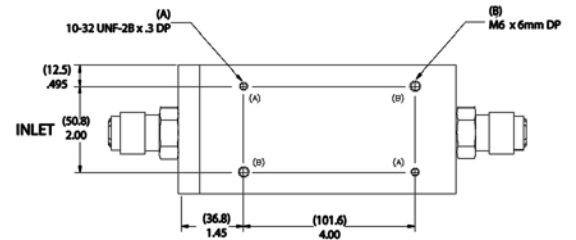

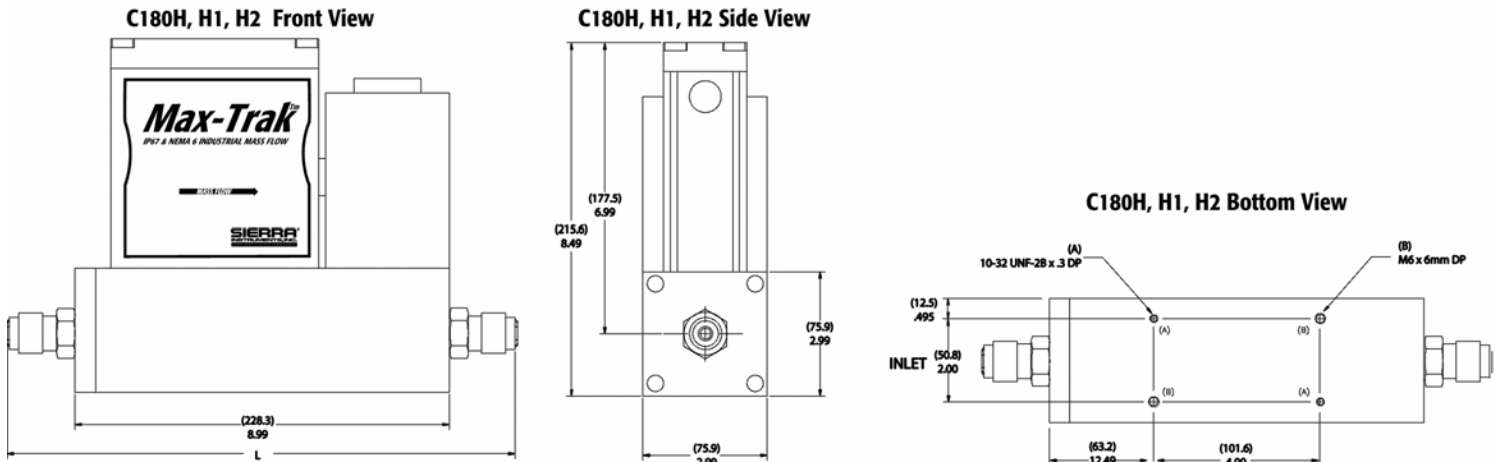

Dimension L

Fittings	Length with fittings in inches (mm)				
	C180M/M180M	M180H	M180H1, H2	C180H	C180H1, H2
1/8 compression	NA	NA	NA	NA	NA
1/4 compression	7.27 (186)	NA	NA	NA	NA
3/8 compression	7.39 (189)	NA	NA	NA	NA
1/2 compression	7.55 (194)	8.92 (229)	NA	10.37 (266)	NA
1/4 VCO	6.81 (175)	NA	NA	NA	NA
1/2 VCO	7.25 (186)	8.56 (220)	NA	10.01 (267)	NA
3/4 VCO	NA	NA	8.78 (225)	NA	11.28 (289)
1/4 VCR	7.13 (183)	NA	NA	NA	NA
1/2 VCR	7.43 (191)	9.00 (231)	NA	10.45 (268)	NA
6 mm compression	7.29 (187)	NA	NA	NA	NA
10 mm compression	7.45 (191)	NA	NA	NA	NA
12 mm compression	7.63 (196)	8.90 (228)	NA	10.35 (265)	NA
1/4 FNPT	7.10 (182)	NA	NA	NA	NA
3/8 FNPT	7.25 (186)	NA	NA	NA	NA
1/2 FNPT	NA	9.14 (234)	NA	10.59 (272)	NA
3/4 FNPT	NA	NA	9.30 (238)	NA	11.30 (290)
3/4 compression	NA	9.24 (237)	9.18 (235)	10.69 (274)	11.68 (300)
1 inch compression	NA	NA	9.52 (244)	NA	12.02 (308)