

High Performance Digital Gas Mass Flow Meters & Controllers

FEATURES

- Measure and control gas mass flow rates up to 1000 slpm
- Pressure up to 1500 psig (100 barg)
- Ideal for OEM, industry or research applications
- True linear performance provides high accuracy and great flexibility in multiple gases
- With Dial-A-Gas® Technology, you select from up to ten pre-programmed gases or substitute your own
- Unique Pilot Module (mounted or hand-held) lets you view and change critical control functions including:
 - Gas type
 - Setpoint value
 - Zero value
 - Span value
 - Engineering units
 - Output signals
 - Full scale adjust
- All control functions are also available from your PC or workstation via supplied SmartTrak 100 software
- 316 stainless steel construction
- Choose from multiple analog or digital signals including: RS-232, RS-485, 4-20 mA, 0-5, 1-5, 0-10 VDC
- Small footprint and great flexibility facilitates replacement of older MFM or MFC
- Factory calibration done with primary standards directly traceable to NIST
- Proprietary frictionless-hovering direct-acting control valve technology
- Add Compod™ for MODBUS RTU networking capability
- Single-sided 24 VDC input power reduces installation cost and complexity
- CE approved

SmartTrak 100



DESCRIPTIONS

SmartTrak® 100 Series features unprecedented performance, user-friendly features, and flexibility. The 100 Series gives users the world's most linear sensor, smoother valve performance, more robust electronics and even more control over a wide range of functions. The result is a series of mass flow meters and controllers that demonstrates premium flow instrumentation which is easy to use.

The 100 Series is designed so that the physics are correct. Excellent performance results from a patented, inherently linear Laminar Flow Element (LFE) design, advanced platinum sensor technology, and Sierra's proprietary frictionless-hovering control valve.

The 100 Series is available with an innovative and user-friendly Pilot Module, a front-mounted or hand-held control device that allows users to Dial-A-Gas®, change flow rate, modify engineering units or re-configure the instrument. With the Pilot Module, the user can set zero, span, and full scale for each of the 10 different gases independently to accommodate unexpected application or system design changes.

With the addition of Sierra's Compod™, the 100 Series transforms into a fully network-enabled MODBUS RTU device.

For the ultimate in performance, flexibility and value, SmartTrak is the smart choice.



SIERRA
EXPERIENCE OUR PASSION FOR FLOW!



www.sierrainstruments.com

PERFORMANCE SPECIFICATIONS

Accuracy

Standard: $\pm 1.0\%$ of full scale including linearity at operating conditions
 $(\pm 2.0$ of full scale for 100M from 201-300 slpm)

Dial-A-Gas

$\pm 1.0\%$ of full scale in all 10 standard gases (see chart below)

Repeatability

$\pm 0.2\%$ of full scale

Temperature Coefficient

$\pm 0.025\%$ of full scale per $^{\circ}\text{F}$ ($\pm 0.05\%$ of full scale per $^{\circ}\text{C}$), or better

Pressure Coefficient

$\pm 0.01\%$ of full scale per psi ($\pm 0.15\%$ of full scale per bar), or better

Response Time

300 millisecond time constant; 2 seconds (typical) to within $\pm 2\%$ of final value (includes settling time), faster or slower available upon request.

OPERATING SPECIFICATIONS

Mass Flow Rates

100L Low Flow: 0 -10 sccm to 0 -50 slpm
 C100L High Pressure: 100 sccm to 20 slpm
 100M Medium Flow: 0-20 to 0-300 slpm (up to 400 slpm available)
 100H High Flow: 0-100 to 0-1000 slpm (higher flows available)
 Flow ranges specified are for an equivalent flow of nitrogen at 760 mm Hg and 21°C (70°F); other ranges in other units are available (e.g., nlpm, scfh, nm^3/h , kg/h)

For measuring or controlling flows below 5 sccm, please consider Sierra's Model 101 Micro-Trak™. For measuring or controlling flows above 1000 slpm, please consider Sierra's Model 180 MaxTrak High pressure unit should be used for pressures from 500 to 1500 psig (33.3 to 100 barg).

Gases

Measures and controls all clean gases including corrosives and toxics; specify when ordering.

The following ten gases make up the Dial-A-Gas® feature of every SmartTrak instrument; up to nine alternate gases may be substituted.

Dial-A-Gas Flow Rates				
Gas	Max Flow Rate (slpm)	Max Flow Rate (slpm)	Max Flow Rate (slpm)	Max Flow Rate (slpm)
	Low Flow Size	High Pressure	Medium Flow Size	High Flow Size
Air	50	20	300	1000
Argon (Ar)	69.9	29	419.4	1398
Carbon Dioxide (CO ₂)	36.8	15	221.1	737
Carbon Monoxide (CO)	50.1	20	300.6	1002
Methane (CH ₄)	37.7	15	226.2	754
Helium (He)	69.9	29	419.7	1399
Hydrogen (H ₂)	50	20	300.3	1001
Oxygen (O ₂)	49.9	20	299.4	998
Nitrogen (N ₂)	50.1	20	300.6	1002
Nitrous Oxide (N ₂ O)	35.8	15	214.8	716

® Smart-Trak & Dial-A Gas are registered trademarks of Sierra Instruments, ® Nylon, Viton, Neoprene, Kalrez are registered trademarks of DuPont, ®Windows is a registered trademark of Microsoft

OPERATING SPECIFICATIONS (continued)

Gas and Ambient Temperature

32 to 122°F (0 to 50°C)

Standard Gas Pressure

500 psig (33.3 barg) maximum, burst tested to 750 psig (52 barg)

High Pressure

1500 psig (100 barg) maximum, burst tested to 2250 psig (150 barg)

Leak Integrity

5 X 10⁻⁹ atm cc/sec of helium or better

Power Requirements (ripple should not exceed 100 mV peak-to-peak)

For Mass Flow Meters:
 15-24 VDC $\pm 10\%$, (230 mA, regulated)
 For Mass Flow Controllers:
 C100L: 24 VDC $\pm 10\%$ (500 mA, regulated)
 C100L High Pressure: 24 VDC $\pm 10\%$ (800 mA, regulated)
 C100M: 24 VDC $\pm 10\%$, (800 mA, regulated)
 C100H: 24 VDC $\pm 10\%$, (1260 mA, regulated)

Control Range For Controllers

2–100% of full scale flow; automatic shut-off at 1.9%.

Output Signal

Analog:
 Linear 4–20 mA, 500 ohms maximum loop resistance and one of the following (user selectable):
 Linear 0–5 VDC, 1000 ohms minimum load resistance
 Linear 0-10 VDC, 1000 ohms minimum load resistance
 Linear 1-5 VDC, 1000 ohms minimum load resistance

Digital:

RS-232 standard, RS-485 optional
 Pilot Module Display optional

Command Signal

Analog (choice of one):
 Linear 4–20 mA, 0–5 VDC, 0-10 VDC, 1-5 VDC

Digital:

RS-232 standard, RS-485 optional
 Pilot Module Display optional

Wetted Material

316 stainless steel or equivalent; 416 stainless steel;
 Viton "O"-rings and valve seat standard;
 other elastomers are available (consult factory)

High Pressure Version: Viton "O"-rings and polyamide valve seat

OPTIONAL COMPOD

RS-485 communication with MODBUS RTU protocol allows digital multi-drop networks

Available with optional LCD display

Internal gas flow totalizer with adjustable pulse output

Two digital outputs and one analog input can be configured by user with MODBUS or included software for a wide variety of process controls



Pressure Drop Across a Meter

Pressure must be above the values in the table below. Note that pressure increases with flow rate.

Minimum Pressure Drop for Air, Mass Flow Meters					
Flow Rate (slpm)	Pressure Drop in PSI (mbar)				
	Low Flow ¼ inch fittings (Standard)	Low Flow 3/8 inch fittings (Optional)	Medium Flow 3/8 or ½ inch fittings	High Flow Small Bore (100H) (std up to 500 slpm) ½ comp fittings	High Flow Large Bore (H1, H2) (std 501-1000 slpm) ¾ comp fittings
0.1	0.36 (24.5)	N/A	N/A	N/A	N/A
0.5	0.36 (24.5)	N/A	N/A	N/A	N/A
1	0.37 (25.4)	N/A	N/A	N/A	N/A
10	0.46 (31.7)	0.41 (28.6)	N/A	N/A	N/A
20	0.66 (45.7)	0.47 (32.7)	0.5 (34)	N/A	N/A
30	N/A	0.59 (40.9)	0.5 (34)	N/A	N/A
40	N/A	0.77 (53.3)	0.5 (34)	N/A	N/A
50	N/A	1.00 (68)	0.5 (34)	N/A	N/A
100	N/A	N/A	1.0 (68)	1.0 (68)	0.5 (34)
150	N/A	N/A	2.0 (136)	1.2 (81.6)	0.5 (34)
200	N/A	N/A	3.0 (204)	1.5 (102)	0.5 (34)
250	N/A	N/A	4.0 (272)	1.8 (122.4)	0.5 (34)
300	N/A	N/A	5.5 (374)	2 (136)	0.6 (40.8)
350	N/A	N/A	N/A	2.5 (170)	0.7 (47.6)
400	N/A	N/A	N/A	3 (204)	0.9 (61.2)
450	N/A	N/A	N/A	3.5 (238)	1.1 (74.8)
500	N/A	N/A	N/A	4 (272)	1.3 (88.4)
750	N/A	N/A	N/A	6 (408)*	3.0 (204)
1000	N/A	N/A	N/A	10 (680)*	5.0 (340)

Note: Tested at 21°C, outlet at ambient pressure

*Larger fittings recommended for these flow rates, as small fittings reduce overall performance

Differential Pressure Requirement for Controllers

Minimum Differential Pressure Requirement for Air, Mass Flow Controllers					
Flow Rate (slpm)	Pressure Drop in PSI (mbar)				
	Low Flow High Pressure Version ¼ inch fittings (Standard)	Low Flow 3/8 inch fittings (Optional)	Medium Flow 3/8 or ½ inch fittings	High Flow Small Bore (100H) (std up to 500 slpm) ½ comp fittings	High Flow Large Bore (H1, H2) (std 501-1000 slpm) ¾ comp fittings
0.1	1 (68)	1 (68)	N/A	N/A	N/A
1	1.5 (102)	1.28 (87)	N/A	N/A	N/A
10	6 (408)	3.8 (258)	N/A	N/A	N/A
20	12 (816)	6.6 (449)	1 (68)	N/A	N/A
30	15 (1020) *	9.4 (639)	1.2 (82)	N/A	N/A
40	30 (2040) *	12.2 (830)	1.6 (110)	N/A	N/A
50	40 (2720) *	15 (1020)	2 (136)	N/A	N/A
100	N/A	N/A	5 (340)	1.5 (102)	1.0 (68)
150	N/A	N/A	10 (680)	2 (136)	1.0 (68)
200	N/A	N/A	15 (1020)	4.5 (306)	1.0 (68)
250	N/A	N/A	20 (1360)	5.5 (374)	1.5 (102)
300	N/A	N/A	25 (1700)	6.5 (442)	2.0 (136)
350	N/A	N/A	N/A	8.5 (578)	3.0 (204)
400	N/A	N/A	N/A	10.5 (714)	4.0 (272)
450	N/A	N/A	N/A	13 (884)	5.0 (340)
500	N/A	N/A	N/A	15 (1020)	6.0 (408)
750	N/A	N/A	N/A	N/A	15 (1020)
1000	N/A	N/A	N/A	N/A	20 (1360)

Note: Tested at 21°C, outlet at ambient pressure

*Larger fittings recommended for these flow rates as ¼ inch fittings reduce overall performance;

N/A for high pressure version (flow is limited to 20 slpm)



SmartTrak 100

SmartTrak 100 with Compod

SmartTrak 100 High Pressure

Hand-Held Pilot Module

PHYSICAL DIMENSIONS

All dimensions are in inches with (mm) in brackets. Certified drawings are available on request.

Fittings	Dimension L						
	Length with Fittings in Inches (mm)						
	C100L, M100L	C100M	M100M 100 High Pressure	M100H	M100H1, H2	C100H	C100H, H2
1/8 compression	4.84 (124)	NA	NA	NA	NA	NA	NA
1/4 compression	5.02 (129)	6.52 (167)	6.02 (154)	NA	NA	NA	NA
3/8 compression	5.14 (132)	6.64 (170)	6.14 (157)	NA	NA	NA	NA
1/2 compression	5.3 (135)	6.80 (174)	6.30 (162)	8.29 (229)	NA	10.37 (266)	NA
1/4 VCO	4.56 (117)	6.06 (155)	5.56 (143)	NA	NA	NA	NA
1/2 VCO	5.00 (128)	6.50 (167)	6.00 (154)	8.56 (220)	NA	10.01 (257)	NA
3/4 VCO	NA	NA	NA	NA	8.78 (225)	NA	11.28
1/4 VCR	4.88 (125)	6.38 (164)	5.88 (151)	NA	NA	NA	NA
1/2 VCR	5.18 (133)	6.68 (171)	6.18 (158)	8.98 (230)	NA	10.43 (267)	NA
6 mm compression	5.04 (129)	6.54 (168)	6.04 (155)	NA	NA	NA	NA
10 mm compression	5.20 (133)	6.70 (172)	6.20 (159)	NA	NA	NA	NA
12 mm compression	5.38 (138)	6.88 (176)	6.38 (164)	8.90 (228)	NA	10.35 (265)	NA
1/4 FNPT	4.85 (124)	6.35 (163)	5.85 (150)	NA	NA	NA	NA
3/8 FNPT	NA	6.50 (167)	6.00 (154)	NA	NA	NA	NA
1/2 FNPT	NA	NA	NA	9.14 (234)	NA	10.59 (272)	NA
3/4 FNPT	NA	NA	NA	NA	9.30 (238)	NA	11.80
3/4 compression	NA	NA	NA	9.24 (237)	9.18 (235)	10.69 (274)	11.68
1 inch compression	NA	NA	NA	NA	9.52 (244)	NA	12.02

All dimensions are in inches with [mm] in brackets. Certified drawings are available on request.

M100L & C100L Front View

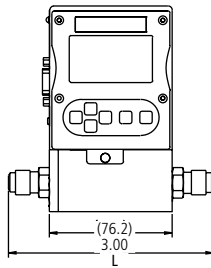

M100L & C100L Inlet View

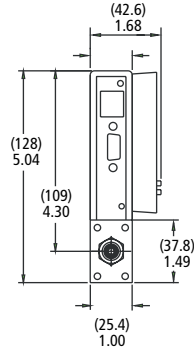

M100L & C100L Bottom View

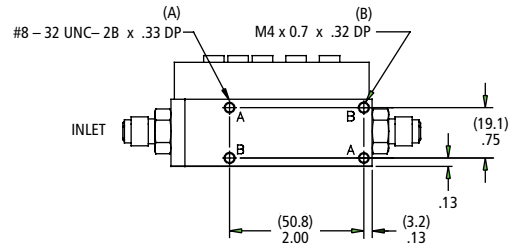

C100 High Pressure Front View

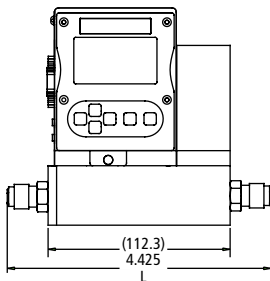

C100 High Pressure Inlet View

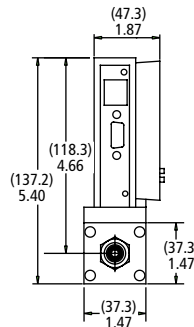

C100 High Pressure Bottom View

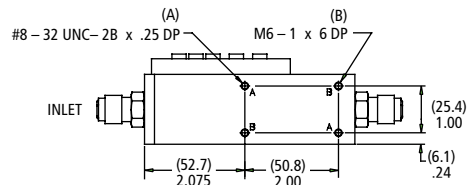

M100M Front View

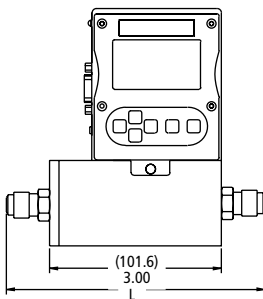

M100M Inlet View

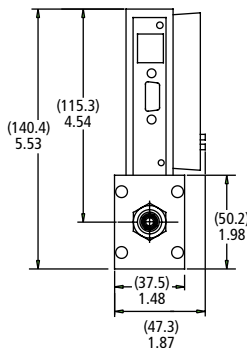

M100M Bottom View

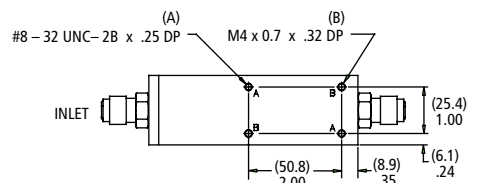

C100M Front View

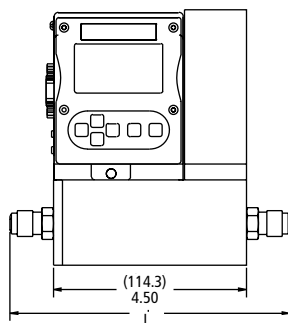

C100M Inlet View

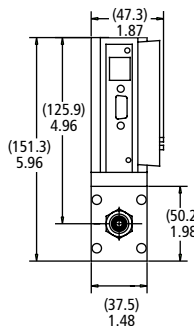

C100M Bottom View

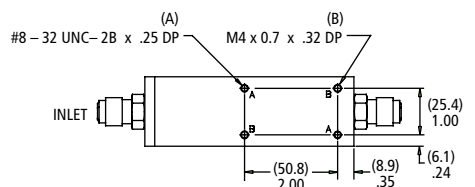

PHYSICAL DIMENSIONS

All dimensions are in inches with [mm] in brackets. Certified drawings are available on request.

M100H Front View

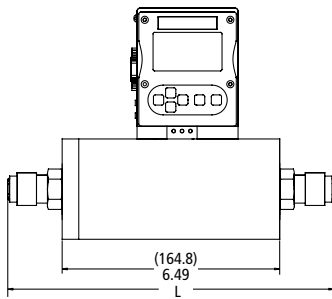

M100H Side View

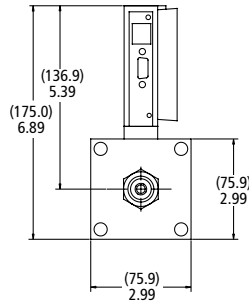

M100H Bottom View

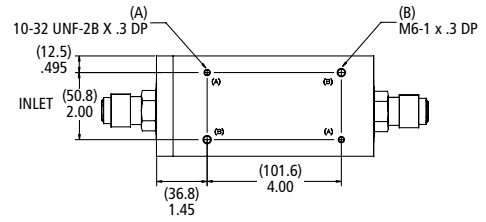

C100H Front View

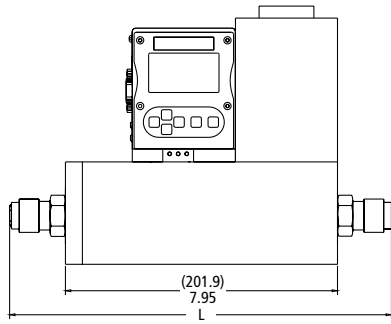

C100H Side View

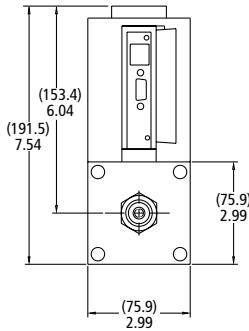

C100H Bottom View

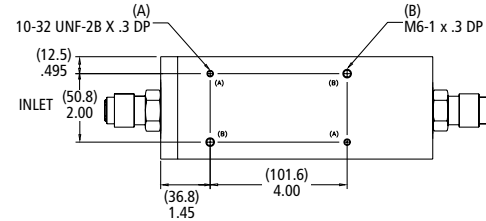

M100H1, H2 Front View

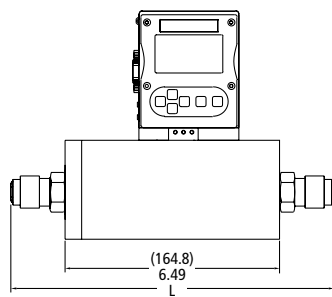

M100H1, H2 Side View

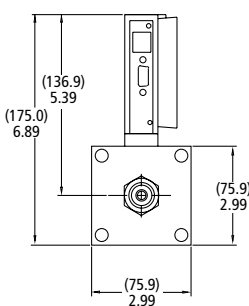

C100H1, H2 Bottom View

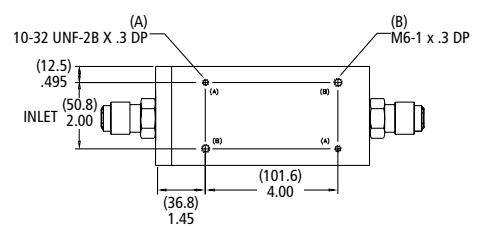

C100H1, H2 Front View

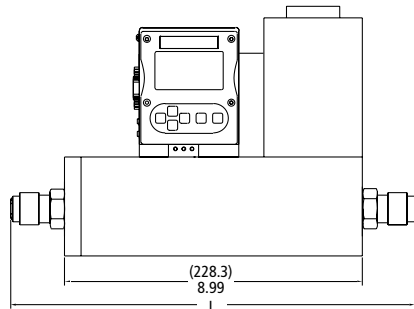

C100H1, H2 Side View

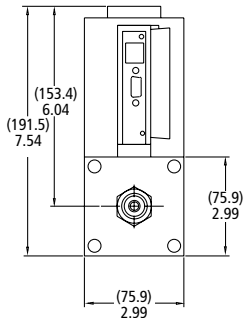

C100H1, H2 Bottom View

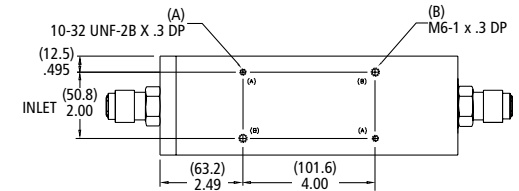

ORDERING INFORMATION

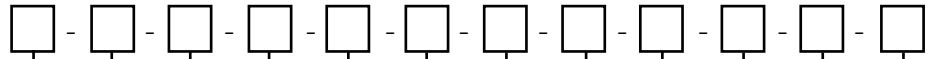

PARENT NUMBER
M100 SmartTrak Mass Flow Meter (500 psig, 33.3 barg)
C100 SmartTrak Mass Flow Controller (500 psig, 33.3 barg)
C100 SmartTrak High Pressure Mass Flow Controller (1500 psig, 100 barg)

FLOW RANGE
L Flows from 0-10 sccm to 0-50 slpm
L-HP Flows from 100 sccm to 0-20 slpm
M Flows from 0-20 slpm to 0-200 slpm
M1 Flows from 0-201 slpm to 0-300 slpm
H Flows from 0-100 slpm to 0-500 slpm
H1 Flows from 0-501 slpm to 0-800 slpm
H2 Flows from 0-801 slpm to 0-1000 slpm

PILOT MODULE DISPLAY/INTERFACE
NR No display/interface
DD Pilot module display/interface
RD Remote pilot module display/interface

INLET/OUTLET FITTINGS

1 1/8 compression (max 5 slpm)	10 6mm compression (max 30 slpm)
2 1/4 compression (Std to 30 slpm)	11 10mm compression (max 300 slpm)
3 3/8 compression (Std 30 to 300 slpm)	12 12 mm compression (max 500 slpm)
4 1/2 compression (max 500 slpm)	13 1/4 FNPT (max 300 slpm)
5 1/4 VCO (max 50 slpm)	14 3/8 FNPT (max 300 slpm)
6 1/2 VCO (max 500 slpm)	15 1/2 FNPT (max 500 slpm)
7 3/4 VCO (max 1000 slpm)	16 3/4 FNPT (max 1000 slpm)
8 1/4 VCR (max 50 slpm)	17 3/4 compression (max 1000 slpm)
9 1/2 VCR (max 500 slpm)	18 1 inch compression

FLOW BODY ELASTOMERS
OV1 Viton or equivalent (standard)
ON1 Neoprene or equivalent (not available for high pressure version)

VALVE SEAT (C100 flow controllers only, high pressure must use PA1)
SV1 Viton or equivalent **SK2** Kalrez or equivalent (100M)
SN1 Neoprene or equivalent **SK3** Kalrez or equivalent (100H)
SK1 Kalrez or equivalent (100L) **PA1** Polyamide (high pressure version only)

INPUT POWER
PV1M 15-22 VDC, linear (flow meters only)
PV1C 15-22 VDC, linear (C100L only)
PV2 24 VDC, linear (standard)

OUTPUT SIGNAL
V1 4-20 mA and 0-5 VDC, linear
V2 4-20 mA and 1-5 VDC, linear
V3 4-20 mA and 0-10 VDC, linear

EXTERNAL SETPOINT SIGNAL (flow controllers only)
S0 Pilot Module/RS-232 (standard for DD, RD) **S3** 0-10 VDC
S1 0-5 VDC (standard for NR) **S4** 4-20 mA
S2 1-5 VDC

ELECTRICAL CONNECTION
C0 15 PIN mating connector with no cable **C6** 6 foot (1.83m) cable
C1 6 inch (150mm) cable **C ()** Custom length cable
C3 3 foot (1m) cable

OPTIONS
GS Gas substitution (replace up to 9 Dial-A-Gas gases)
LF Low flow calibration (required for 0-20 sccm and below)

GAS FLOW RATE

FOR ACCESSORIES AND ADDITIONAL CABLES PLEASE CONTACT YOUR LOCAL SIERRA DISTRIBUTOR



100 Series Family

PURCHASE ONLINE

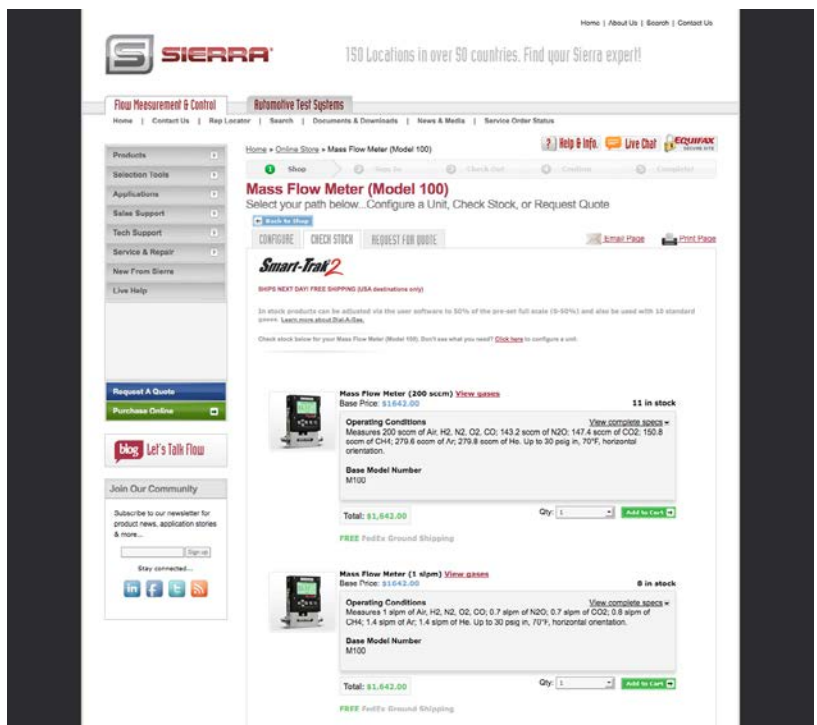

In Stock Products. Ship Next Day.
www.sierrainstruments.com/shop