

Accurate & Consistent Gas Mixing

Why Mass Flow Control Provides Pure, Repeatable Results

APPLICATION CHALLENGES

For many experiments it's critical to achieve precision control in **gas mixing and blending applications**. In fact, the quality of research and results depends on trusting all the variables in an experiment, including controlling your exact mix or blend of gases.

Gas mixing applications involve the creation of artificial atmospheres or other gas mixtures. In practice, two or more gases are mixed (blended) in a chamber until the specified concentrations (or partial pressures) of each gas are achieved. **Flow controllers** are commonly used to create these gas mixtures.

With traditional mass flow controllers, gas mixtures are notorious for inaccuracy. During calibration, most instruments are "curve-fit" to the application because they are not linear. They are calibrated with a primary gas, but a gas mixture has different properties than the primary gas, so the original curve is not correct for the mixture. Due to this, in most gas mixing applications scientists need to use multiple mass flow controllers, each one calibrated for one of the component gases.

PRECISION FLOW CONTROL AT LOW FLOW RATES

Another challenge is precision control at low flows. Since the chamber is filled with the component gases, the pressure will increase, which will result in backpressure at the measuring instrument. Some flow controllers, especially those based on differential pressure (ΔP), will lose accuracy as backpressure changes. Differential pressure devices also perform poorly with low flows because they require a pressure drop to operate. At low flows, of course, a low pressure drop occurs, so the sensitivity of the meter may not be sufficient.

WHY MASS FLOW CONTROL IMPROVES QUALITY OF RESEARCH DATA

The two common methods for measuring and controlling flow rates are mass flow and **volumetric flow**. In most research, especially those involving biological or chemical reactions, mass is the quantity of interest. Mass flow depends on the number of molecules in the flow, not the volume occupied by these molecules. This volume will change with temperature or pressure. Higher pressure means the same number of molecules must occupy a smaller volume (assuming the temperature stays constant). In contrast, when temperatures are higher, the volume occupied by these molecules expands (assuming the pressure stays constant).

These two facts are based on the Ideal Gas Law (See Figure 1).

Mass flow controllers that use thermal mass flow technology are ideal for research because they provide scientists with direct mass flow control, which is unaffected by temperature and pressure fluctuations.

— LEARN MORE —

sierrainstruments.com/library/infographics/thermal-mass-flow-advantage

— WATCH VIDEO —

sierrainstruments.com/library/videos/massflow-versus-volumetric



SmartTrak® 100 Digital Mass Flow Controllers for Gas Mixing & Blending

Benefits of Capillary Thermal Mass Flow Controllers

- Direct mass flow with +/- 0.5 percent full-scale accuracy
- Patented, inherently linear laminar flow element design
- Mass flow rates up to 1,000 slpm and down to 0 to 0.1 sccm
- Pressure to 5,000 psig (345 barg) with low pressure drop of 4.5 psid (310 mBard)
- Provides smooth and flexible valve performance, even at low flows
- True multigas digital mass flow controller—up to 10 pre-programmed gases
- 10-point NIST calibration on primary standard

— LEARN MORE —

sierrainstruments.com/scientific-lab

THE IDEAL GAS LAW

$$PV = nRT$$

WHERE:

P is the pressure of the gas

V is the volume of the gas

n is the amount of substance of gas (in moles)

R is the ideal gas constant

T is the absolute temperature of the gas

Figure 1: Ideal Gas Law

CASE STUDY: CREATING ARTIFICIAL ATMOSPHERES AT MONTEREY BAY AQUARIUM RESEARCH INSTITUTE (MBARI)

Dr. James Barry, a scientist from the prestigious Monterey Bay Aquarium Research Institute (MBARI), had a typical gas mixing application in which he had to control the composition of three different gases. To simulate past, present, and future ocean conditions he needed to vary the O₂ levels from 1% to 20%, N₂ from 80% to 99% and CO₂ levels from 180 to 1500 ppm, depending on the desired atmosphere or ocean condition.

To solve this challenge, Dr. Barry used Sierra's SmartTrak 100 mass flow controllers with its Pilot Module and Dial-A-Gas® capabilities to control and stabilize the amounts of gases that were flowing into their aquariums. For this set up, a miniature Human Machine Interface (HMI) monitors and controls the system automatically by communicating with three SmartTrak 100 Mass Flow Controllers. Each MFC regulates the flow of one gas into the tank while the HMI maintains the exact portion of gas ratio defined by comparing MFC data with the gas mix equations to make sure the gas mixture is accurate and consistent (See Figure 2).

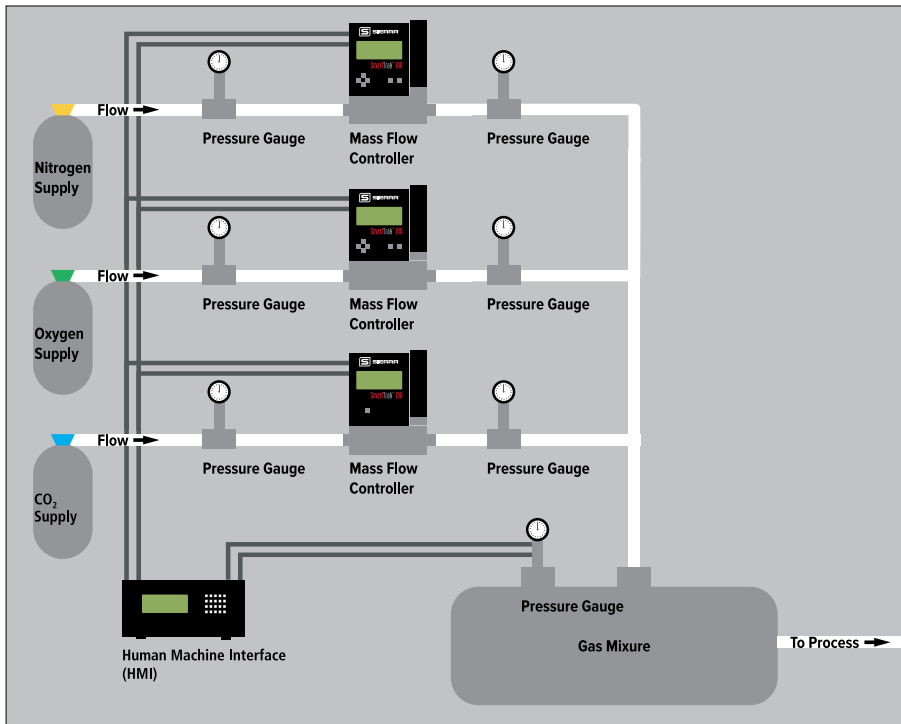

Figure 2: Typical Gas Mixing and Blending Application

SmartTrak 100 Advantage

With the remote Pilot Module, Dr. Barry was able to change his CO₂, N₂ and O₂ flow rates instantly and remotely, creating many varieties of oceanic atmospheres in his tanks with the same set of conditions—same water, temperature, and animals.

The SmartTrak 100 MFC delivers smooth, stable, accurate, and repeatable gas mass flow control you can rely on, every time. In addition, the powerful solenoid valve of the mass flow controller provides precision control and accuracy even at the very low flow range of 1 to 10 sccm, unaffected by upstream gas temperature and pressure fluctuations.

The SmartTrak is CE approved, available in any flow range you specify from low flows (0 to 0.1 sccm) to high flows (to 1000 slpm) including a small footprint at 50 slpm (ideal for OEMs) and full suite of digital communication for easy process integration. SmartTrak also offers a wide operating range for temperature and pressure with high- pressure options (up to 5000 psig) and low-pressure drop (4.5 psid).

— LEARN MORE — sierrainstruments.com/scientific-lab



SmartTrak® 100 with Compad™ & Pilot Module

- Pilot Module with Dial-A-Gas® gives you the ability to remotely control and stabilize gases
- View and change every aspect of the instrument with push button display or remote Pilot Module
- Plug-in compod to make MFC a mini PLC with Modbus
- Small footprint is perfect for OEMs
- Customized engineering and lifetime support
- Profibus & Foundation Fieldbus digital communications
- Need fast shipping? Buy online sierrainstruments.com/shop