



Introducing a New Paradigm for Thermal Dispersion Mass Flow

By John G. Olin, Ph.D., Sierra Instruments, Inc.

A S I E R R A W H I T E P A P E R

www.sierrainstruments.com

NORTH AMERICA

5 Harris Court, Building L / Monterey, CA 93940 / USA
800.866.0200 / 831.373.0200 / fx 831.373.4402

EUROPE

Bijlmansweid2 / 1934RE Egmond aan den Hoef
The Netherlands
+31 72 5071400 / fx +31 72 5071401

ASIA - PACIFIC

Second Floor Building 5 / Senpu Industrial Park
25 Hangdu Road Hangtuo Town / Pu Dong New District
Shanghai, P.R. China Post Code 201316
+8621 5879 8521/22 / fx +8621 5879 8586



INTRODUCTION

Since the publication of the American Society of Mechanical Engineers (ASME) standard on thermal dispersion mass flowmeters in 2011, there have been major advancements in the technology. A review of that standard and a discussion of technology advancements provide the background to understanding groundbreaking innovations in sensor design. That, along with a comprehensive algorithm facilitated by current hyper-fast microprocessors, has created a new paradigm for the measurement of the mass flow rate of gases by means of thermal dispersion technology.

The ASME Standard

In recognition of the widespread use of thermal dispersion mass flowmeters all over the world, the ASME published, in 2011, ASME MFC-21.2-2010, *Measurement of Fluid Flow by Means of Thermal Dispersion Mass Flowmeters*¹. This ASME standard establishes a common terminology and gives guidelines for the description, principle of operation, selection, installation, and flow calibration of thermal dispersion flowmeters for the measurement of the mass flow rate of a fluid in a closed conduit.

History and Description

Thermal dispersion mass flowmeters measure the mass flow rate of fluids, typically gases, flowing through a pipe or duct. Their first general description is attributed to L. V. King who, in 1914, published his famous King's Law² revealing how a heated wire immersed in a fluid flow measures the mass velocity at a point in the flow. He called his instrument a "hot-wire anemometer," and these instruments have been used in fluid mechanics research and as light-duty mass flowmeters and point-velocity instruments. It was not until the 1960s and 1970s that industrial-grade, metal-clad thermal dispersion mass flowmeters that could solve industry's more rugged needs became commercially available.

Thermal dispersion mass flowmeters measure the heat convected into the boundary layer of the gas flowing over the surface of a heated velocity sensor immersed in the flow. Since it is the molecules of the gas that bear its mass and carry away the heat, thermal dispersion mass flowmeters directly measure mass flow rate.



Typical gases monitored include air, methane, natural gas, carbon dioxide, nitrogen, oxygen, argon, helium, hydrogen, propane, and stack gases. Mixtures of these gases and mixtures of hydrocarbon gases are also included. Common applications are: combustion air; preheated air; compressed air; fluid power; boilers; electric power plants; cooling, heating, and mixing; drying of materials; food and beverage industries; natural gas distribution; aeration and digester gas monitoring in wastewater treatment plants; cogeneration with biogas; fuel gas; flare gas; semiconductor manufacturing; heating, ventilation, and air conditioning; single and multipoint stack gas monitoring; and chemical reactors.

Thermal dispersion mass flowmeters have two primary configurations: in-line and insertion.

- In-line flowmeters are applied to pipes and ducts with diameters typically ranging from about 10 to 100 mm (0.25 to 4.0 inch pipe sizes). Process connections include flanges, pipe threads, and compression fittings. Some manufacturers offer a built-in flow conditioner that reduces the length of upstream straight pipe required to achieve independence of upstream flow disturbances.
- Insertion flowmeters usually are applied to larger pipes, ducts, and other flow conduits having equivalent diameters typically ranging from approximately 75mm to 5m (3.0 inches to 200 inches). Compression fittings and flanges are commonly used process connections.

Principle of Operation

Figure 1 shows the flow sensor of a typical traditional thermal dispersion mass flowmeter currently in use. Because it has a total of two temperature sensing elements, the flow sensor in Figure 1 is called a “two-sensor” thermal dispersion flow sensor. It has a velocity sensor (mass flow sensor) and a separate gas temperature sensor immersed in the flow stream, each enclosed in a tubular metal sheath. The velocity sensor has a single electrically self-heated temperature sensor element located in its tip that both heats the velocity sensor and measures its average temperature T_v . The gas temperature sensor has a single non-self-heated temperature sensor element located in its tip that measures the gas temperature T_g . Both temperature sensor elements are resistance temperature sensors (RTDs).

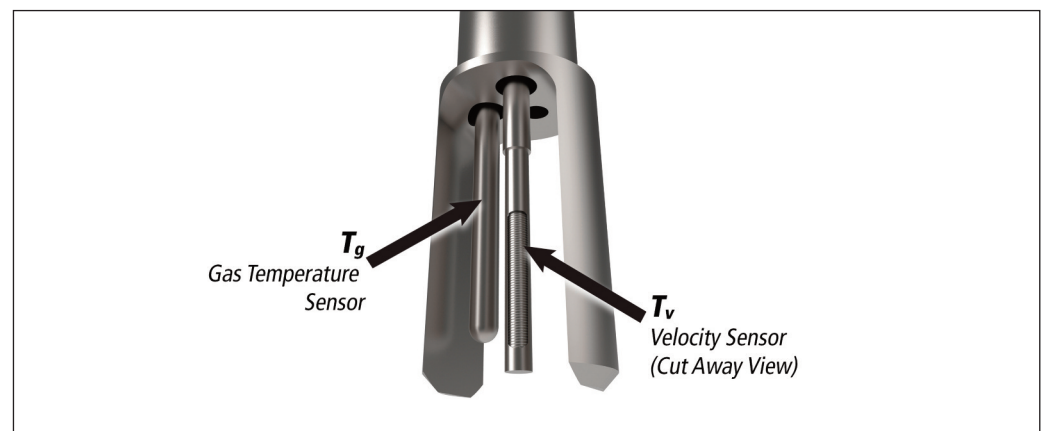

Figure 1. Traditional “Two-Sensor” Thermal Dispersion Flow Sensor



The meter's electronics, operating in the preferred constant-differential temperature mode, maintains at a constant value the difference $\Delta T = T_v - T_g$ between the temperature of the heated velocity sensor T_v and the gas temperature T_g . The output signal is the electrical power W supplied to the heated velocity sensor that is required to keep ΔT at its constant set-point value (usually 50 degrees C). In operation, once flow begins, the flowing gas molecules convect heat away from the velocity sensor, tending to lower ΔT . The electronics respond by delivering just enough electrical power W to the velocity sensor to bring ΔT back to its constant set-point value. The power W is the raw output of the meter and is directly proportional to mass flow rate.

In steady state, the first law of thermodynamics states that the energy (or power W) flowing into a defined control volume equals the energy flowing out of the control volume. In a thermal dispersion mass flowmeter, the control volume is the heated section of the velocity sensor. The first law for this control volume is

$$W = Q_1 + Q_{\text{tip}} + Q_{\text{stem}}$$

(Equation 1)

In Equation (1), Q_1 is the heat rate (watts) transferred from the heated control volume to the flowing gas by forced convection. This is the quantity of interest. Q_{tip} and Q_{stem} are the heat rates (watts) conducted from the heated control volume to the tip and stem of the velocity sensor, respectively. Collectively, they constitute the heat rate lost via "stem conduction" and are an unwanted by-product of traditional flowmeters. The referenced ASME standard¹ describes the principle of operation and the first law of thermodynamics in much more detail and is generally applicable to both the traditional technology and the advanced technology discussed in the following.

New Innovation Drives Much Higher Performance

While the traditional thermal dispersion mass flowmeter has adequately served its intended industrial applications for many years, it has always been a device of intermediate accuracy (1.0 percent to 5.0 percent of full scale). Recent innovations in thermal flow sensor design and computational algorithms have created a paradigm shift in thinking about thermal dispersion technology performance possibilities. For example, thermal dispersion technology is now capable of measurement accuracy of 0.5 percent of reading above 50 percent of full scale flow. This is far beyond what had been thought possible by engineers. High accuracy is important for users because it improves the quality of their product and, in the case of custody transfer, saves them money. Next-generation thermal meters now compete with the accuracy of Coriolis meters on gas applications, at a fraction of the installed cost, and with much lower pressure drop.

Flow Sensor Innovation—Four Sensors Instead of Two

In the traditional "two-sensor" flowmeter, the heat lost via stem conduction is not accounted for. This can introduce errors as high as 20 percent, depending on the gradient between the gas temperature and the temperature outside of the pipe. The new "four-sensor" design solves this problem by adding two more sensors to the traditional flow sensor seen in Figure 1.

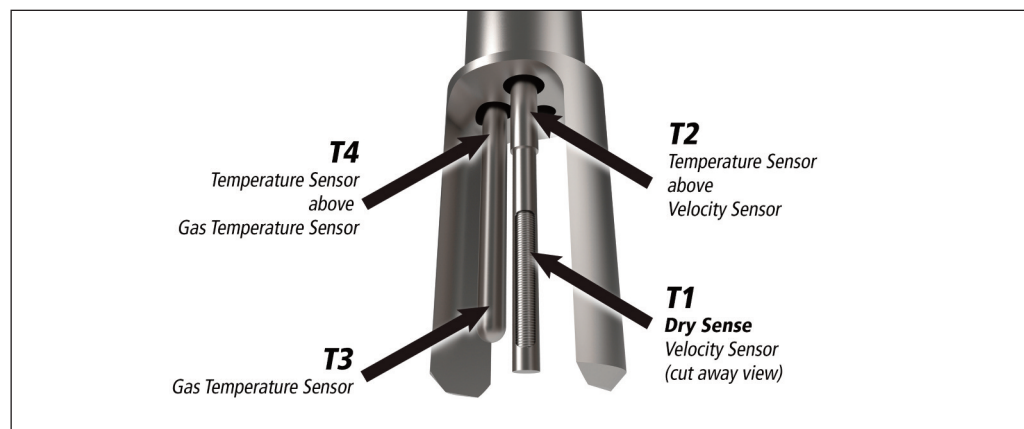

Figure 2. New QuadraTherm "Four-Sensor" Thermal Dispersion Flow Sensor

As shown in Figure 2, two new temperature sensors (T4 and T2) are added to the two-sensor design (T3 temperature and T1 velocity) used in traditional flowmeters. T4 and T2 provide real-time measurement of stem conduction and the heat lost to the outside environment. This innovation is mainly responsible for the paradigm shift in accuracy offered by the advanced flowmeter.

Sensor Stability — "Dry" Sensor Technology

Another inherent weakness of traditional flowmeters is change in the "skin resistance" (the resistance to heat flow of a given material) in the velocity sensor. Since the heat must flow from the heated section of the velocity sensor through a potting compound and then through the tubular metal sheath to reach the boundary layer, any change in this thermal resistance over time will degrade the accuracy of the flowmeter. In a traditional "wet" sensor, the heated velocity sensor element is inserted into the tip of tubular metal sheath and then is surrounded by potting compounds, such as epoxy, ceramic cement, thermal grease, or alumina powder. Such sensors are difficult to manufacture reproducibly, which ultimately leads to reduced accuracy. Even worse, long-term measurement errors are caused by the aging and cracking of the potting compound due to the differential thermal expansion between the parts of the velocity sensor.

As shown in Figure 3, a swaging process is used to eliminate all air gaps between the heated velocity sensor element and the tubular sheath. Furthermore, the special alloy tubular sheath, the wire-wound RTD, and its mandrel all have closely matched coefficients of thermal expansion, so that temperature changes do not cause stresses within the velocity sensor. This results in increased sensitivity, reproducibility, and immunity to cracking and shifting over time, and ultimately to improved accuracy and reliability.

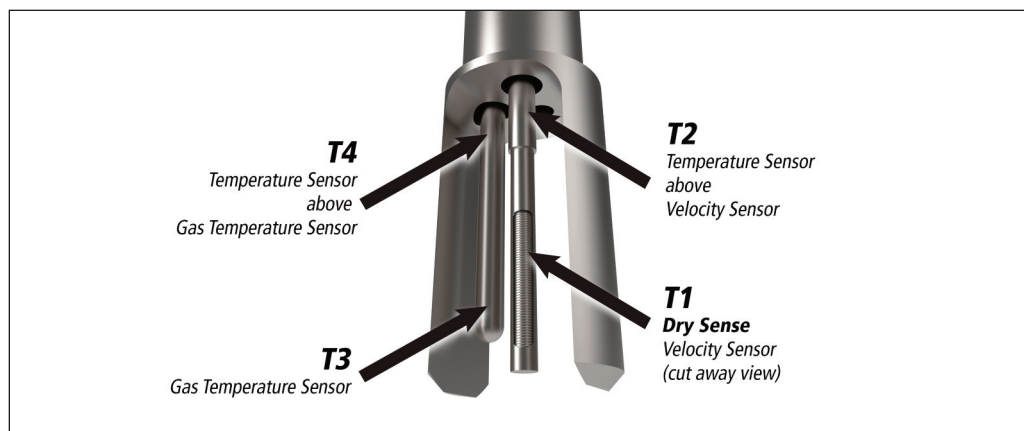

Figure 3. DrySense Velocity Sensor

Advancements in Microprocessor-Based Flow Measurement

In traditional thermal dispersion mass flowmeters, a Wheatstone bridge (either analog or digital) is used by the electronics to maintain the set-point constant differential temperature ΔT . Such an approach has inherent weaknesses:

- Resolution becomes limited at high flow rates;
- Changes in gas properties due to changes in process temperature and pressure are not directly accounted for; and
- The meter is accurate only for the specific gas, the specific pipe, and the narrow ranges of gas temperature and pressure for which the meter was flow-calibrated.

New advancements in thermal dispersion technology described here replace the traditional bridge circuit with a powerful microprocessor that runs a comprehensive flow-measurement algorithm. This algorithm uses the dry sensor technology and inputs from the four temperature sensors to solve the first law of thermodynamics in a fraction of a second for each mass flow data point. This allows the meter to manage changes in:

- Gas mass flow rate
- Gas temperature
- Gas pressure
- Outside temperature
- Pipe conditions (size and roughness)
- Flow profile

This algorithm calculates stem conduction and all other unwanted heat-transfer components, subtracts them from the measured electrical power input, and then computes the mass flow rate from the remaining forced convection component. This leads to unprecedented flexibility in the field.



A New Paradigm

Since the publication of the ASME standard¹, advancements in thermal dispersion mass flow technology have occurred. Among these advancements include:

- Multivariable measurements of mass flow rate, gas temperature, and gas pressure
- Management of dynamic changes in gas temperature, gas pressure, and outside temperature
- Flexibility in the field to select a different process gas, gas mixture, pipe size, and flow profile, as well as other application details
- High stability (10 years)
- Higher mass flow rates
- Immunity to upstream flow disturbances via a built-in flow conditioner
- Accuracy of 0.5 percent of reading for flow rates above 50 percent of the full scale flow rate

Thermal dispersion technology has finally reached its potential to deliver the accuracy and flexibility the industry has long been seeking.

References

1. ASME MFC-21.2-2010. Measurement of fluid flow by means of thermal dispersion mass flowmeters. <http://www.asme.org/products/codes---standards/measurement-of-fluid-flow-by-means-of-thermal-disp>
2. King, L.V. 1914. On the convection of heat from small cylinders in a stream of fluid: Determination of the convection constants of small platinum wires with application to hot-wire anemometry. *Phil. Trans. Roy. Soc. A214*: 373-432.

Trademarks

1. QuadraTherm is a registered trademark of Sierra Instruments, Inc.
2. DrySense is a trademark of Sierra Instruments, Inc.

Figure 4.
QuadraTherm
640i / 780i
Mass Flow Meters
by Sierra



About the Author

John G. Olin, Ph.D., is the founder and chairman of Sierra Instruments, Inc., located in Monterey, Calif. Dr. Olin received his bachelor's degree from Illinois Institute of Technology and his master's and Ph.D. from Stanford University, all in Mechanical Engineering. At Stanford, Dr. Olin specialized in fluid mechanics and heat transfer and used thermal flow meters in research pursuant to his doctoral dissertation. He founded Sierra Instruments in 1973 with the purpose of offering thermal mass flowmeters to solve industry's need for accurate, reliable flowmeters based on the thermal principle. Dr. Olin has a dozen patents and over 60 papers in the field.