

Sierra 810 Series Mass-Trak® Mass Flow Instruments



Instruction Manual

Part Number: IM-81

Revision D.5 11/10



GLOBAL SUPPORT LOCATIONS: WE ARE HERE TO HELP!

CORPORATE HEADQUARTERS

5 Harris Court, Building L Monterey, CA 93940
Phone (831) 373-0200 (800) 866-0200 Fax (831) 373-4402
www.sierrainstruments.com

EUROPE HEADQUARTERS

Bijlmansweid 2 1934RE Egmond aan den Hoef
The Netherlands
Phone +31 72 5071400 Fax +31 72 5071401

ASIA HEADQUARTERS

Rm. 618, Tomson Centre, Bldg A, 188 Zhang Yang Road
Pu Dong New District, Shanghai, P.R. China
Phone: + 8621 5879 8521 Fax: +8621 5879 8586

IMPORTANT CUSTOMER NOTICE: OXYGEN SERVICE

Sierra Instruments, Inc. is not liable for any damage or personal injury, whatsoever, resulting from the use of Sierra Instruments standard mass flow meters or controllers for oxygen gas. You are responsible for determining if this mass flow meter or controller is appropriate for your oxygen application. You are responsible for cleaning the mass flow meter or controller to the degree required for your oxygen flow application.

© COPYRIGHT SIERRA INSTRUMENTS 2010

No part of this publication may be copied or distributed, transmitted, transcribed, stored in a retrieval system, or translated into any human or computer language, in any form or by any means, electronic, mechanical, manual, or otherwise, or disclosed to third parties without the express written permission of Sierra Instruments. The information contained in this manual is subject to change without notice.

TRADEMARKS

Max-Trak[®] 810 Series is a Registered Trademark of Sierra Instruments, Inc. Other product and company names listed in this manual are trademarks or trade names of their respective manufacturers.

TABLE OF CONTENTS

Chapter 1 Introduction

Introduction.....	1-1
Using this Manual.....	1-2
Safety Information	1-3
Receipt of System Components	1-3
Technical Assistance	1-3
The 810 Series Flow Sensing Principle	1-4

Chapter 2 Installation

Installation Overview.....	2-1
Before Beginning an Installation.....	2-1
Installing the Transducer (Plumbing)	2-2
Compression Fittings	2-2
VCO Fittings	2-3
VCR Fittings.....	2-3
1/4-inch Female NPT Fittings	2-3
Installing the Transducer (Electrical)	2-4
D-connector PIN assignments.....	2-5

Chapter 3 Operation

Mass Flow Meter Operation	3-1
Mass Flow Controller Operation.....	3-1
Setpoint Adjustment.....	3-2
Setpoint Configuration.....	3-3
Over-Range Condition	3-4
Auto Shut-Off Function	3-5
Manual Valve Override	3-5
ValvePurge.....	3-5

Chapter 4 Maintenance

Flow Path Maintenance and Cleaning	4-1
Sensor Maintenance and Inspection	4-2
Valve Maintenance	4-3
Valve Adjustment Procedure	4-4
Transducer Calibration	4-5

Chapter 5 Troubleshooting

Transducer Troubleshooting Charts.....	5-1
Returning Equipment to the Factory	5-2

Appendix A Conversion Formulas and Gas Tables

Calculations.....	A-1
Gas Tables with K-factors	A-5

Appendix B Product Specifications

Operating Specifications	B-1
Performance Specifications	B-2
Physical Specifications	B-2
Mounting Dimensions (Nylon Body)	B-3
Dimensions—Stainless Steel Low Flow Body.....	B-4
Dimensions—Stainless Steel Medium Flow Body	B-5

Appendix C Pin Connections

Appendix D Purge and Valve Off Connections

List of Figures

1-1. Mass-Trak Features (Typical)	1-1
1-2. Flow Paths through the Transducer	1-4
1-3. Flow Measuring Principle	1-4
1-4 Sensor Temperature Distribution	1-5
1-5 Linear Range of Transducer Output Signal	1-5
2-1. Minimum Restriction Diameters	2-4
2-2. Transducer D-Connector Pin Assignments	2-5
3-1 Dip Switch Settings.....	3-3
4-1. Stainless Steel Low Flow Internals.....	4-2
4-2. Stainless Steel Medium Flow Internals.....	4-2
4-3. Nylon Transducer Internals.....	4-2

Chapter 1 Introduction

Sierra's Mass-Trak mass flow meters and controllers are designed to accurately measure and control flows of process gases. This instruction manual covers the installation, operation and maintenance of the Mass-Trak product line, which includes the following Sierra models:

- Model 810M Mass-Trak Flow Meter
- Model 810C Mass-Trak Flow Controller
- Model 810S-L Mass-Trak Flow Controller for flows up to 15 SLPM
- Model 810S-M Mass-Trak Flow Controller for flows from 15 to 100 SLPM

All of these models can be ordered with or without a digital display.

Sierra Instruments' Series 810 Mass-Trak products can be calibrated to measure and control the mass flow rate of gases in several ranges from 0-10 standard cubic centimeters per minute (SCCM) to 0-100 standard liters per minute (SLPM). Accuracy is $\pm 1.5\%$ of full scale over a wide temperature and pressure range, and time response is 5 seconds to within 2% of set point. Detailed product specifications may be found in Appendix B.

Mass -Trak Design (typical)

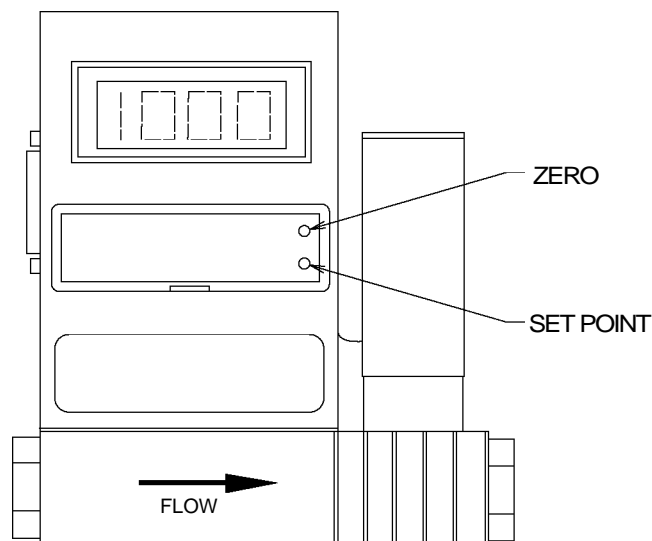

Figure 1-1. Mass-Trak Design (typical)

Mass-Trak is ideally suited to a wide range of gas flow applications including general process control, laboratories, instrument OEM's, gas panels, and flow calibration.

Mass-Trak requires a regulated 24 VDC external power source. The 0-5 VDC and 4-20 mA output signals, which are linearly proportional to gas mass flow rate, are provided for recording, data logging, or control. A 15-pin "D" connector is provided for power input, output signal and set point control. Mass-Trak is available in a variety of configurations with either a nylon or stainless steel flow body. A 24VDC power supply is available as an option.

Using This Manual

This manual is organized into five chapters:

- Chapter 1 includes the introduction and theory of operation
- Chapter 2 provides installation, plumbing and wiring instructions
- Chapter 3 describes operation and features
- Chapter 4 covers routine maintenance
- Chapter 5 contains the troubleshooting guide and service recommendations

There are also 4 Appendices:

- Appendix A lists conversion formula and gas tables
- Appendix B includes the product specifications, dimensional drawings and mounting instructions
- Appendix C describes the PIN connections
- Appendix D describes the purge and valve off connections

Throughout this manual, we use the word *transducer* as a generic term to represent all models of Sierra's 810 Series Mass-Trak instruments.

Safety Information

Caution and warning statements are used throughout this book to draw your attention to important information.



Warning!

This statement appears with information that is important to protect people and equipment from damage. Pay very close attention to all warnings that apply to your application.



Caution!

This statement appears with information that is important for protecting your equipment and performance. Read and follow all cautions that apply to your application.

Receipt of System Components

When receiving a Sierra transducer, carefully check the outside packing carton for damage incurred in shipment. If the carton is damaged, notify the local carrier and submit a report to the factory or distributor. Remove the packing slip and check that all ordered components are present and match your specifications (as ordered). Make sure any spare parts or accessories are not discarded with the packing material. Do not return any equipment to the factory without first contacting Sierra Customer Service.

Technical Assistance

If you encounter a problem with your transducer, review the configuration information for each step of the installation, operation and set up procedures as explained in this manual. Verify that your settings and adjustments are consistent with factory recommendations. Refer to Chapter 5, Troubleshooting, for specific information and recommendations.

If the problem persists after following the troubleshooting procedures outlined in Chapter 5, contact Sierra Instruments by fax or by E-mail (see inside front cover). For urgent phone support you may call (800) 866-0200 or (831) 373-0200 between 8:00 a.m. and 5:00 p.m. PST. In Europe contact Sierra Instruments by at +31 72 5071400. When contacting Technical Support, make sure to include this information:

- The flow range, serial number, Sierra order number and model number (all marked on the transducer nameplate)
- The problem you are encountering and any corrective action taken
- Application information (gas, pressure, temperature, pipe and fitting configuration)

The 810 Mass -Trak Flow Sensing Principle

The operating principle of Mass-Trak transducers is based on heat transfer and the first law of thermodynamics. During operation process gas enters the instrument's flow body, where it encounters the laminar flow bypass. The laminar flow bypass generates a pressure drop, $P_1 \sim P_2$, forcing a small fraction of the total flow to pass through the sensor tube (\dot{m}_1). The remainder of the flow continues through the body (\dot{m}_2). (Figure 1-2)

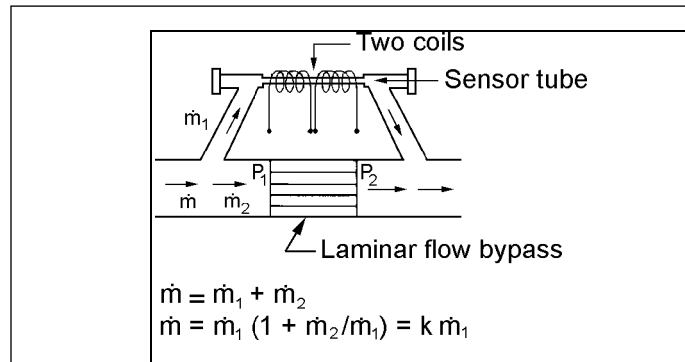

Figure 1-2. Flow Paths through the Transducer

Two resistance temperature detector (RTD) coils around the sensor tube direct a constant amount of heat (H) into the gas stream. In actual operation, the gas mass flow carries heat from the upstream coil to the downstream coil. The resulting temperature difference (ΔT) is detected by the RTD coils and gives the output signal. Since the molecules of the gas carry away the heat, the output signal is linearly proportional to gas mass flow. (Figure 1-3)

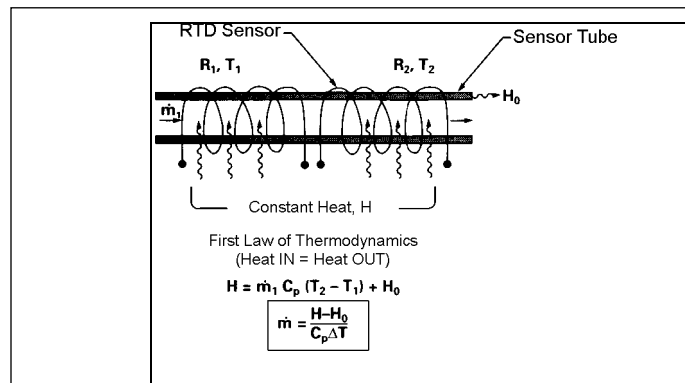

Figure 1-3. Flow Measuring Principle

Figure 1-3 shows the mass flow through the sensor tube as inversely proportional to the temperature difference of the coils.

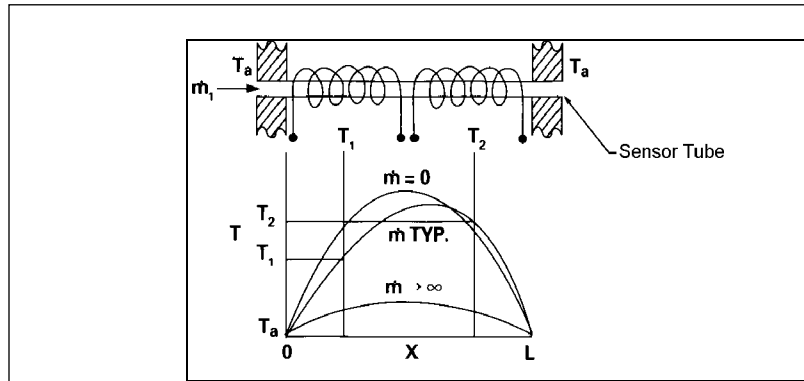

Figure 1-4. Sensor Temperature Distribution

The RTD coils are legs of a bridge circuit with an output voltage in direct proportion to the difference in the coils' resistance; the result is the temperature difference (ΔT), Figure 1-4. Two other parameters, heat input (H) and coefficient of specific heat (C_p) are both constant. The resulting output is nearly linear over the transducer's normal operating range (Figure 1-5).

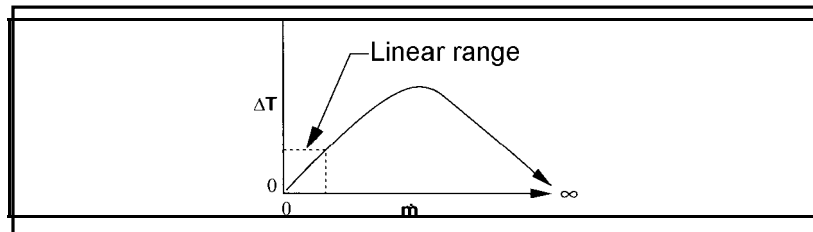

Figure 1-5. Linear Range of the Transducer's Output Signal

For mass flow *controllers*, once the gas flows through the monitoring section, it is then controlled by the built-in servo-control valve. All models of the Mass-Trak utilize Sierra's proprietary high-efficiency Fast-Trak Electromagnetic Valve. The normally closed Fast-Trak valve is similar to an on/off solenoid valve, except that the current to the valve coil, and hence the magnetic field, is modulated so that the ferromagnetic valve armature, or valve plug, assumes the exact height above the valve's orifice required to maintain the valve's command flow. The result is nearly infinite resolution.

Chapter 2 Installation

Installation Overview

Mass-Trak transducers are supplied with female NPT, compression, VCO, or VCR process connections. To ensure a successful installation, inlet and outlet tubing should be in a clean state prior to plumbing the transducer into the system. The shipping caps covering the inlet/outlet fittings should not be removed until immediately prior to installation.

Before Beginning the Installation

Before installing the transducer, verify the following:

1. Ensure that the installation site conforms to the specific operating parameters recorded on the transducer's nameplate. This is critical as each transducer is factory-configured for a specific gas and flow range, pressure differential, temperature range and mounting orientation. The line pressure should not exceed the upper limit for the model in hand: 150 psig (Models 810M, 810C), 500 psig (Model 810S-M) or 1000 psig (Model 810S-L). The temperature should not exceed 122°F (50°C).
2. Double-check to be sure that the transducer o-ring material is compatible with the gas to be measured.
3. If the gas contains any particulate matter, install an in-line filter upstream of the transducer. Recommended filter size: 15 micron for flows of 10 to 30 slpm, 30 micron for flows above 30 slpm.
4. Do not locate the transducer in areas subject to sudden temperature changes, excessive moisture, frequent drafts or near equipment radiating significant amounts of heat. Be sure to allow adequate space for cable connectors and wiring.
5. Ensure the installation location provides a minimum of two inches of straight pipe upstream and downstream from the process connections.
6. For controllers, use a properly sized pressure regulator and verify that the controller orifice size is the smallest in the system. There can be no restrictions (such as valves, tubing or pipe internal diameters, reducers, etc.) upstream or downstream of the controller with a dimension that is less than the valve orifice diameter.
7. Output Signals: The Mass-Trak has 0-5 VDC (0-10 VDC optional) and 4-20 mA output signals that are linearly proportional to the gas mass flow rate. The instrument was calibrated using either voltage or current output as specified on the data tag. Note that there may be a slight difference between the voltage and the current output signals (up to

- 1 %). Using the output that is recorded on the data tag will optimize instrument performance.
8. **Integral Display:** The 3 1/2 digit LCD display reads directly in engineering units or percent of full scale. The full-scale range and gas are shown on the instrument data tag. The decimal point for the flow rate is set at the factory and will show automatically (e.g., "5.54" SLM or "76.4" %).
 9. Over range conditions are indicated by the display and/or output going to a high level, approximately 150% of the full-scale range. After the over-range condition has been removed, it may take several minutes for the Mass-Trak to recover and resume normal operation.
 10. The transducer has stringent power supply requirements. Because the valve on flow controllers is operated in a control loop, power supply variations cannot be tolerated. See Appendix B for a complete listing of power requirements.

Installing the Transducer-Plumbing

Follow the installation instructions that are applicable to your transducer's process connection. Before use, all plumbing should be checked carefully for leaks and the transducer should be purged with dry nitrogen. Ensure that the tubing is free from burrs, or sharp rims that may result from cutting.



Caution!
Only qualified personnel should install the transducer.

CAUTION: All instruments are leak-tested prior to shipping. To check your installation, test the fittings only. Do not use liquid leak detectors such as Snoop® to search for leaks inside or outside the Mass-Trak. Instead, monitor pressure decay.

Compression Fittings

1. Position the transducer with the flow direction arrow pointing in the direction of flow.
2. Verify the position of the front and back ferrule as shown above. Insert the tubing into the fitting. Be sure that the tubing rests firmly on the shoulder of the fitting and that the nut is finger-tight. Scribe the nut at the six o'clock position.
3. While holding the fitting body steady with a backup wrench, tighten the nut 1-1/4 turns, watching the scribe mark make one complete revolution and continue to the nine o'clock position. For 1/16-inch, 1/8-inch and 3/16-inch (2, 3 and 4 mm) sizes, tighten only 3/4 turns from finger-tight. Do not over-tighten!

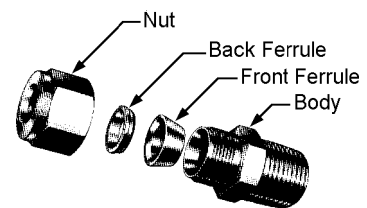

4. Check the system's entire flow path thoroughly for leaks. (Do not use liquid leak detectors. Instead, monitor pressure decay. Exposing the transducer to leak detector fluid may damage the unit.)

VCO Fittings

1. Position the transducer with the flow direction arrow pointing in the direction of flow.
2. Tighten the nut finger-tight, and then 1/4 turn tighter with a wrench. Do not over-tighten!
3. Check the system's entire flow path thoroughly for leaks. (Do not use liquid leak detectors. Instead, monitor pressure decay. Exposing the transducer to leak detector fluid may damage the unit.)

VCR Fittings

1. Position the transducer with the flow direction arrow pointing in the direction of flow.
2. Install new washers that are compatible with the gas to be used.
3. Tighten the nut finger-tight, and then 1/4 turn tighter with a wrench. Do not over-tighten!
4. Check the system's entire flow path thoroughly for leaks. (Do not use liquid leak detectors. Instead, monitor pressure decay. Exposing the transducer to leak detector fluid may damage the unit.)

1/4 inch Female NPT (standard on nylon flow bodies)

1. Position the transducer with the flow direction arrow pointing in the direction of flow.
2. Use a good quality paste pipe thread sealant. Apply to the inlet and outlet fittings.
3. Tighten the fittings by hand. Then, tighten no more than 1 turn. Caution! Do not over-tighten. Damage to the instrument may result from over-tightening fittings.

IMPORTANT—Straight-run requirement (critical for nylon flow body instruments)

Install a section of straight pipe at least five pipe diameters in length upstream of the transducer. DO NOT use reducers. In the case of a flow meter, at least two pipe diameters downstream are required for optimum performance. In the case of a flow controller, there can be no restrictions (such as valves, tubing or pipe internal diameters, reducers, etc.) upstream or downstream of the MFC with a dimension that is less than the valve orifice diameter. Failure to comply with this requirement will result in severely impaired performance and possible oscillations in flow controllers. Refer to Table 2-1 below for minimum restriction diameters upstream or downstream of the flow controller.

Flow Ranges Relative to N2	Valve Orifice Diameter (Typical-in inches)
0-10 to 0-2000 SCCM	0.020
0-2 to 0-11 SLM	0.040
0-11 to 0-22 SLM	0.055
0-15 to 0-28 SLM	0.063
0-20 to 0-50 SLM	0.073
0-51 to 0-73 SLM	0.094
0-61 to 0-100 SLM	0.110

Table 2-1 Typical Minimum Restriction Diameters (Under Standard Pressure Conditions of 30 PSIG Inlet and Ambient Outlet)

Installing the Transducer—Mechanical Mounting

Please refer to Appendix B for mechanical mounting instructions.

Installing the Transducer—Electrical Connections



Caution!

The transducer is not a loop-powered device! Do NOT apply power to the 4-20 mA output or input connections.

The Mass-Trak transducers require a 24VDC power supply. If you are using the Power-Pak power supply, connect it to the 15-pin "D" connector on the side of the transducer. If you are supplying your own power source, it must be a regulated 24 VDC with ripple not to exceed 100 mV peak-to-peak and capable of producing at least 340 mA (8 watts).

Mass-Trak is provided with a 15-pin "D" connector located on the side of the enclosure. The pin numbers and assignments for the Mass-Trak "D" connector are shown in Figure 2-2. The connections for input power, output signal and input signal (controllers only) are supplied via the "D" connector. Additional pin assignments can be found in Appendix C.

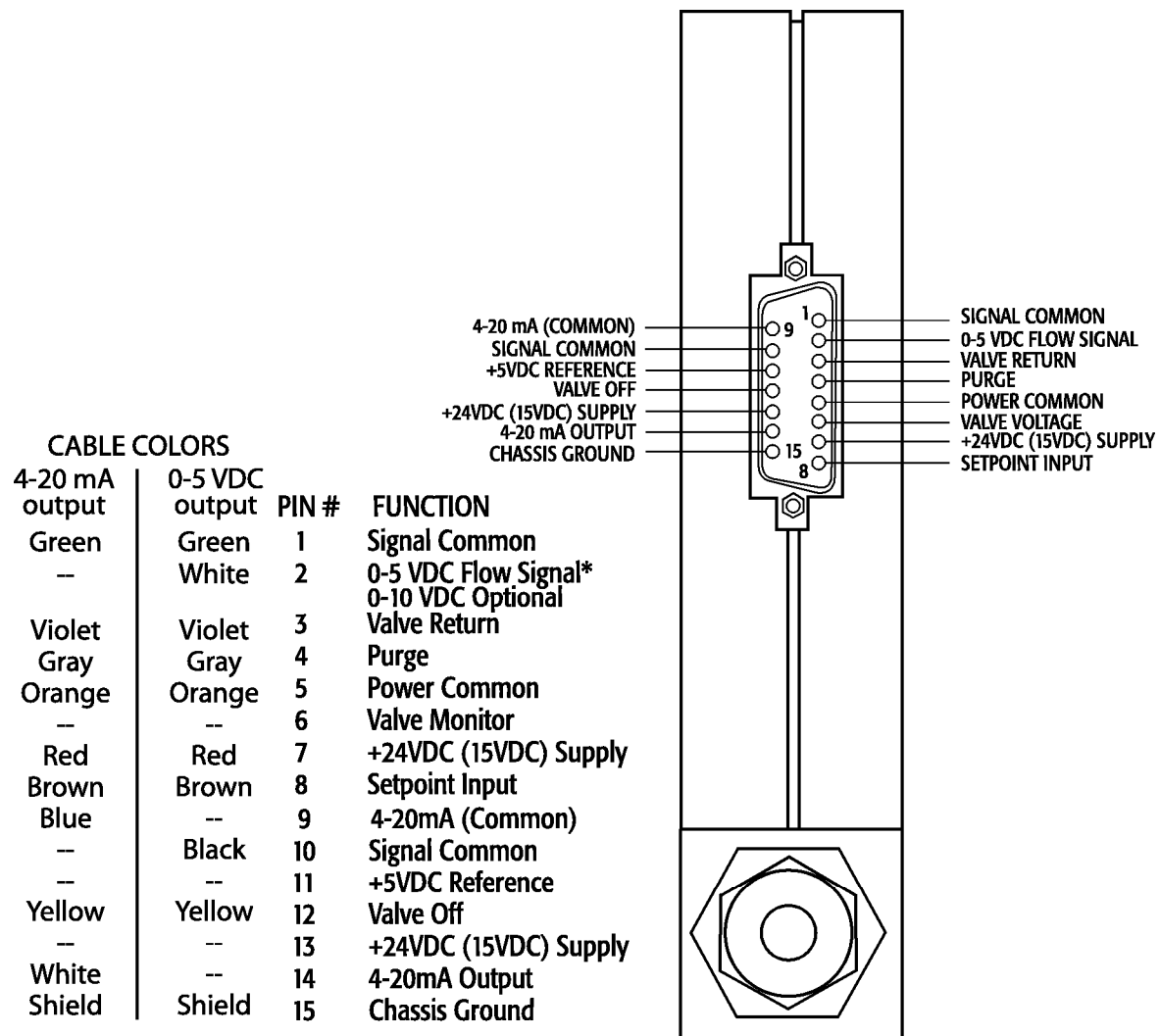

Note: Pins 1, 3, 5, 9 and 10 are all tied together internally. However it is highly recommended that at least one "signal common", one "power common" and the "valve return" pins be connected to the power supply common via separate wires, so that no ground loops are introduced, (especially on cables longer than ten feet)

Figure 2-2. Transducer D-Connector Pin Assignments

Chapter 3 Operation

This chapter covers transducer operation and controller features available on Sierra's Mass-Trak models.

Standard output for all transducers are linear 0-5 VDC (0-10 VDC optional) and 4-20 mA output signals corresponding to 0 to 100% of the mass flow full-scale range. For mass flow controllers, an input signal of 0-5 VDC (0-10 VDC optional) or 4-20 mA, or use of the local set-point control, allows users to set the gas flow rate to any desired value within the range of the model. This input signal is a direct linear representation of 0 to 100% of the mass flow full-scale value.

Mass Flow Meter Operation (see below for Controllers)

After the transducer is installed and the system has undergone a complete leak check, follow these steps:



Caution!

The Mass-Trak is not a loop-powered device. Do not apply power to the 4-20 mA sections.

1. Apply power to your Mass-Trak using Sierra's power supply or your own input power source. When power is first applied, the output signal will remain at a high level until the sensor reaches its normal operating temperature range. This requires approximately 20 seconds, after which time (assuming no gas flow is present) the signal and display will drop to 0 VDC (or 4 mA). Allow at least an additional 15 minutes of additional warm-up time before performing any other performance checks or adjustments.
2. Perform an initial zero output check (required for first-time start ups only). Make certain there is no gas flowing through the instrument. If the input pressure listed on the instrument data label is atmospheric, turn on the meter and confirm that the display reads zero +/- 1.5% of full scale and that the output reads zero +/-0.075V or +/-0.24mA. If the reading exceeds these limits, you may adjust the zero potentiometer (located on the front panel—see Figure 1-1 in Chapter 1). Turning the potentiometer screw clockwise increases the zero. If the inlet pressure listed on the data label is greater than atmospheric, apply gas pressure to the instrument's inlet and block off the outlet in order to obtain the recorded static pressure. If necessary, adjust the zero as above.
3. Open the gas supply. Mass-Trak will begin monitoring the gas mass flow rate.

Mass Flow Controller Operation

After the transducer is installed and the system has undergone a complete leak check, follow these steps:

1. Ensure the set point is zero before applying power. If the setpoint input is not connected to some type of command control device, DIP switch #1 must be in the "internal source" position or the valve-off function must be activated (see Setpoint Adjustment and Configuration section

below). **Note: If no setpoint command is present on a controller when powered-up and the valve is not switched off, the valve may drift wide open.** (The valve will open momentarily when power is first applied).

2. Apply power to your Mass-Trak using Sierra's power supply or your own input power. When power is first applied, the output signal will remain at a high level until the sensor reaches its normal operating temperature range. This requires approximately 20 seconds, after which time (assuming no gas flow is present) the signal and display will drop to 0 VDC (or 4 mA). Allow at least 15 minutes of additional warm-up time before performing any other performance checks or adjustments.
3. Perform an initial zero output check (required for first-time start-ups only). Make certain there is no gas flowing through the instrument. Confirm that the display reads zero + 1.5% of full-scale and that the output signal is less than + 0.075 VDC or + 0.24 mA (this is maximum allowable within the accuracy specification of the transducer). If the reading exceeds these limits, you may adjust the zero potentiometer (located on the front panel—see Figure 1-1 in Chapter 1). Turning the potentiometer screw clockwise increases the zero.
4. Open the gas supply. Mass-Trak will begin monitoring the gas mass flow rate
5. Adjust the controller set point to the desired flow rate. The effective control range of the unit is 10% to 100% of the calibrated full scale flow range. Below 2%, the control valve will automatically shut off the flow unless this function is disabled (see below).

Mass Flow Controller Features

Setpoint Adjustment

The setpoint input signal is a direct linear representation of 0-100% of the mass flow full-scale value. A 0 VDC (or 4 mA) set point will regulate the flow to 0% and a 5.00 VDC (20 mA) set point will adjust the flow to 100% of the instrument's calibrated range.

The setpoint signal may be applied externally or internally. If you wish to use the internal setpoint potentiometer, it may be accessed through the front panel. Turning the potentiometer clockwise increases the setpoint. Either 0-5 VDC (0-10 VDC optional) or 4-20 mA external setpoint commands are available through the D-connector. See Appendix C for wiring details.

When the command (setpoint) signal is applied, the flow controller will respond to changes in the setpoint within six seconds to $\pm 2\%$ of full scale of the selected flow rate.

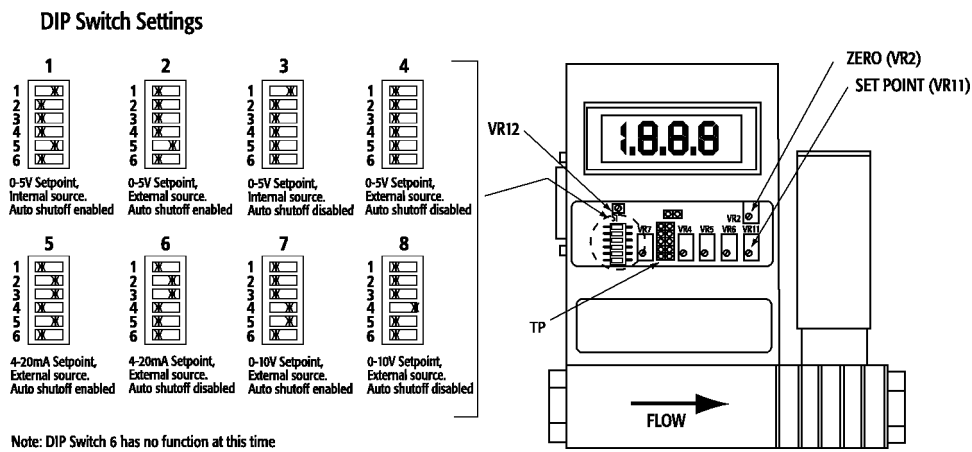

Figure 3-1 Component Location and DIP Switch Set-up of Mass-Trak

Setpoint Configuration (see Figure 3-1)

The DIP switches located behind the front panel on the Mass-Trak flow controllers are used to configure setpoint operation and the Automatic Shut-Off feature. The DIP switches are not enabled on the 810M flow meter.

All Mass-Trak controllers are set at the factory with the automatic shut off enabled. However, there is no default configuration for the set points. Each instrument is configured at time of calibration to the customer's specific requirements. Setpoint options include the on-board setpoint potentiometer (accessible through a hole in the front panel), or externally sourced 0-5 VDC or 4-20 mA setpoint. A factory installed option of 0-10 VDC input and output is also available. Consult factory if you are interested in the configurations for this special option.

Move DIP switch 1 to the right (ON) to select the internal on-board setpoint potentiometer. Move this switch to the left (OFF) to select an external setpoint. This is also the position required if you choose to use a local setpoint potentiometer.

Move DIP switches 2 and 3 to the right to select 4-20 mA setpoint input. Move these switches to the left to select 0-5 VDC setpoint.

DIP switch 4 is for use with the special-order 0-10 VDC option. Consult the factory for more information.

Move DIP switch 5 to the right to force the controller valve closed (auto shut-off) whenever the setpoint is less than 2% of full-scale. Move this switch to the left to disable the auto shut-off function. Remember that the valve on the Mass-Trak controllers is not a positive shut-off type.

A 5.1 VDC reference is provided for internal and external setpoint command pots. The reference provides approximately 0.125 volts headroom to allow for external cabling and ensures that the instrument will always reach full scale when using these inputs.

DIP switch 6 has no function at this time.

Over-Range

If the flow rate exceeds the full-scale range listed on your Mass-Trak's data label, the output signal and digital display will read a value above full-scale. The Mass-Trak has not been calibrated for over-ranged flows and will be both non-linear and inaccurate if an over-range condition exists. The 0-5 VDC (0-10 optional) and 4-20 mA outputs can exceed full scale by as much as 50%, or more. On the digital display, the display cannot exceed the four digits 1999. If the flow rate exceeds 1999, the right-most digits will appear blank and only the left-hand "1" will appear on the display.

Once the over-range condition has been removed, it may take several minutes for the Mass-Trak to recover and resume normal operation. An over-range condition will not harm the instrument.

Cold Sensor Lockout Circuit

Mass-Trak controllers incorporate a safety circuit that closes the valve when a fault condition is detected that could result in uncontrolled flow (valvewide open). The circuit operates by monitoring the temperature of the sensor elements and forcing the output high if the temperature falls below a preset limit. There are several conditions under which this may occur:

1. Operation at a temperature below that for which the instrument is rated.
2. Power failure while running at or near full-scale. Upon resumption of power, the valve will remain closed until the minimum operating temperature is reached.
3. A rapid, uncontrolled increase of gas flow through the transducer can create a cooling effect on the sensor, driving it below the preset limit. One possible scenario where this may occur is if backpressure downstream from the instrument is suddenly reduced. Another scenario is if the gas pressure should suddenly go to zero while the set point remains at a fixed position. This could occur if a valve upstream is closed, for example. When the pressure is re-instated, a rapid, uncontrolled gas flow could occur activating the cold sensor lockout circuit.

4. Sensor failure.

The cold sensor lockout circuit is enabled during initial start-up. Its operation may be checked by observing the output signal or the LCD display (on models so equipped). The output signal or display will read high for the first 10 to 20 seconds. After that, assuming zero flow, the output will drop to 0 VDC or 4mA, depending on which output you are observing. If this occurs, the circuit is working properly.

Controller Auto Shut-Off Function

All flow controllers are normally provided with an Auto Shut-Off feature that closes the valve at a command signal level of 0.5-3% or less of full-scale. On the Mass-Trak, this feature is factory enabled by setting DIP switch 5 to the right to disable this feature, move DIP switch 5 to the left. The valve will then remain open even when the setpoint falls below 2% of full-scale.

Manual Valve Override (Manual Valve On-Off Control)

Manual valve override is provided for all mass flow controllers. This feature is available by connecting a manual on-off switch to the transducer D-connector across pins 3 and 12 (see Appendix D). Normal operation resumes when pin 12 is left floating.

Valve Purge Function of Mass-Trak Controllers

The purge function opens the controller valve completely for the purpose of purging the meter and for quickly flushing unwanted gas from the flow path. When the valve is opened for purging, it allows flows far in excess of the rated full scale of the controller. Because of the uncontrolled nature of the purge function, two conditions must be met before a controller can be purged:

The Manual Valve Override, if it is being used, must be in the ON or open state.

The Auto-Shutoff function cannot be active (the setpoint command signal must be above 2% of full scale or DIP switch 5 must be in the OFF position).

The activation of either the Manual Valve Override or the Auto-Shutoff function will override the purge command.

To activate purge, connect pin 4 of the 15-pin "D" connector to common through either a mechanical switch or an open-collector transistor or logic output capable of sinking at least 4mA (See Appendix D). The maximum voltage appearing on this pin is 5.0 VDC.

Purging Non-Reactive Gases:

Purge the transducer with clean, dry nitrogen for a minimum of two hours.



Caution!
Always fully
neutralize any toxic
gas trapped inside
the transducer
before removing it

Purging Reactive Gases:

One of the following methods may be used:

- Cycle purge. This is done by alternately evacuating and purging the transducer for 2 to 4 hours with clean, dry nitrogen.
- Purge the transducer with clean, dry nitrogen for 8 to 24 hours.
- Evacuate the transducer for 8 to 24 hours.

When toxic or corrosive gases are used, purge unit thoroughly with inert dry gas before disconnecting from the gas line. If a transducer used with a toxic or corrosive gas is returned to the factory, a Material Safety Data Sheet must be enclosed with the unit upon its return.

Chapter 4 Maintenance

Mass-Trak transducers require very little scheduled maintenance. In the event that minor maintenance or adjustment is required, this chapter provides general instructions for:

- Flow Path Maintenance and Cleaning
- Sensor Maintenance and Cleaning
- Valve Maintenance and Adjustment
- Transducer Calibration

Flow Path Maintenance

The transducer flow path should be periodically inspected and cleaned as required. If an in-line filter is used, the filtering element should be replaced periodically or ultrasonically cleaned.

The flow path is made of 316 stainless steel or glass-filled nylon (wetted magnetic parts of the solenoid valve are 430F stainless steel) with Viton®, Neoprene, or Kalrez® (or equivalent) seals, depending on the gas used.

If toxic or corrosive gases are used, purge unit thoroughly with inert dry gas before disconnecting it from the gas line. If a transducer used with a toxic or corrosive gas is returned to the factory, a Material Safety Data Sheet must be enclosed with the unit upon its return.



Caution)

Always fully neutralize any toxic gas trapped inside the transducer before removing from the gas line.

Cleaning the Mass-Trak

After purging (see Chapter 3), carefully remove the transducer from the gas line. You may find a fine-mesh filter screen inside the inlet of the instrument. Inspect the inlet fitting and the filter screen, if there is one, and blow away any particles resting in or adhering to this area with low-pressure compressed air. If the screen appears corroded or damaged it will need to be replaced. Contact the Sierra Instruments Customer Service Department before removing the fittings or the screen, as it is possible to shift calibration of the instrument at this point. If calibration shifts, you will have to return your instrument to an authorized repair center for re-calibration.



Caution)

Do not disassemble the instrument without contacting the Sierra Instruments customer service department.

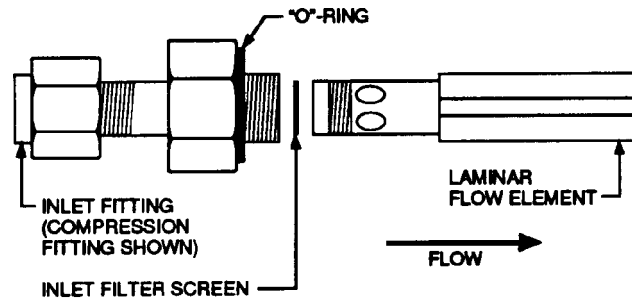

Figure 4-1. Stainless Steel Low Flow Transducer Internals

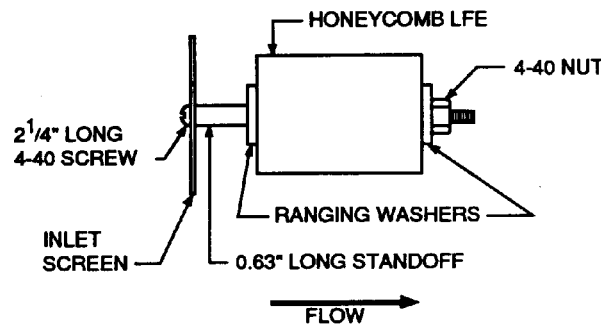

Figure 4-2. Stainless Steel Medium Flow Transducer Internals



Caution!
Do not remove the sensor cover, this could shift transducer calibration.

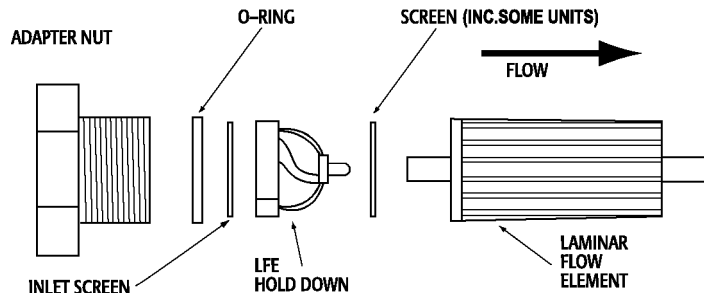

Figure 4-3 Nylon Transducer Internals

Sensor Maintenance

The sensor tube is straight and has a relatively large, 0.031 inch ID. On the nylon flow body instruments, there is no access to the sensor, so any service must be performed by a qualified Service Center. The stainless-steel flow bodies, however, are provided with convenient access ports to make inspection and cleaning easy. Sensor maintenance on these steel-body instruments consists of inspecting and cleaning the sensor flow path.

**Caution!**

When using toxic or corrosive gases, purge the unit with inert dry gas before disconnecting from the gas line.

Sensor Inspection and Cleaning

Cleaning is accomplished by simply rodding out the sensor with the Sensor Cleaning Stylette, available from Sierra for this purpose. To access the sensor for inspection or cleaning:

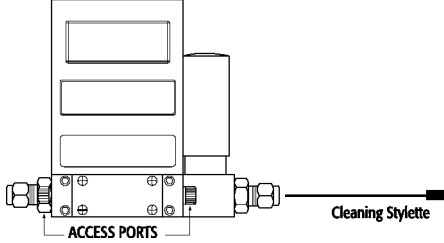
1. Remove the instrument from the system.
 3. Remove the two socket head access port plugs with a 1/4 inch Allen wrench.
- 
3. Visually inspect the sensing ports and sensor. If signs of moisture or corrosion are present, contact the Sierra Instruments Customer Service Department.
 4. Use a hemostat or tweezers to push the cleaning Stylette into the downstream opening of the sensor tube. Move it back and forth inside the sensor tube—DO NOT FORCE, TWIST OR ROTATE.
 5. Flush the sensor tube with a non-residuous solvent. In cases where solids are deposited in sensor, the instrument should be returned to the factory for complete cleaning and re-calibration.
 6. Blow-dry all parts with dry nitrogen and re-assemble.
 7. After the transducer is re-installed in the system, leak test the connection. CAUTION: Do not use liquid leak detectors to search for leaks inside or outside the instrument. Instead, monitor pressure decay.

Valve Maintenance

All Mass-Trak Flow Controllers use the same valve. Other than an occasional cleaning, these electromagnetic valves require no maintenance under normal operating conditions. Opening the valve, using the purge function and flushing in both directions are usually all that is required. If you have reason to believe that additional cleaning is required, do not disassemble the valve. Contact Sierra Instruments' Customer Service Department.

Use of certain corrosive gases may necessitate frequent replacement of the valve seat and O-rings. This problem can be solved by installing the appropriate elastomers in your instrument. Viton® is standard, with Neoprene®, Kal-Rez® (or equivalent), and PFA Teflon® offered as options on the Stainless Steel Flow Bodies.

Valve Adjustment

Mass-Trak controls flow with a proportional electromagnetic valve that is set up for certain process operation conditions. Variables that affect its operation include orifice size, spring selection and adjustment, and input and output pressures. If operating conditions change it may be necessary to make a valve spring adjustment. An adjustment may also be required due to dimpling of the valve seat or spring sag, both of which can cause a change in the internal dimensions of the valve. Please note that performing the following procedure will NOT affect your transducer's calibration and MUST be performed with the instrument installed at normal operating conditions.

An incorrectly adjusted valve can be detected by one of the following symptoms:

- **Leakage at a zero set point**
- **The instrument will not reach maximum flow**
- **The output is unstable**
- **Valve oscillation**

The following valve adjustment procedure can be followed to correct the above conditions. You will need:

- 1/16" hex wrench
- 5/16" nut driver or socket

All controllers should be thoroughly leak-tested following any valve adjustment. CAUTION: Do not use liquid leak detectors to search for leaks inside or outside the instrument. Instead, monitor pressure decay.

Procedure:

If the instrument is experiencing leak-by with a zero setpoint, remove the plastic cover from the top of the solenoid valve, located to the right of the electronics enclosure. Apply inlet and outlet pressures to the controller as recorded on either the data label or Calibration Certificate of your instrument. Loosen the 5/16" locknut (not the large, white, plastic nut, but the smaller one on top of it.) Adjust the center adjustment screw (using a 1/16" hex wrench) slowly, clockwise, 1/8 turn at a time. This increases the spring tension in the valve. Continue until the leak-by subsides. Next, adjust this screw clockwise one half-turn past this point, tighten the locknut and replace the cap. Test the controller operation at various setpoints over its operational range.

If your unit is experiencing one of the other symptoms listed above, remove the small front access door to expose the test points, pots and DIP switches. (see figure 3.1)

TESTPOINT BLOCK (labeled TP in Figure 3.1):

Setpoint	TP10 *	* TP9	Valve +
+5V Reference	TP8 *	* TP7	4-20mA out
0-5 volt out	TP6 *	* TP5	Common
Bias Voltage	TP4 *	* TP3	Test Flow Signal
Sensor Amp	TP2 *	* TP1	Bridge Voltage

1. Connect a voltmeter to test points 9 (Valve +) and 5 (Common) and set the scale for 30 volts or higher.
2. Apply two set points, one at 5% full scale and then one at 100% full scale — either locally or remotely (be sure the dip switches are in the proper positions). Monitor the valve voltage at each point. The acceptable range for the valve voltage is 6 to 18 VDC over these two set points.
3. If the valve voltage is outside of these specifications, loosen the 5/16" lock nut, and adjust the center adjustment screw. Turning clockwise will increase the valve voltage, while turning counterclockwise will decrease it. Adjust slowly, 1/8 turn at a time while monitoring valve performance. When the desired voltage is obtained, the symptoms should disappear and the lock nut can be re-tightened.
4. Re-install the front access door and conduct a final check for leak-by with a zero set point, paying particular attention to the seal on the adjusting screw. Remember to monitor pressure decay only, as liquid leak detectors may damage the instrument.



Caution!
It is important that only qualified personnel calibrated this transducer.

If these adjustments do not restore proper performance to your Mass-Trak, contact Sierra Instruments' Technical Support Department.

Transducer Calibration

Calibration of Sierra's flow meters and controllers requires a calibration standard of at least equal accuracy and preferably an order of magnitude

better than the transducer, and a skilled technician familiar with the Mass-Trak transducer. It is recommended that Mass Trak meters and controllers be returned to the factory for annual calibration.

Sierra Instruments maintains two fully equipped calibration facilities: one at the USA headquarters and the other at the European headquarters. All measuring and test equipment used in the calibration of Sierra transducers is traceable to NIST standards. Sierra is ISO-9001 registered and conforms to the requirements of ANSI/NCSL-Z540 and ISO/IEC Guide 25. If your instrument has been damaged or you simply want to have the transducer re-calibrated, see Chapter 5 or contact the factory for return shipping instructions.

Chapter 5 Transducer Troubleshooting

When you suspect that the transducer is not operating correctly, there are a few simple checks that can be made before taking the unit out of service:

1. Make certain that there are no leaks in the gas line.
2. Check that all cables are connected and are in good condition.
3. Verify that the power supply is in the correct range and properly connected to the transducer.
4. Double check connector pin-outs if replacing another manufacturer's transducer.
5. Verify that the DIP switches are configured correctly for your application.
6. Verify that there is adequate inlet gas pressure to the transducer, that there are no downstream restrictions and that any upstream valves are open to allow sufficient gas flow to reach the instrument.

The following information is provided to help locate the cause of a transducer failure. It is not intended to be an all inclusive repair guide. For most repairs, the unit should be returned to the factory for service.

Problem	Possible Cause	Solution
No output	Clogged sensor	Clean or replace sensor
	PCB defective	Repair or replace PCB
	Inlet filter screen clogged	Clean or replace screen
Unit will not zero	Gas leak	Find and correct leaks
	Internal leak-by condition	Perform valve adjustment
	Application requires high pressure and non-horizontal mounting	Re-zero transducer
	PCB defective	Repair or replace PCB

Controller does not respond to set point	Low or no gas pressure	Set correct gas pressure
	Faulty cable or connector	Correct or replace
	Set point is below 2% of full scale	Increase set point or disable auto shut off circuit
	DIP switches improperly set	Re-configure DIP switches
Flow does not match set point	No gas pressure (or low pressure)	Set correct gas pressure
	Inlet filter screen clogged	Clean or replace
	Out of adjustment	Consult factory
Reads full scale with no flow or with valve shut	Gas Leak	Find and correct leaks
	Defective Sensor	Return to factory for replacement
Out of calibration	Dirty or clogged sensor	Clean or replace sensor
	Change in composition of gas	See K-factor tables
	Gas leak	Find and correct leaks
	PCB defective	Repair or replace PCB
	LFE dirty	Consult factory
	Inlet filter screen clogged	Clean or replace screen
	Reference conditions incorrect	Check reference conditions on data label and correct as required.

Returning Equipment to the Factory

Before returning any transducer to the factory, you must request and complete a Sierra Calibration/Repair Data Sheet. To obtain the data sheet contact Customer Service at:

USA Headquarters
Sierra Instruments
Service Department
5 Harris Court, Building W
Monterey, CA 93940

Ph. (800) 866-0200 or (831) 373-0200
Fx. (831) 373-2414

European Headquarters
Sierra Instruments b.v.
Service Department
Bijlmansweid 2
1934RE Egmond a/d Hoef
The Netherlands

Ph. +31 72 5071400
Fx. +31 72 5071401

When returning a component, make sure to include the completed Calibration/Repair Data Sheet and send the item to the appropriate address above. If an instrument used with any toxic or corrosive gas is returned to the factory, a Material Safety Data Sheet must accompany the instrument.

Appendix A Conversion Formulas and Gas Tables

Calculations For Use with a Pure Gas

The following tables provide K-factors and thermodynamic properties of gases commonly used with mass flow meters and controllers. The purpose of these tables is two-fold:

1. Calibrating an “actual” gas with a reference gas. This is particularly useful if the actual gas is not a common gas or if it is toxic, flammable, corrosive, etc.
2. Interpreting the reading of a flow meter or flow controller that has been calibrated with a gas other than the actual gas.

In applying the tables, the following fundamental relationship is used:

$$Q_1/Q_2 = K_1/K_2 \quad (1)$$

Where:

Q = The volumetric flow rate of the gas referenced to standard conditions of 0°C and 760 mm Hg (sccm or slm),

K = The K-factor defined in equation (6),

()₁ = Refers to the “actual” gas, and

()₂ = Refers to the “reference” gas.

The K-factor is derived from the first law of thermodynamics applied to the sensor tube, as described in Chapter 1:

$$H = \underline{m} \underline{N} \underline{C_p} \underline{\Delta T} \quad (2)$$

Where:

H = The constant amount of heat applied to the sensor tube,

m = The mass flow rate of the gas (gm/min)

C_p = The coefficient of specific heat of the gas (Cal/gm); C_p is given in the Table (at 0°C),

ΔT = The temperature difference between the downstream and upstream coils, and

N = A correction factor for the molecular structure of the gas given by the following table:

Number of Atoms in the Gas Molecule	N
Monatomic	1.040
Diatomic	1.000
Triatomic	0.941
Polyatomic	0.880

The mass flow rate, m , can also be written as:

$$m = \rho Q \quad (3)$$

Where:

ρ = The gas mass density at standard conditions (g/l); ρ is given in the tables (at 0°C, 760 mm Hg).

Furthermore, the temperature difference, ΔT , is proportional to the output voltage, E , of the mass flow meter, or

$$\Delta T = aE \quad (4)$$

where:

a = A constant.

If we combine equations (3) and (4), insert them into equation (2), and solve for Q , we get

$$Q = (bN/\rho Cr) \quad (5)$$

where:

$b = H/aE = a$ constant if the output voltage is constant.

For our purposes, we want the ratio of the flow rate, Q_1 , for an actual gas to the flow rate of a reference gas, Q_2 , which will produce the same output voltage in a particular mass flow meter or controller. We get this by combining equations (1) and (5):

$$Q_1/Q_2 = K_1/K_2 = (N_1/\rho_1 C_{p1})/(N_2/\rho_2 C_{p2}) \quad (6)$$

Please note that the constant b cancels out. Equation (6) is the fundamental relationship used in the accompanying tables. For convenience, the tables give “relative” K -factors, which are the ratios K_i/K_2 , instead of the K -factors themselves. In the tables, the relative K -factor is K_{actual}/KN_2 where the reference gas is the commonly used gas, nitrogen (N_2). The remaining columns give C_p and ρ , enabling you to calculate K_i/K_2 directly using Equation (6). In some instances, K_i/K_2 from the tables may be different from that which you calculate directly. The value from the tables is preferred because in many cases it was obtained by experiment. Sierra calibrates every transducer with primary standards using the actual gas or a molecular equivalent

reference gas. The calibration certificate accompanying the transducer cites the reference gas used.

Example 1:

A transducer is calibrated for nitrogen (N₂), and the flow rate is 1000 sccm for a 5.000 VDC output signal. The flow rate for carbon dioxide at a 5.000 VDC output is:

$$Q_{CO2}/Q_{N2} = K_{CO2}/K_{N2}, \text{ or}$$

$$Q_{CO2} = (0.74/1.000)1000 = 740 \text{ sccm}$$

Example 2:

A transducer is calibrated for hydrogen (H₂), and the flow rate is 100 sccm for a 5.000 VDC output signal. The flow rate for nitrous oxide (N₂O) is found as follows:

$$Q_{N2O}/Q_{H2} = K_{N2O}/K_{H2}, \text{ or}$$

$$Q_{N2O} = (0.71/1.01) 100 = 70.3 \text{ sccm}$$

Note that the K -factors relative to nitrogen must be used in each case.

Calculating Dual Gas Mixtures

Equation (6) is used for gas mixtures, but we must calculate N/C_p for the mixture. The equivalent values of ρ , C_p, and N for a dual gas mixture are given as follows:

The equivalent gas density is:

$$\rho = (m_1 / T_p 1) + (m_2 / T_p 2)$$

Where:

$$\dot{m}_T = \dot{m}_1 + \dot{m}_2 = \text{Total mass flow rate (gm/min),}$$

()₁ = Refers to gas #1, and

()₂ = Refers to gas #2

The equivalent specific heat is:

$$C_p = F_1 C_{p1} + F_2 C_{p2}$$

Where:

$$F_1 = (m_1 / T_p) / (m_T / T_p) \text{ and}$$

$$F_2 = (m_2 / T_p) / (m_T / T_p)$$

The equivalent value of N is:

$$N = (m_1 / T_p) / (m_T / T_p) + 4 (m_2 / T_p) / (m_T / T_p)$$

The equivalency relationships for p , C_p , and N for mixtures of more than two gases have a form similar to the dual-gas relationship given above.

IMPORTANT NOTE ABOUT K-FACTORS:

Please note that if you have a transducer calibrated for a gas such as methane and wish to use the K-factors to measure a gas such as air, the inaccuracy of the measurement can range from ± 5 to 10%. The use of K-factors is, at best, only a rough approximation and should not be used in applications that require a better than ± 5 to 10% accuracy.

It should also be noted that certain gases, in similar “families,” would work exceptionally well with K-factors; however, those instances are only true when similar thermal properties of the gas are present.

Gas Tables and K-factors

Actual Gas	Chemical Symbol	K-factor Relative N2	Cp (Cal/g)	Density (g/l) @ 0°C	Elastomer*O-ring	Valve Seat	Nylon Compatible
Acetylene	C ₂ H ₂	.58	.4036	1.162			
Air		1.00	.240	1.293			
Allene (Propadiene)	C ₃ H ₄	.43	.352	1.787		KR	
Ammonia	NH ₃	.73	.492	.760	NEO	NEO	
Argon	Ar	1.45	.1244	1.782			
Arsine	AsH ₃	.67	.1167	3.478		KR	
Boron Trichloride	BCL ₃	.41	.1279	5.227	KR	KR	
Boron Trifluoride	BF ₃	.51	.1778	3.025		KR	
Boron Tribromide	Br ₃	.38	.0647	11.18		KR	
Bromine	Br ₂	.81	.0539	7.130			NO
Bromine Pentafluoride	BrF ₅	.26	.1369	7.803		KR	NO
Bromine Trifluoride	BrF ₃	.38	.1161	6.108		KR	NO
Bromotrifluoromethane (Freon-13 B1)	CBrF ₃	.37	.1113	6.644			
1,3-Butadiene	C ₄ H ₆	.32	.3514	2.413			
Butane	C ₄ H ₁₀	.26	.4007	2.593	NEO	KR	
1-Butane	C ₄ H ₈	.30	.3648	2.503	NEO	KR	
2-Butane	C ₄ H ₈ CIS	.324	.336	2.503	NEO	KR	
2-Butane	C ₄ H ₈ TRANS	.291	.374	2.503			
Carbon Dioxide	CO ₂	.74	.2016	1.964			
Carbon Disulfide	CS ₂	.60	.1428	3.397			
Carbon Monoxide	CO	1.00	.2488	1.250			
Carbon Tetrachloride	CCL ₄	.31	.1655	6.860		KR	NO
Carbon Tetrafluoride (Freon-14)	CF ₄	.42	.1654	3.926		KR	
Carbonyl Fluoride	COF ₂	.54	.1710	2.945			
Carbonyl Sulfide	COS	.66	.1651	2.680			
Chlorine	CL ₂	.86	.1144	3.163		KR	NO
Chlorine Trifluoride	CLF ₃	.40	.1650	4.125		KR	
Chlorodifluoromethane (Freon-22)	CHCLF ₂	.46	.1544	3.858		KR	
Chloroform	CHCL ₃	.39	.1309	5.326		KR	
Chloropentafluoroethane (Freon-115)	C ₂ CLF ₅	.24	.164	6.892		KR	
Chlorotrifluoromethane (Freon-13)	CCLF ₃	.38	.153	4.660		KR	
Cyanogen	C ₂ N ₂	.61	.2613	2.322		KR	
Cyanogen Chloride	CLCN	.61	.1739	2.742			
Cyclopropane	C ₃ H ₅	.46	.3177	1.877		KR	
Deuterium	D ₂	1.00	.1722	1.799			
Diborane	B ₂ H ₆	.44	.508	1.235		KR	
Dibromodifluoromethane	CB ₂ F ₂	.19	.15	9.362		KR	
Dibromomethane		.47	.075	7.76		KR	
Dichlorodifluoromethane (Freon-12)	CCL ₂ F ₂	.35	.1432	5.395		KR	
Dichlorofluoromethane (Freon-21)	CHCL ₂ F	.42	.140	4.592		KR	

* If no O-ring material is specified then O-ring to be used is Viton. Nylon Flow Body instruments are only available with Viton elastomers. Valve Seat applies only to controllers.

Actual Gas	Chemical Symbol	K-factor Relative N2	Cp (Cal/g)	Density (g/l) @ 0°C	Elastomer* O-ring Valve Seat	Nylon Compatible
Dichloromethylsilane	(CH ₃) ₂ SiCl ₂	.25	.1882	5.758	KR	
Dichlorosilane	SiH ₂ CL ₂	.40	.150	4.506	KR	
Dichlorotetrafluoroethane (Freon-114)	C ₂ CL ₂ F ₄	.22	.1604	7.626	KR	
1,1-Difluoroethylene (Freon-1132A)	C ₂ H ₂ F ₂	.43	.224	2.857	KR	
Dimethylamine	(CH ₃) ₂ NH	.37	.366	2.011	KR	
Dimethyl Ether 2,2-Dimethylpropane	(CH ₃) ₂ O	.39	.3414	2.055	KR	
Ethane	C ₃ H ₁₂	.22	.3914	3.219	KR	
	C ₂ H ₆	.50	.4097	1.342		NO
Ethanol	C ₂ H ₆ O	.39	.3395	2.055	KR	
EthylAcetylene	C ₄ H ₆	.32	.3513	2.413	KR	
Ethyl Chloride	C ₂ H ₅ CL	.39	.244	2.879	KR	
Ethylene	C ₂ H ₄	.60	~.358	1.251		
Ethylene Oxide	C ₂ H ₄ O	.52	.268	1.965	KR	
Fluorine	F ₂	.980	.1873	1.695	KR	
Fluoroform (Freon-23)	CHF ₃	.50	.176	3.127	KR	NO
Freon-11	CCL ₃ F	.33	.1357	6.129	KR	NO
Freon-12	CCL ₂ F ₂	.35	.1432	5.395	KR	NO
Freon-13	CCLF ₃	.38	.153	4.660	KR	NO
Freon-13 B1	CFrF ₃	.37	.1113	6.644	KR	NO
Freon-14	C F ₄	.42	.1654	3.926		NO
Freon-21	CHCL ₂ F	.42	.140	4.952	KR	NO
Freon-22	CHCLF ₂	.46	.1544	3.858	KR	NO
Freon-113	CCl₂FCCLF₂	.20	.161	8.360	KR	NO
Freon-114	C ₂ CL ₂ F ₄	.22	.160	7.626	KR	NO
Freon-115	C ₂ CLF ₅	.24	.164	6.892	KR	NO
Freon-C318	C ₄ F ₆	.17	.185	8.397	KR	NO
Germane	GeH ₄	.57	.1404	3.418		
Germanium Tetrachloride	GeCL ₄	.27	.1071	9.565	KR	
Helium	He	1.454	1.241	.1786		
Hexafluoroethane (Freon-116)	C ₂ F ₆	.24	.1834	6.157	KR	NO
Hexane	C ₆ H ₁₄	.18	.3968	3.845	KR	
Hydrogen	H ₂	1.01	3.419	.0899		
Hydrogen Bromide	HBr	1.000	.0861	3.610		KR
Hydrogen Chloride	HCL	1.000	.1912	1.627	K	KR
Hydrogen Cyanide	HCN	.76	.3171	1.206		KR
Hydrogen Fluoride	HF	1.000	.3479	.893	KR	KR
Hydrogen Iodide	HI	1.000	.0545	5.707		KR
Hydrogen Selenide	H ₂ Se	.79	.1025	3.613		KR
Hydrogen Sulfide	H ₂ S	.80	.2397	1.520	KR	KR
Iodine Pentafluoride	IF ₅	.25	.1108	9.90		KR
Isobutane	CH(CH ₃) ₃	.27	.3872	2.593		KR
Isobutylene	C ₄ H ₆	.29	.3701	2.503		KR
Krypton	Kr	1.453	.0593	3.739		
Methane	C H ₄	.72	.5328	.715		
Methanol	CH ₃ OH	.58	.3274	1.429		
Methyl Acetylene	C ₃ H ₄	.43	.3547	1.787		KR
Methyl Bromide	CH ₃ Br	.58	.1106	4.236		
Methyl Chloride	CH ₃ CL	.63	.1926	2.253		KR
Methyl Fluoride	CH ₃ F	.68	.3221	1.518		KR

* If no O-ring material is specified then O-ring to be used is Viton. . Nylon Flow Body instruments are only available with Viton elastomers.

Actual Gas

	Chemical Symbol	K-factor Relative N₂	Cp (Cal/g)	Density (g/l) @ 0°C	Elastomer*O- ring Valve Seat	Nylon Compatible
Methyl Mercaptan	CH ₃ SH	.52	.2459	2.146	KR	
Methyl Trichlorosilane	(CH ₃) SiCl ₃	.25	.164	6.669	KR	
Molybdenum Hexafluoride	MoF ₆	.21	.1373	9.366	KR	
Monoethylamine	C ₂ H ₅ NH ₂	.35	.387	2.011	KR	
Monomethylamine	CH ₃ NH ₂	.51	.4343	1.386	KR	
Neon	NE	1.46	.245	.900		
Nitric Oxide	NO	.990	.2328	1.339		NO
Nitrogen	N ₂	1.000	.2485	1.25		
Nitrogen Dioxide	NO ₂	.74	.1933	2.052	KR	KR
Nitrogen Trifluoride	NF ₃	.48	.1797	3.168		KR
Nitrosyl Chloride	NOCl	.61	.1632	2.920		KR
Nitrous Oxide	N ₂ O	.71	.2088	1.964		
Octafluorocyclobutane (Freon-C318)	C ₄ F ₆	.17	.185	8.397		KR
Oxygen	O ₂	1.000	.2193	1.427		
Oxygen Difluoride	OF ₂	.63	.1917	2.406		
Ozone	O ₃	.446	.3	2.144		NO
Pentaborane	B ₅ H ₉	.26	.38	2.816		KR
Pentane	C ₅ H ₁₂	.21	.398	3.219		KR
Perchloryl Fluoride	ClO ₃ F	.39	.1514	4.571		KR
Perfluoropropane	C ₃ F ₈	.174	.197	8.388		KR
Phosgene	COCl ₂	.44	.1394	4.418		KR
Phosphine	Ph ₃	.76	.2374	1.517		KR
Phosphorous Oxychloride	POCl ₃	.36	.1324	6.843		KR
Phosphorous Pentafluoride	Ph ₅	.30	.1610	5.620		KR
Phosphorous Trichloride	PCL ₅	.30	.1250	6.127		KR
Propane	C ₃ H ₈	.36	.3885	1.967		
Propylene	C ₃ H ₆	.41	.3541	1.877		
Silane	SiH ₄	.60	.3189	1.433		KR
Silicon Tetrachloride	SiCL ₄	.28	.1270	7.580		KR
Silicon Tetrafluoride	SiF ₄	.35	.1691	4.643		KR
Sulfur Dioxide	SO ₂	.69	.1488	2.858		KR
Sulfur Hexafluoride	SF ₆	.26	.1592	6.516		KR
Sulfuryl Fluoride	SO ₂ F ₂	.39	.1543	4.562		KR
Teos		.090			KR	KR
Tetrafluorahydrazine	N ₂ F ₄	.32	.182	4.64		KR
Trichlorofluormethane (Freon-11)	CCL ₃ F	.33	.1357	6.129		KR
Trichlorisilane	SiHCL ₃	.33	.1380	6.043		KR
1,1,2-Trichloro-1,2,2 Trifluorethane (Freon-113)	CCL ₂ FCCLF ₂	.20	.161	8.360		KR
Trisobutyl Aluminum	(C ₄ H ₉)AL	.061	.508	8.848		KR
Titanium Tetrachloride	TiCL ₄	.27	.120	8.465		KR
Trichloro Ethylene	C ₂ HCL ₃	.32	.163	5.95		KR
Trimethylamine	(CH ₃) ₃ N	.28	.3710	2.639		KR
Tungsten Hexasfluoride	WF ₆	.25	.0810	13.28	KR	Teflon
Uranium Hexafluoride	UF ₆	.20	.0888	15.70		KR
Vinyl Bromide	CH ₂ CHBr	.46	.1241	4.772		KR
Vinyl Chloride	CH ₂ CHCL	.48	.2054	2.788		KR
Xenon	Xe	1.44	.0378	5.858		

* If no O-ring material is specified then O-ring to be used is Viton. Nylon Flow Body instruments are only available with Viton elastomers.

Appendix B Product Specifications

Operating Specifications

Gases	Dependent on wetted materials. Check compatibility and specify when ordering.	
Mass Flow Rates	Nylon Flow Body: 0 to 10 sccm to 0 to 50 slpm Stainless Steel Flow Body: 0 to 10 sccm to 0 to 100 slpm Note: flow ranges specified are for an equivalent flow of nitrogen at 760 mm Hg and 21 °C (70°F); other ranges in other units are available (e.g. scfh or nm ³ /h)	
Gas Pressure	Nylon Flow Body: 150 psig (10 barg) maximum ; 20 psig optimum Stainless Steel Flow Body: 500 psig (34 barg) maximum. 1000 psig (68.9 barg) maximum available for low flow bodies only upon request, please consult factory; 30 psig (2 barg) optimum	
Gas & Ambient Temperature	32° to 122°F (0 to 50°C); higher available on special order	
Leak Integrity	Nylon Flow Body: 1 X 10 ⁻⁴ atm cc/sec of helium maximum Stainless Steel Flow Body: 5 X 10 ⁻⁹ atm cc/sec of helium maximum	
Pressure Drop (for meters) 810M	Up to 10 slpm	0.10 psi (6.9 mbar) max.
	Up to 20 slpm	0.36 psi (24.5 mbar) max.
	Up to 30 slpm	0.67 psi (46.1 mbar) max.
	Up to 50 slpm	1.25 psi (86.3 mbar) max.
Differential Pressure Requirements (for controllers)		
	810C (nylon)	5 to 50 psi (1.0 to 3.4 bar) differential standard; 30 psi (2.1 bar) differential optimum
	810S (low)	8 to 100 psi (1.0 to 3.4 bar) differential standard; 30 psi (2.1 bar) differential optimum; lower (10 Torr minimum) or higher are available by special order
	810S (med)	15 to 50 psi (1.0 to 2.8 bar) differential standard; 30 psi (2.1 bar) differential optimum; lower (5 psi minimum) or higher available by special order
Power Requirements	810M.....	+24VDC @ 100 mA. Ripple content should not exceed 100 mV peak-to-peak. A regulated power supply is not required.
	810C, 810S.....	+24 VDC @ 350 mA. Ripple current should not exceed 50 mV peak to peak. A regulated power supply is required
Control Range	810C, 810S	2 to 100% of full scale; valve shuts when flow drops below 0.5 - 3% of range (override is available)
Output Signal	Linear 0-5 VDC, 2000 Ohms minimum load resistance Linear 4-20 mA, 1000 Ohms maximum loop resistance	
Command Signal	0-5 VDC, into 2000 ohms minimum input impedance 4-20 mA, into 250 ohms maximum input impedance	

Performance Specifications

Accuracy	$\pm 1.5\%$ of full scale including linearity over 15 to 25°C and ± 30 psig from calibration pressure. If the instrument is mounted with a vertical flow path, an accuracy de-rating may apply.
Repeatability	$\pm 0.25\%$ of full scale
Temperature Coefficient	0.08% of full scale per °C, or better
Pressure Coefficient	0.01% of full scale per psi (0.15% of full scale per bar), or better
Response Time	800 ms time constant; 6 seconds (typical) to within $\pm 2\%$ of final value over 25 to 100% of full scale

Physical Specifications

Wetted Materials	810M or C (nylon) 10% glass-filled Nylon® 6/6; 316 stainless steel, 430F stainless steel, nickel plating, Viton® O-rings
	810S 316 stainless steel, 430F stainless steel, Viton® O-rings and valve seat standard; Neoprene®, 4079 Kal-Rez® (or equivalent) and other elastomers available on special order; PFA Teflon® valve seat available
Control Valve Type	810C, 810S Electromagnetic

Transducer Mounting Dimensions

All dimensions are inches, millimeters are in parentheses. Certified drawings are available on request.

Nylon Flow Body

Mount the Mass-Trak to a chassis with two #6, type “B” self-tapping screws.

CAUTION: These screws should extend into the flow body no further than .15” (4mm). If screws extend further than .15” (4mm), the flow body may be damaged. See Figure 2-1

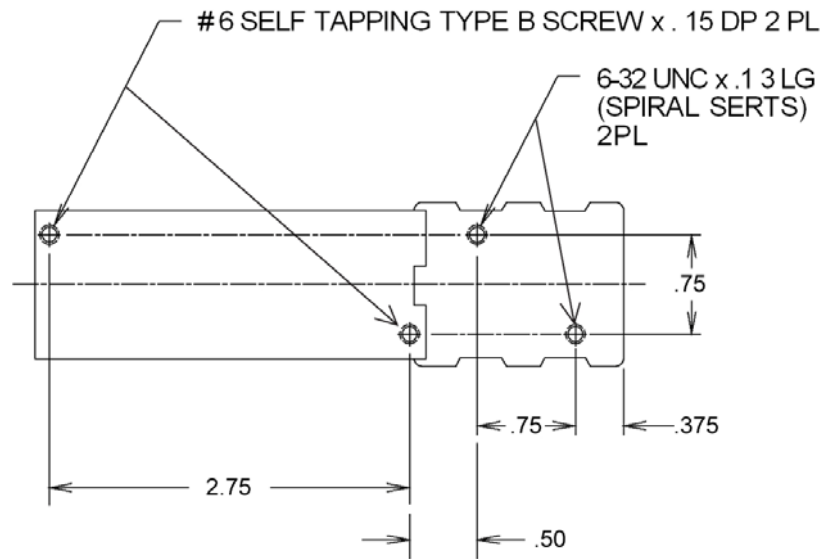
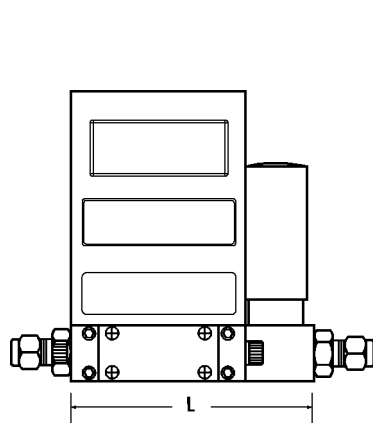

Figure B-1. Mounting the Mass-Trak (Model 810 C)

Stainless Steel Low Flow Body

Flow Range, 0–10 sccm to 0–15 slpm			
Process Tubing		.25 (6.4)	
.562-18 Thread (on Flow Body)			
Fitting Type	Compression .125 or .25	VCO (male) .25	VCR (male) .25
Dim. L	6.02 (122.9 or 127.0)	5.78 (116.8)	6.08 (124.5)
Metric fittings are available, consult factory			



Model 810-S Side View

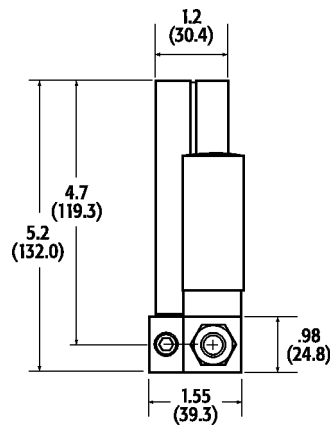

Model 810-S Outlet View

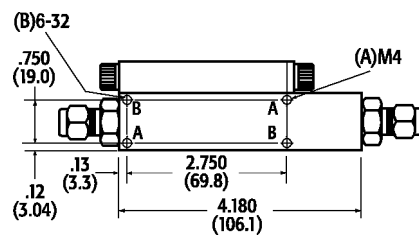

Model 810-S Bottom View

Stainless Steel Medium Flow Body

Flow Range, 0–10 sccm to 0–15 slpm			
Process Tubing		.25 (6.4)	
.562-18 Thread (on Flow Body)			
Fitting Type	Compression .125 or .25	VCO (male) .25	VCR (male) .25
Dim. L	7.17 (122.9 or 127.0)	6.67 (116.8)	6.97 (124.5)
Metric fittings are available, consult factory			

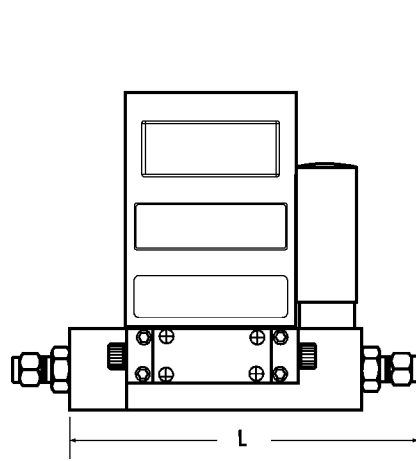

Model 810-S Side View

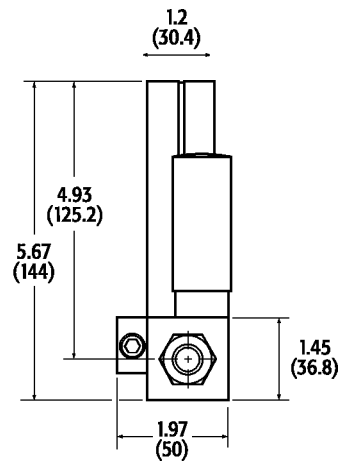

Model 810-S Outlet View

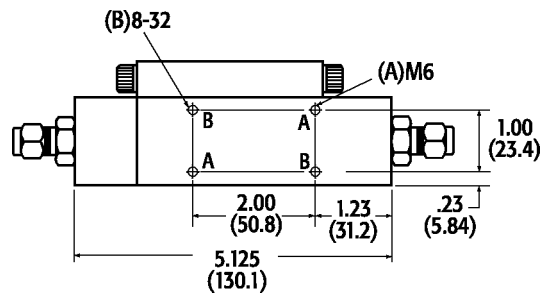

Model 810-S Bottom View

Appendix C Pin Connections

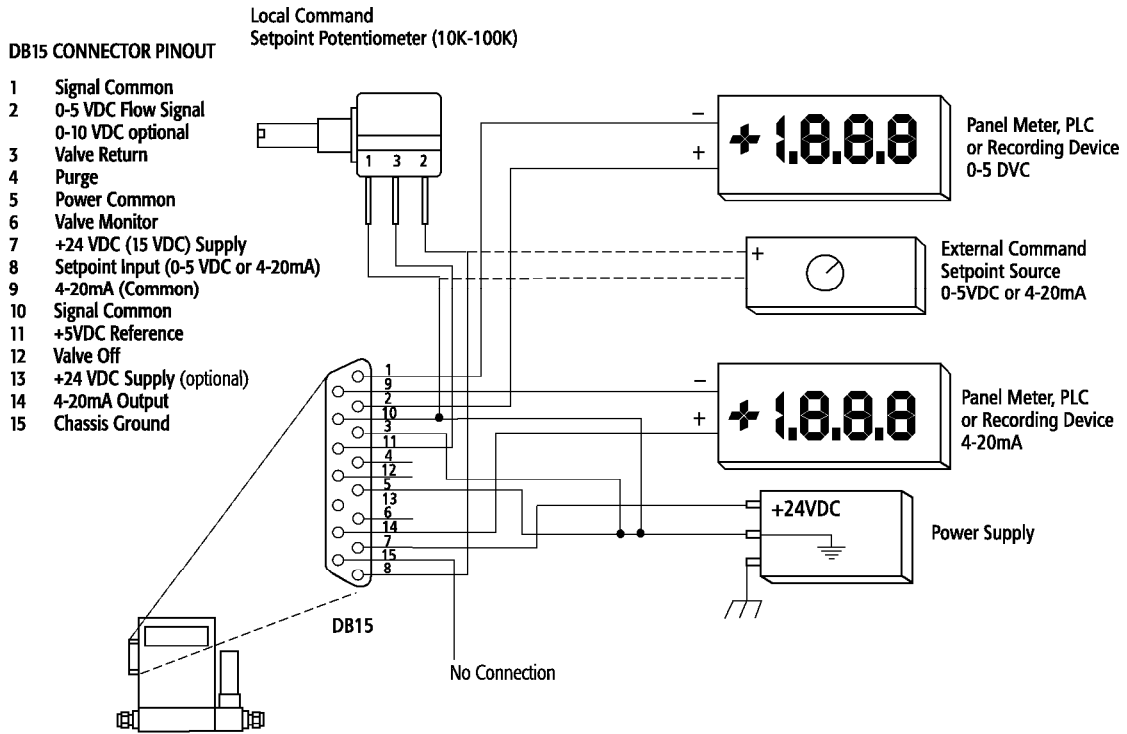

Note: Pins 1, 3, 5, 9 and 10 are all tied together internally. However it is highly recommended that at least one "signal common", one "power common" and the "valve return" pins be connected to the power supply common via separate wires, so that no ground loops are introduced, (especially on cables longer than ten feet)

Appendix D Purge and Valve Off Connections

DB15 CONNECTOR PINOUT

- 1 Signal Common
- 2 0-5 VDC Flow Signal
0-10 VDC optional
- 3 Valve Return
- 4 Purge
- 5 Power Common
- 6 Valve Monitor
- 7 +24VDC (15VDC) Supply
- 8 Setpoint Input (
- 9 4-20mA (Common)
- 10 Signal Common
- 11 +5VDC Reference
- 12 Valve Off
- 13 +24 VDC (15 VDC) Supply
- 14 4-20mA Output
- 15 Chassis Ground

