



InnovaMass^s 240S/241S Series

Vortex Volumetric and Mass Flow Meters

Instruction Manual

Models: 240S Inline, 241S Insertion, and 240S-R Reduced Bore

Version: W, December 2025

PN: IM-240

Global Support

SIERRA INSTRUMENTS, INC.

USA HEADQUARTERS

20 Ryan Ranch Road, Suite 109

Monterey, CA 93940 USA

Phone +1(831) 373-0200

www.sierrainstruments.com

SIERRA INSTRUMENTS, INC.

ASIA HEADQUARTERS

Second Floor Building 5

Senpu Industrial park

25 Hangdu Road Hangtou Town

Pu Dong New District

Shanghai, P.R. China

Post Code 201316

Phone: + 8621 5879 8521

Customer Notice for Oxygen Service

Unless you have specifically ordered Sierra's optional O₂ cleaning, this flow meter may not be fit for oxygen service. Some models can only be properly cleaned during the manufacturing process. Sierra Instruments, Inc., is not liable for any damage or personal injury, whatsoever, resulting from the use of Sierra Instruments standard mass flow meters for oxygen gas.

Specific Conditions of Use (ATEX/IECEX)

Contact Manufacturer regarding Flame path information.

Clean with a damp cloth to avoid any build-up of electrostatic charge.

The model 240S, 241s, and 240-R Multivariable Mass Vortex Flowmeters standard temperature option (ST) process temperature range is -40°C to 260°C. The high temperature option (HT) process temperature range is -40°C up to +400°C.

InnovaMass Multivariable Mass Vortex Flowmeters		
Tmax (Process)	Temperature Class Value (Gas)	
	ST Version	HT Version
80°C	T6	85°C
95°C	T5	100°C
130°C	T4	135°C
195°C	T3	200°C
260°C	T2	300°C
400°C	N / A	405°C



Notice to Users

Warning based on Electric Appliances Safety Control Act of Korea. This product should be handled as electromagnetic radiation emitting equipment and is intended for use by industrial dealers and end-users. It is not for residential use.

NIST Standard Reference Database 23, NIST Reference Fluid Thermodynamic and Transport Properties: REFPROP Version 9.x. Standard Reference Databases are copyrighted by the U.S. Secretary of Commerce on behalf of the United States of America. All rights reserved. No part of the database may be reproduced, stored in a retrieval system or transmitted, in any form or by any means, electronic, mechanical, photocopying, recording or otherwise without prior permission.

©Copyright Sierra Instruments 2025

No part of this publication may be copied or distributed, transmitted, transcribed, stored in a retrieval system, or translated into any human or computer language, in any form or by any means, electronic, mechanical, manual, or otherwise, or disclosed to third parties without the express written permission of Sierra Instruments. The information contained in this manual is subject to change without notice.

Trademarks

InnovaFlo® and InnovaMass® is a trademark of Sierra Instruments, Inc. Other product and company names listed in this manual are trademarks or trade names of their respective manufacturers.

Table of Contents

Global Support	1
Chapter 1 Introduction	11
InnovaMass Multivariable Mass Flow Meters	11
Multivariable Mass Flow Meters	11
Volumetric Flow Meters.....	11
Using This Manual.....	11
Note and Safety Information.....	11
Receipt of System Components	12
Technical Assistance.....	12
How the InnovaMass® Vortex Mass Flow Meter Operates.....	13
Velocity Measurement.....	13
Vortex Shedding Frequency.....	14
Vortex Frequency Sensing.....	14
Flow Velocity Range	15
Pressure Drop.....	16
Minimum Back Pressure	17
Temperature Measurement.....	17
Pressure Measurement.....	17
Flow Meter Configurations	17
Multivariable Options.....	18
Line Size / Process Connections / Materials	18
Flow Meter Electronics	18
Chapter 2 Installation	20
Installation Overview.....	20
Flow Meter Installation Requirements.....	20
Unobstructed Flow Requirements	21
Recommended Meter Locations.....	22
Series 240S In-Line Flow Meter Installation.....	23
Flange Bolt Specifications	23
Wafer-Style Flow Meter Installation.....	23
Flange-Style Flow Meter Installation.....	25
Series 241S Insertion Flow Meter Installation.....	26

Mounting Position.....	26
Isolation Valve Selection.....	26
Cold Tap Guidelines.....	27
Hot Tap Guidelines.....	28
Flow Meter Insertion.....	30
Use the Correct Insertion Formula.....	30
Installing Flow Meters with a Compression Connection*.....	31
Installing Flow Meters with a Packing Gland Connection*.....	33
Installation of Meters with Packing Gland Connection (No Insertion Tool) *.....	36
Adjusting Meter Orientation.....	38
Display/Keypad Adjustment (All Meters).....	38
Enclosure Adjustment (Series 240S Only).....	39
Loop Power Flow Meter Wiring Connections.....	40
Input Power Connections.....	40
4-20 mA Output Connections.....	41
Pulse Output Connections.....	42
Frequency Output Connections.....	43
Optional Backlight Connection.....	44
Remote Electronics Wiring.....	44
High Power Meter Wiring Connections.....	47
Input Power Connections.....	48
4-20 mA Output Connections.....	50
Pulse Output Connections.....	53
Frequency Output Connections.....	55
Alarm Output Connections.....	57
Remote Electronics Wiring.....	60
Optional Input Electronics Wiring.....	62
Optional Energy EMS RTD Input Wiring.....	62
Optional External 4-20 mA Input Wiring.....	63
Optional External 4-20 mA Input and RTD Wiring.....	64
Optional Energy EMS External 4-20 mA Input and RTD Wiring.....	65
Optional External Contact Closure Input Wiring.....	65
Chapter 3 Operating Instructions.....	66

Flow Meter Display/Keypad.....	66
Display Contrast Adjustment.....	67
Start-Up.....	67
Run Mode Screens.....	68
Using the Setup Menus.....	69
Programming the Flow Meter.....	70
Output Menu.....	71
Display Menu.....	74
Alarms Menu.....	75
Totalizer #1 Menu.....	77
Totalizer #2 Menu.....	78
Energy Menu (For EMS Energy Meters Only).....	79
Fluid Menu.....	80
Units Menu.....	82
Time & Date Menu.....	83
Diagnostics Menu.....	84
Calibration Menu.....	86
Password Menu.....	87
Chapter 4 Serial Communications.....	88
HART Communications.....	88
Wiring.....	88
HART Commands with the DD Menu.....	90
HART Commands with Generic DD Menu.....	97
Modbus Communications.....	98
Applicable Flow Meter Models.....	98
Overview.....	98
Reference Documents.....	98
Wiring.....	98
Menu Items.....	99
BACnet MS/TP Communications.....	108
Description.....	108
Wiring.....	108
Baud Rates on the MS/TP Bus.....	108

Supported BACnet Objects	109
ANNEX – BACnet Protocol Implementation Conformance Statement.....	115
Acronyms and Definitions	121
POE Communications.....	122
Direct Connection Options.....	122
Network Configuration.....	123
Meter WEB Pages.....	129
Internet Connection to the Meter – Security Issues.....	141
Modbus/TCP Interface.....	144
BACnet/TCP Interface.....	145
Data Logging	146
Updating the Firmware.....	150
Chapter 5 Troubleshooting and Repair.....	151
Hidden Diagnostics Menus	151
Level One Hidden Diagnostics Values.....	153
Level Two Hidden Diagnostics Values.....	154
Analog Output Calibration.....	156
Display Contrast Adjustment.....	156
Troubleshooting the Flow Meter	157
Electronics Assembly Replacement (All Meters)	163
Returning Equipment to the Factory.....	164
Factory Calibration—All Models.....	164
Instructions for Returning Your Instrument for Service	164
Please follow these easy steps to return your instrument for factory service:	164

Appendix A Product Specifications

Appendix B Approvals

Appendix C Flow Meter Calculations

Appendix D Glossary

Appendix E Warranty Policy

Figures

Figure 1 - In-Line Vortex Multi-Parameter Mass Flow Meter.....	13
Figure 2 - Measurement Principle of Vortex Flow Meters.....	14
Figure 3 - Reynolds Number Range for the InnovaMass.....	16
Figure 4 - Recommended Pipe Length Requirements for Installation, Series 240S/241S.....	21
Figure 5 - Flange Bolt Torquing Sequence.....	23
Figure 6 - Wafer-Style Flow Meter Installation.....	24
Figure 7 - Flange-Style Flow Meter Installation.....	25
Figure 8 - Hot Tap Sequence.....	29
Figure 9 - Insertion Calculation (Compression Type).....	31
Figure 10 - Flow Meter with Compression Type Fitting.....	32
Figure 11 - Insertion Calculation (Meters with Insertion Tool).....	33
Figure 12 - Flow Meter with Permanent Insertion Tool.....	34
Figure 13 - Flow Meter with Removable Insertion Tool.....	35
Figure 14 - Insertion Calculation (Meters without Insertion Tool).....	36
Figure 15 - Display/Keypad Viewing Adjustment.....	38
Figure 16 - Enclosure Viewing Adjustment.....	39
Figure 17 - Loop Power Wiring Terminals.....	40
Figure 18 - DC Power Connections.....	41
Figure 19 - Load Resistance Versus Input Voltage.....	41
Figure 20 - Loop Power 4-20 mA Wiring Diagram.....	42
Figure 21 - Isolated Pulse Output Using External Power Supply.....	42
Figure 22 - Non-Isolated Pulse Output Using External Power Supply.....	43
Figure 23 - Isolated Frequency Output Using External Power Supply.....	43
Figure 24 - Non-Isolated Frequency Output Using External Power Supply.....	44
Figure 25 - Backlight Using External Power Supply.....	44
Figure 26 - Loop Power Volumetric Flowmeter Junction Box Sensor Connections.....	45
Figure 27 - Loop Power Volumetric Flowmeter Junction Box Sensor Connections Supplied Prior to Jan. 1, 2014.....	46
Figure 28 - Loop Power Mass Flowmeter Junction Box Sensor Connections.....	46
Figure 29 - AC Wiring Terminals.....	47
Figure 30 - DC Wiring Terminals.....	47
Figure 31 - POE Wiring Terminals.....	48
Figure 32 - AC Power Connections.....	48
Figure 33 - DC Power Connections.....	49
Figure 34 - DC POE Power Connections.....	49
Figure 35 - Front of the LAN Connector.....	50
Figure 36 - Load Resistance Versus Input Voltage.....	50
Figure 37 - Isolated 4-20mA Output Using External Power Supply.....	51
Figure 38 - Non-Isolated 4-20 mA Output Using Meter Input Power Supply.....	51

Figure 39 - Isolated 4-20 mA Output Using External Power Supply..... 52

Figure 40 - Isolated 4-20 mA Output Using Meter Provided Power Supply..... 52

Figure 41 - Isolated Pulse Output Using External Power Supply 53

Figure 42 - Non-Isolated Pulse Output Using Input Power Supply 54

Figure 43 - Isolated Pulse Output Using External Power Supply 54

Figure 44 - Isolated Pulse Output Using Meter Provided Power Supply 55

Figure 45 - Isolated Frequency Output Using External Power Supply..... 56

Figure 46 - Non-Isolated Frequency Output Using Input Power Supply 56

Figure 47 - Isolated Frequency Output Using External Power Supply..... 57

Figure 48 - Non-Isolated Frequency Output Using Meter Provided Power Supply 57

Figure 49 - Isolated Alarm Output Using External Power Supply..... 58

Figure 50 - Non-Isolated Alarm Output Using Internal Power Supply 59

Figure 51 - Isolated Alarm Output Using External Power Supply..... 59

Figure 52 - Non-Isolated Alarm Output Using Meter Provided Power Supply..... 60

Figure 53 - High Power Flowmeter Junction Box Sensor Connections..... 61

Figure 54 - Optional Terminal Blocks..... 62

Figure 55 - Loop Power EMSRTD..... 62

Figure 56 - High Power EMSRTD..... 62

Figure 57 - External 4-20 mA Input Wiring - External Power Supply 63

Figure 58 - External 4-20 mA Input Wiring - DC Powered Meter 63

Figure 59 - External 4-20 mA Input Wiring - AC Powered Meter..... 64

Figure 60 - External 4-20 mA Input and RTD Wiring - Loop Power..... 64

Figure 61 - External 4-20 mA Input and RTD Wiring - High Power 64

Figure 62 - Energy EMS External 4-20 mA Input and RTD Wiring - High Power 65

Figure 63 - Optional External Contact Closure Input Wiring..... 65

Figure 64 - Flow Meter Display/Keypad..... 66

Figure 65 - Loop Powered Meter Wiring (HART)..... 88

Figure 66 - DC Powered Meter Wiring (HART)..... 89

Figure 67 - AC Powered Meter Wiring (HART)..... 89

Figure 68 - RS-485 Wiring (MODBUS)..... 98

Figure 69 - RS-485 Wiring (BACnet)..... 108

Figure 70 - IPSetup Displaying the Current IP Address..... 128

Figure 71 - IPSetup Displaying the Unique Identifier Code VRTX (NetBIOS Name)..... 128

Figure 72 - Main/Home Page..... 130

Figure 73 - Flow Menu 130

Figure 74 - Meter Menu..... 131

Figure 75 - Fluid Menu..... 131

Figure 76 - Diagnostic Menu..... 132

Figure 77 - Configure Menu..... 132

Figure 78 - Configure Password Protection 133

Figure 79 - Data log Menu 133

Figure 80 - Startup Log Menu 134

Figure 81 - Output Tab..... 135

Figure 82 - External Input Tab..... 135

Figure 83 - Display Tab.....	136
Figure 84 - Alarms Tab.....	136
Figure 85 - Totalizer Tab.....	137
Figure 86 - Units Tab.....	137
Figure 87 - Fluid Tab.....	137
Figure 88 - Diagnostics Tab.....	138
Figure 89 - Calibration Tab.....	138
Figure 90 - SD Log Config. Tab.....	139
Figure 91 - HART Tab.....	139
Figure 92 - System Tab.....	140
Figure 93 - Diagnostic Level 1 Troubleshooting Values 1 Tab.....	140
Figure 94 - Diagnostics Level 1 Troubleshooting Values 2 Tab.....	140
Figure 95 - Diagnostics Level 2 4-20 mA Configuration Tab.....	141
Figure 96 - Diagnostic Level 2 Factory Configuration Tab.....	141
Figure 97 - EXE Folder.....	145
Figure 98 - Calibration Tab with BACnet Selected.....	145
Figure 99 - Data Log Menu.....	146
Figure 100 - EXCEL Example.....	148
Figure 101 - SD Log Configuration Tab.....	149
Figure 102 - AutoUpdate.....	150
Figure 103 - Electronic Stack Sensor Connections (Local Meters).....	160
Figure 104 - Remote Feedthrough Board Sensor Connections (Remote Meters).....	160
Figure 105 - Vortex Sensor Connector.....	160
Figure 106 - Temperature Sensor Connector.....	161
Figure 107 - Pressure Sensor Connector.....	162

Warnings and Cautions



Warning!

Consult the flow meter nameplate for specific flow meter approvals before any hazardous location installation.

Hot tapping must be performed by a trained professional. U.S. regulations often require a hot tap permit. The manufacturer of the hot tap equipment and/or the contractor performing the hot tap is responsible for providing proof of such a permit.

All flow meter connections, isolation valves and fittings for cold/hot tapping must have the same or higher pressure rating as the main pipeline.

For Series 241S insertion flow meter installations, an insertion tool must be used for any installation where a flow meter is inserted under pressure greater than 50 psig.

To avoid serious injury, DO NOT loosen a compression fitting under pressure.

To avoid potential electric shock, follow National Electric Code or your local code when wiring this unit to a power source. Failure to do so could result in injury or death. All AC power connections must be in accordance with published CE directives. All wiring procedures must be performed with the power Off.

Before attempting any flow meter repair, verify that the line is not pressurized. Always remove main power before disassembling any part of the mass flow meter.



Caution!

Calibration must be performed by qualified personnel. Sierra Instruments Inc., strongly recommends that you return your flow meter to the factory for calibration.

In order to achieve accurate and repeatable performance, the flow meter must be installed with the specified minimum length of straight pipe upstream and downstream of the flow meter's sensor head.

When using toxic or corrosive gases, purge the line with inert gas for a minimum of four hours at full gas flow before installing the flow meter.

For Series 241S insertion flow meter installations, the sensor alignment pointer must point downstream in the direction of flow.

The AC wire insulation temperature rating must meet or exceed 85°C (185°F).

Chapter 1 Introduction

InnovaMass Multivariable Mass Flow Meters

Sierra Instruments InnovaMass240S Inline and InnovaMass241S Insertion vortex flow meters provide a reliable solution for process flow measurement. From a single entry point in the pipeline, the InnovaMass 240S and 241S offer precise measurements of mass or volumetric flow rates.

Multivariable Mass Flow Meters

Mass flow meters utilize three primary sensing elements: a vortex shedding velocity sensor, an RTD temperature sensor, and a solid state pressure sensor to measure the mass flow rate of gases, liquids, and steam. Meters are available as loop powered devices or with up to three 4-20 mA analog output signals for monitoring your choice of the five process variables (mass flow, volumetric flow, temperature, pressure and fluid density). The Energy Monitoring option permits real-time calculation of energy consumption for a facility or process.

Volumetric Flow Meters

The primary sensing element of a volumetric flow meter is a vortex shedding velocity sensor. The analog 4-20 mA output signal offers your choice of volumetric or mass flow rate. Mass flow rate is based on a constant value for fluid density stored in the instrument's memory.

Both the mass and volumetric flow meters can be ordered with a local keypad/display which provides instantaneous flow rate, total, and process parameters in engineering units. A pulse output signal for remote totalization and MODBUS, HART, BACnet, and IP version of MODBUS/BACnet communications are also available. InnovaMass digital electronics allows for easy reconfiguration for most gases, liquids, and steam. The Sierra InnovaMass 240S and 241S vortex meters' simple installation combines with an easy-to-use interface that provides quick set up, long term reliability and accurate mass flow measurement over a wide range of flows, pressures, and temperatures.

Using This Manual

This manual provides information needed to install and operate both the Series 240S In-Line and Series 241S Insertion InnovaMass vortex Flow Meters.

- Chapter 1 includes the introduction and product description
- Chapter 2 provides information needed for installation
- Chapter 3 describes system operation and programming
- Chapter 4 information on HART, MODBUS, and BACnet protocols
- Chapter 5 covers troubleshooting and repair

Appendix A - Product Specifications, Appendix B – Approvals, Appendix C – Flow Meter Calculations, Appendix D – Glossary of Terms, Appendix E – Warranty Policy

Note and Safety Information

We use note, caution, and warning statements throughout this book to draw your attention to important information.



Warning!

This statement appears with information that is important to protect people and equipment from damage. Pay very close attention to all warnings that apply to your application.



Caution!

This statement appears with information that is important for protecting your equipment and performance. Read and follow all cautions that apply to your application.



Note

This statement appears with a short message to alert you to an important detail.

Receipt of System Components

When receiving a Sierra Instruments mass flow meter, carefully check the outside packing carton for damage incurred in shipment. If the carton is damaged, notify the local carrier and submit a report to the factory or distributor. Remove the packing slip and check that all ordered components are present. Make sure any spare parts or accessories are not discarded with the packing material. Do not return any equipment to the factory without first contacting Sierra Instruments Customer Service.

Technical Assistance

If you encounter a problem with your flow meter, review the configuration information for each step of the installation, operation and set up procedures. Verify that your settings and adjustments are consistent with factory recommendations. Refer to Chapter 5, Troubleshooting, for specific information and recommendations.

If the problem persists after following the troubleshooting procedures outlined in Chapter 5, contact Sierra Instruments, Technical Support Via Email at service@sierrainstruments.com or by phone at (831) 373-0200 between 8:00 a.m. and 5:00 p.m. PST. In the Asia-Pacific region, contact Sierra Instruments Asia at +8621 5879 8521. When calling Technical Support, have the following information on hand:

- the serial number and Sierra order number (all marked on the meter nameplate)
- the problem you are encountering and any corrective action taken
- application information (fluid, pressure, temperature, and piping configuration)

How the InnovaMass® Vortex Mass Flow Meter Operates

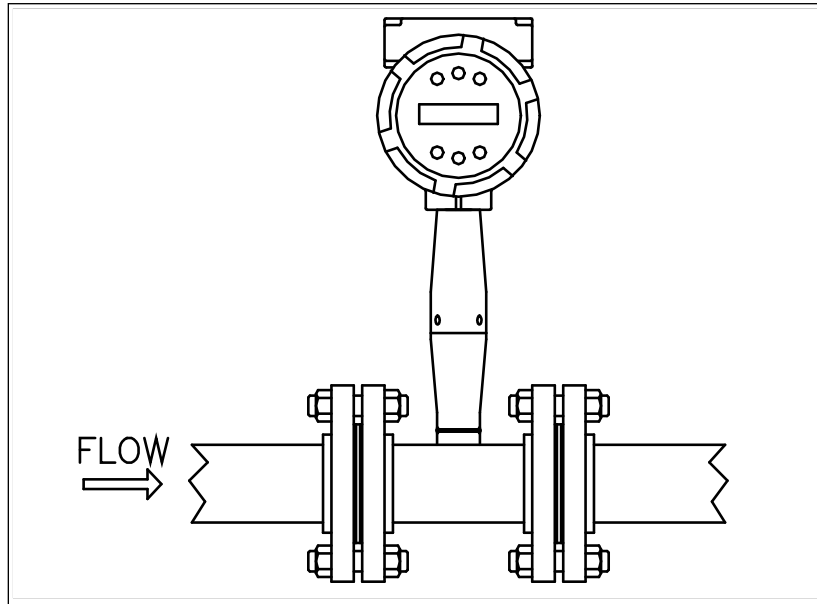

Figure 1 - In-Line Vortex Multi-Parameter Mass Flow Meter

Sierra's InnovaMass 240S/241S Series Multivariable Vortex Mass Flow Meters use a unique sensor head to monitor mass flow rate by directly measuring three variables – fluid velocity, temperature, and pressure. The built-in flow computer calculates the mass flow rate and volumetric flow rate based on these three direct measurements. The velocity, temperature and pressure sensing head is built into the vortex meter's flow body. To measure fluid velocity, the flow meter incorporates a bluff body (shedder bar) in the flow stream and measures the frequency of vortices created by the shedder bar. Temperature is measured using a platinum resistance temperature detector (PRTD). Pressure measurement is achieved using a solid-state pressure transducer. All three elements are combined into an integrated sensor head assembly located downstream of the shedder bar within the flow body.

Velocity Measurement

The InnovaMass® vortex velocity sensor is a patented mechanical design that minimizes the effects of pipeline vibration and pump noise, both of which are common error sources in flow measurement with vortex flow meters. The velocity measurement is based on the well-known Von Karman vortex shedding phenomenon. Vortices are shed from a shedder bar, and the vortex velocity sensor located downstream of the shedder bar senses the passage of these vortices. This method of velocity measurement has many advantages including inherent linearity, high turndown, reliability, and simplicity.

Vortex Shedding Frequency

Von Karman vortices form downstream of a shedder bar into two distinct wakes. The vortices of one wake rotate clockwise while those of the other wake rotate counterclockwise. Vortices generate one at a time, alternating from the left side to the right side of the shedder bar. Vortices interact with their surrounding space by over-powering every other nearby swirl on the verge of development. Close to the shedder bar, the distance (or wave length) between vortices is always constant and measurable. Therefore, the volume encompassed by each vortex remains constant, as shown below. By sensing the number of vortices passing by the velocity sensor, the InnovaMass® Flow Meter computes the total fluid volume.

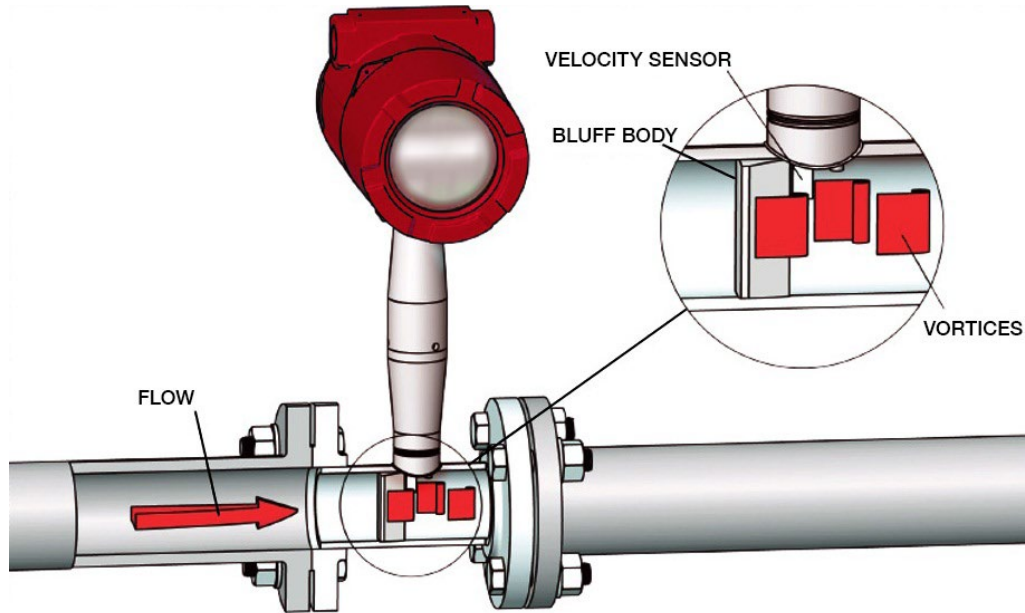

Figure 2 - Measurement Principle of Vortex Flow Meters

Vortex Frequency Sensing

The velocity sensor incorporates a piezoelectric element that senses the vortex frequency. This element detects the alternating lift forces produced by the Von Karman vortices flowing downstream of the vortex shedder bar. The alternating electric charge generated by the piezoelectric element is processed by the transmitter's electronic circuit to obtain the vortex shedding frequency. The piezoelectric element is highly sensitive and operates over a wide range of flows, pressures, and temperatures.

Flow Velocity Range

To ensure trouble-free operation, vortex flow meters must be correctly sized so that the flow velocity range through the meter lies within the measurable velocity range (with acceptable pressure drop) and the linear range.

The measurable range is defined by the minimum and maximum velocity using the following table.

	Gas	Liquid	
Vmin	$\sqrt{\frac{25}{\rho}}$ ft/s	1 ft/s	English (lb/ft ³)
Vmax			
0.5 in	175 ft/s	30 ft/s	
0.75 in	250 ft/s	30 ft/s	
1 in	250 ft/s	30 ft/s	
1.5 in and greater	300 ft/s	30 ft/s	
Vmin	$\sqrt{\frac{37}{\rho}}$ m/s	0.3 m/s	Metric (kg/m ³)
Vmax			
DN15	53 m/s	9.1 m/s	
DN20	76 m/s	9.1 m/s	
DN25	76 m/s	9.1 m/s	
DN40 and greater	91 m/s	9.1 m/s	

The linear range is defined by the Reynolds number. The Reynolds number is the ratio of the inertial forces to the viscous forces in a flowing fluid and is defined as:

$$Re = \frac{\rho V D}{\mu}$$

Where:

- Re = Reynolds Number
- ρ = Mass density of the fluid being measured
- V = Velocity of the fluid being measured
- D = Internal diameter of the flow channel
- μ = Viscosity of the fluid being measured

The Strouhal number is the other dimensionless number that quantifies the vortex phenomenon. The Strouhal number is defined as:

$$St = \frac{f d}{V}$$

Where:

- St = Strouhal Number
- f = Frequency of vortex shedding
- d = Shedder bar width
- V = Fluid velocity

As shown in Figure 3, InnovaMass® meters exhibit a constant Strouhal number across a large range of Reynolds numbers, indicating a consistent linear output over a wide range of flows and fluid types. Below this linear range, the intelligent electronics in InnovaMass® automatically corrects for the variation in the Strouhal number with the Reynolds number. The meter’s smart electronics corrects for this non-linearity via its simultaneous measurements of the process fluid temperature and pressure. This data is then used to calculate the Reynolds number in real time. InnovaMass® meters automatically correct down to a Reynolds number of 5,000.

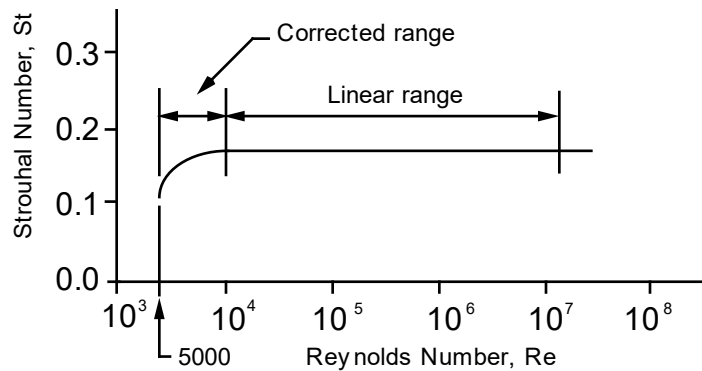

Figure 3 - Reynolds Number Range for the InnovaMass®

Pressure Drop

The pressure drop for series 241S insertion meters is negligible. The pressure drop for series 240S in-line meters is defined as:

$$\Delta P = .00024 \rho V^2 \quad \text{English units } (\Delta P \text{ in psi, } \rho \text{ in lb/ft}^3, V \text{ in ft/sec})$$

$$\Delta P = .000011 \rho V^2 \quad \text{Metric units } (\Delta P \text{ in bar, } \rho \text{ in kg/m}^3, V \text{ in m/sec})$$

Minimum Back Pressure

A minimum back pressure is required to prevent cavitation in the vortex flow meter when installed in liquid applications. Cavitation is a phenomenon wherein a liquid passing through a low pressure zone no longer can remain in the liquid phase and therefore partially flashes (or “boils”) into its vapor phase. The resulting two-phase flow degrades the liquid calibration accuracy. For some applications, a valve downstream of the flow meter may be required to increase the pressure in the meter, thereby avoiding cavitation. The following equation defines the minimum back pressure to prevent cavitation.

$$P = 2.9 \Delta P + 1.3 P_v$$

Where:

- P = Minimum line pressure five pipe diameters downstream of the flow meter required to avoid cavitation (psia or bara).
- ΔP = Permanent pressure loss across the flow meter (psia or bara).
- P_v = Liquid vapor pressure at actual flowing conditions (psia or bara).

Temperature Measurement

InnovaMass® Flow Meters use a 1000 ohm platinum resistance temperature detector (PRTD) to measure fluid temperature.

Pressure Measurement

InnovaMass® Flow Meters incorporate a solid-state pressure transducer isolated by a 316 stainless steel diaphragm. The transducer itself is micro-machined silicon, fabricated using integrated circuit processing technology. A nine-point pressure/temperature calibration is performed on every sensor. Digital compensation allows these transducers to operate within a 0.3% of full scale accuracy band within the entire ambient temperature range of -40°F to 140°F (-40 to 60°C). Thermal isolation of the pressure transducer ensures the same accuracy across the allowable process fluid temperature range of -330°F to 750°F (-200 to 400°C).

Flow Meter Configurations

InnovaMass® Vortex Mass Flow Meters are available in two model configurations:

- Series 240S/240S-R in-line flow meter (replaces a section of the pipeline)
- Series 241S insertion flow meter (requires a “cold” tap or a “hot” tap into an existing pipeline)

Both the in-line and insertion configurations are similar in that they both use identical electronics and have similar sensor heads. Besides installation differences, the main difference between an in-line flow meter and an insertion flow meter is their method of measurement.

For an in-line vortex flow meter, the shedder bar is located across the entire diameter of the flow body. Thus, the entire pipeline flow is included in the vortex formation and measurement. The sensing head,

which directly measures velocity, temperature and pressure is located just downstream of the shedder bar.

Insertion vortex flow meters have a shedder bar located across the diameter of a short tube. The velocity, temperature and pressure sensor are located within this tube just downstream of a built-in shedder bar. This entire assembly is called the insertion sensing head. It fits through any entry port with a 1.875 inch minimum internal diameter.

The sensing head of an insertion vortex flow meter directly monitors the velocity at a point in the cross-sectional area of a pipe, duct, or stack (referred to as “channels”). The velocity at a point in the pipe varies as a function of the Reynolds number. The insertion vortex flow meter computes the Reynolds number and then computes the total flow rate in the channel. The output signal of insertion meters is the total flow rate in the channel. The accuracy of the total flow rate computation depends on adherence to the piping installation requirements given in Chapter 2. If adherence to those guidelines cannot be met, contact the factory for specific installation advice.

Multivariable Options

The 240S and 241S models are available with the following options:

V, volumetric flowmeter; VT, velocity and temperature sensors; VTP, velocity, temperature, and pressure sensors; VT-EM energy output options; VTP-EM, energy options with pressure; VT-EP, external pressure transmitter input; VETEP, external RTD temperature input, external 4-20 mA input.

Line Size / Process Connections / Materials

The 240S non-reducing In-line models are built for line sizes ½ through 4-inch wafer or ½ through 12-inch flanged design using ANSI 150, 300, 600, 900, DIN PN16, 40, 63, or JIS 10K, 20K, 30K class flanges. These can be built with A105 carbon steel (1 ½ through 12 inch), 316/316L stainless steel, or Hastelloy C-276.

The 240S-R Reducing In-line models have face to face lengths that are different from 240S. The 240S-R In-line flanged or wafer model reduces by one pipe size to increase the velocity through the meter and is available for ANSI 150, 300, 600 or 900 class flanges and 316/316L stainless steel.

The 241S Insertion model can be used in line sizes 2 inch and greater and is built with a compression fitting or packing gland design using 2-inch NPT, or 2-inch flanged connections (ANSI 150, 300, 600, 900, DIN PN16, 40, 63, or JIS 10K, 20K, 30K class flanges). The packing gland design can be ordered with a permanent or removable retractor. The 241S Insertion model can be built with 316/316L stainless steel or Hastelloy C-276.

Flow Meter Electronics

InnovaMass® Flow Meter electronics are available mounted directly to the flow body, or remotely mounted. The electronics housing may be used indoors or outdoors, including wet environments. Available input power options are: DC loop powered (2-wire), DC powered, AC powered, or Ethernet powered. Three analog output signals are available for your choice of three of the five process variables: mass flow rate, volumetric flow rate, temperature, pressure, or fluid density. A pulse output signal for

remote totalization and MODBUS, HART, BACnet, and IP version of MODBUS/BACnet communications are also available.

InnovaMass® Flow Meters include a local 2 x 16 character LCD display housed within the enclosure. Local operation and reconfiguration is accomplished using six pushbuttons operated via finger touch. For hazardous locations, the six buttons can be operated with the electronics enclosure sealed using a hand-held magnet, thereby not compromising the integrity of the hazardous location certification.

The electronics include nonvolatile memory that stores all configuration information. The nonvolatile memory allows the flow meter to function immediately upon power up, or after an interruption in power. All flowmeters are calibrated and configured for the customer's flow application.

Chapter 2 Installation

Installation Overview

The InnovaMass® Vortex Flow Meter installations are simple and straightforward. Both the Series 240S In-Line and Series 241S Insertion type flow meter installations are covered in this chapter. After reviewing the installation requirements given below, see page 24 for Series 240S installation instructions. See page 28 for Series 241S installation instructions. Wiring instructions begin on page 42.

**Warning!**

Consult the flow meter nameplate for specific flow meter approvals before any hazardous location installation.

Flow Meter Installation Requirements

Before installing the flow meter, verify the installation site allows for these considerations:

1. Line pressure and temperature will not exceed the flow meter rating.
2. The location meets the required minimum number of pipe diameters upstream and downstream of the sensor head as illustrated in Figure 4.
3. Safe and convenient access with adequate overhead clearance for maintenance purposes.
4. Verify that the cable entry into the instrument meets the specific standard required for hazardous area installations. The cable entry device shall be of a certified flameproof type, suitable for the conditions of use and correctly installed. The degree of protection of at least IP66 to EN 60529 is only achieved if certified cable entries are used that are suitable for the application and correctly installed. Unused apertures shall be closed with suitable blanking elements.
5. For remote installations, verify the supplied cable length is sufficient to connect the flow meter sensor to the remote electronics.

Also, before installation check your flow system for anomalies such as:

- leaks
- valves or restrictions in the flow path that could create disturbances in the flow profile that might cause unexpected flow rate indications
- avoid areas where high RF, EMI, or other electrical interference may be present. Devices such as VFD's (variable frequency devices), large AC motors, etc.

Unobstructed Flow Requirements

Select an installation site that will minimize possible distortion in the flow profile. Valves, elbows, control valves and other piping components may cause flow disturbances. Check your specific piping condition against the examples shown below. In order to achieve accurate and repeatable performance install the flow meter using the recommended number of straight run pipe diameters upstream and downstream of the sensor.

Note: For liquid applications in vertical pipes, avoid installing with flow in the downward direction because the pipe may not be full at all points. Choose to install the meter with flow in the upward direction if possible.

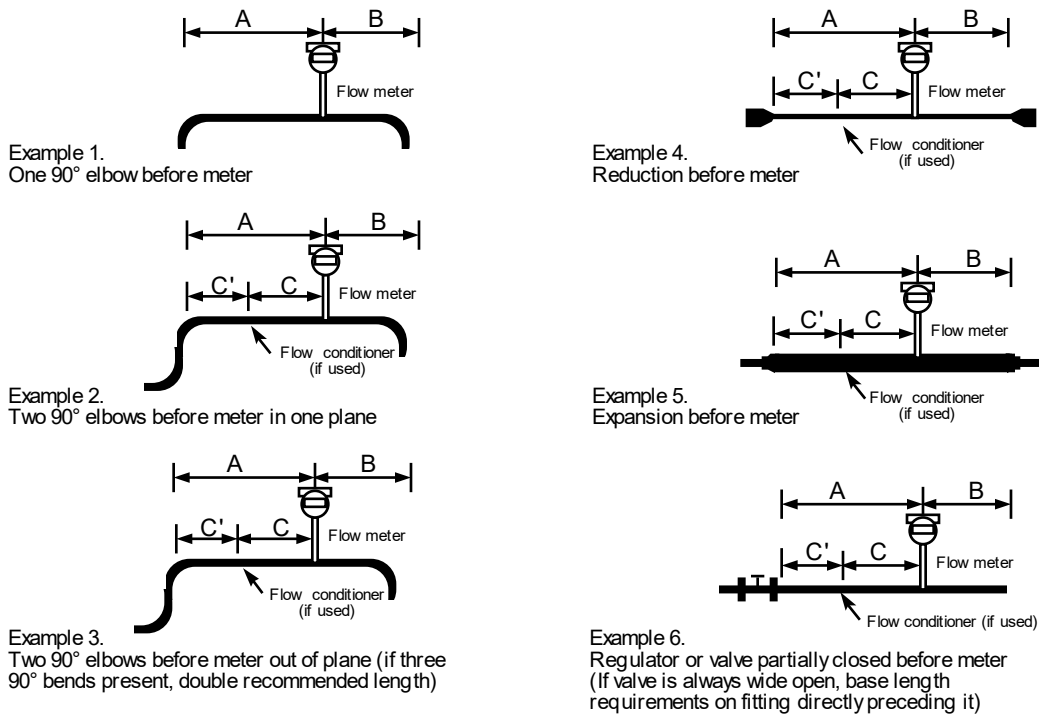

Example	Minimum Required Upstream Diameters				Minimum Required Downstream Diameters	
	No Flow Conditioner	With Flow Conditioner			No Flow Conditioner	With Flow Conditioner
	A	A	C	C'	B	B
1	10 D	N/A	N/A	N/A	5 D	5 D
2	15 D	10 D	5 D	5 D	5 D	5 D
3	30 D	10 D	5 D	5 D	10 D	5 D
4	10 D	10 D	5 D	5 D	5 D	5 D
5	20 D	10 D	5 D	5 D	5 D	5 D
6	30 D	10 D	5 D	5 D	10 D	5 D

D = Internal diameter of channel. N/A = Not applicable

Figure 4 - Recommended Pipe Length Requirements for Installation, Series 240S/241S

Recommended Meter Locations

Liquid Horizontal

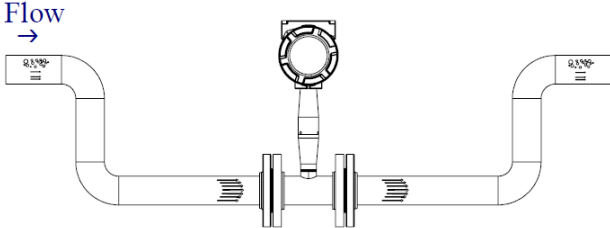

Liquid Vertical

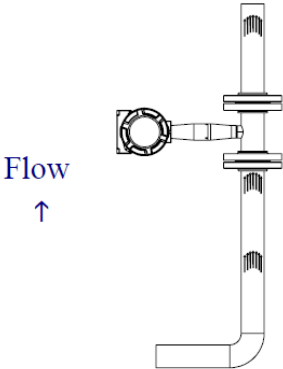

Gas or Steam Horizontal

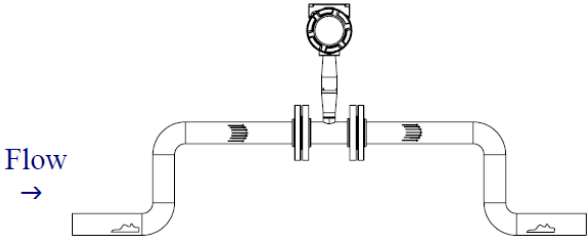

Gas or Steam Vertical

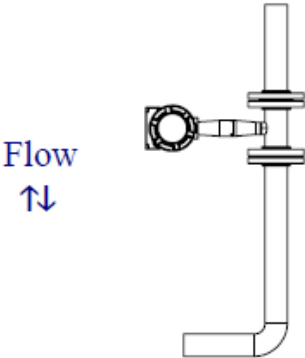

Series 240S In-Line Flow Meter Installation

Install the Series 240S In-Line Flow Meter between two conventional pipe flanges as shown in Figures 6 and 7.

The meter inside diameter is equal to the same size nominal pipe ID in schedule 80. For example, a 2” meter has an ID of 1.939” (2” schedule 80). **Do not install the meter in a pipe with an inside diameter smaller than the inside diameter of the meter.** For schedule 160 and higher pipe, a special meter is required. Consult the factory before purchasing the meter.

Series 240S Meters require customer-supplied gaskets. When selecting gasket material make sure that it is compatible with the process fluid and pressure ratings of the specific installation. Verify that the inside diameter of the gasket is larger than the inside diameter of the flow meter and adjacent piping. If the gasket material extends into the flow stream, it will disturb the flow and cause inaccurate measurements.

Flange Bolt Specifications

Stud bolt lengths may be calculated using the following equation:

$$L = \text{Meter face to face length} + 2 (\text{mounting flange thickness} + \text{flange raised face}) + 2 (\text{gasket thickness}) + 4 (\text{mounting nut thickness})$$

Refer to the mounting flange specification to select the correct stud bolt diameter.

The required bolt load for sealing the gasket joint is affected by several application-dependent factors; therefore, the required torque for each application may be different. Refer to the ASME Pressure Vessel Code guidelines for bolt tightening standards.

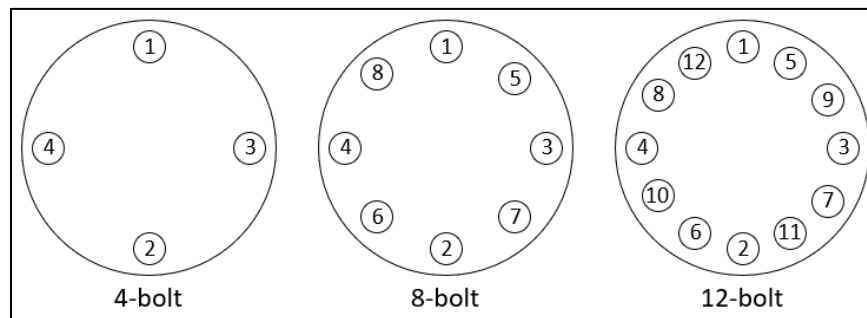

Figure 5 - Flange Bolt Torquing Sequence

Wafer-Style Flow Meter Installation

Install the wafer-style meter between two conventional pipe flanges of the same nominal size as the flow meter. If the process fluid is a liquid, make sure the meter is located where the pipe is always full. This may require locating the meter at a low point in the piping system. Note: Vortex flow meters are not suitable for two-phase flows (i.e., liquid and gas mixtures). For horizontal pipelines having a process temperature above 300° F, mount the meter at a 45 or 90-degree angle to avoid overheating the electronics enclosure. To adjust the viewing angle of the enclosure or display/keypad, see page 38 and 39.

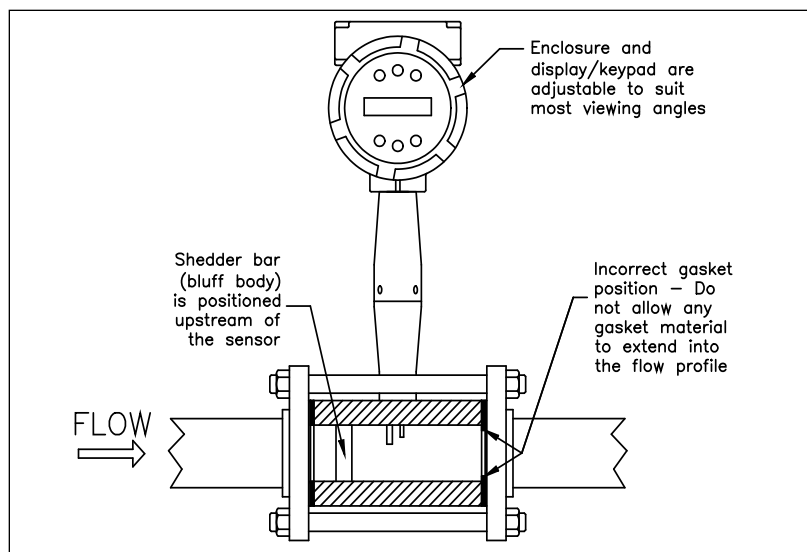

Figure 6 - Wafer-Style Flow Meter Installation

When installing the meter make sure the section marked with a flow arrow is positioned upstream of the outlet, with the arrow head pointing in the direction of flow (the mark is on the wafer adjacent to the enclosure mounting neck). This ensures that the sensor head is positioned downstream of the vortex shedder bar and is correctly aligned to the flow. Installing the meter opposite this direction will result in completely inaccurate flow measurement. To install the meter:



Caution!

When using toxic or corrosive gases, purge the line with inert gas for a minimum of four hours at full gas flow before installing the flow meter.

To install the meter:

1. Turn off the flow of process gas, liquid, or steam. Verify that the line is not pressurized. Confirm that the installation site meets the required minimum upstream and downstream pipe diameters.
2. Insert the studs for the bottom side of the meter body between the pipe flanges. Place the wafer-style meter body between the flanges with the end stamped with a flow arrow on the upstream side, with the arrow head pointing in the direction of flow. Center the meter body inside the diameter with respect to the inside diameter of the adjoining piping.
3. Position the gasket material between the mating surfaces. Make sure both gaskets are smooth and even with no gasket material extending into the flow profile. Obstructions in the pipeline will disturb the flow and cause inaccurate measurements.
4. Place the remaining studs between the pipe flanges. Tighten the nuts in the sequence shown in Figure 5. Check for leaks after tightening the flange bolts.

Flange-Style Flow Meter Installation

Install the flange-style meter between two conventional pipe flanges of the same nominal size as the flow meter. If the process fluid is a liquid, make sure the meter is located where the pipe is always full. This may require locating the meter at a low point in the piping system. Note: Vortex flow meters are not suitable for two-phase flows (i.e., liquid and gas mixtures). For horizontal pipelines having a process temperature above 300° F, mount the meter at a 45 or 90-degree angle to avoid overheating the electronics enclosure. To adjust the viewing angle of the enclosure or display/keypad, see page 40 and 41. NOTE: The meter must not be mounted in 5-7 O' Clock positions on the pipe.

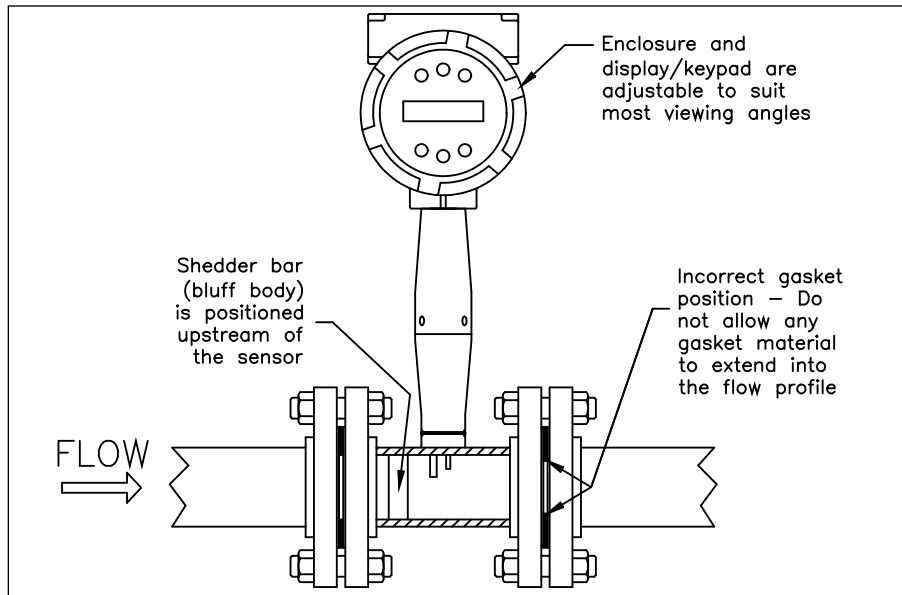

Figure 7 - Flange-Style Flow Meter Installation

When installing the meter make sure the flange marked with a flow arrow is positioned upstream of the outlet flange, with the arrow head pointing in the direction of flow (the mark is on the flange adjacent to the enclosure mounting neck). This ensures that the sensor head is positioned downstream of the vortex shedder bar and is correctly aligned to the flow. Installing the meter opposite this direction will result in completely inaccurate flow measurement.



Caution!

When using toxic or corrosive gases, purge the line with inert gas for a minimum of four hours at full gas flow before installing the flow meter.

To install the meter:

1. Turn off the flow of process gas, liquid, or steam. Verify that the line is not pressurized. Confirm that the installation site meets the required minimum upstream and downstream pipe diameters.
2. Seat the meter level and square on the mating connections with the flange stamped with a flow arrow on the upstream side, with the arrow head pointing in the direction of flow. Position a gasket in place

for each side. Make sure both gaskets are smooth and even with no gasket material extending into the flow profile. Obstructions in the pipeline will disturb the flow and cause inaccurate measurements.

3. Install bolts in both process connections. Tighten the nuts in the sequence shown in Figure 5. Check for leaks after tightening the flange bolts.

Series 241S Insertion Flow Meter Installation

Prepare the pipeline for installation using either a cold tap or hot tap method described on the following pages. Refer to a standard code for all pipe tapping operations. The following tapping instructions are general in nature and intended for guideline purposes only. Before installing the meter, review the mounting position and isolation valve requirements given below.

Mounting Position

Allow clearance between the electronics enclosure top and any other obstruction when the meter is fully retracted.

Isolation Valve Selection

An isolation valve is available as an option with Series 241S meters. If you supply the isolation valve, it must meet the following requirements:

1. A minimum valve bore diameter of 1.875 inches is required, and the valve's body size should be two inches. Normally, gate valves are used.
2. Verify that the valve's body and flange rating are within the flow meter's maximum operating pressure and temperature.
3. Choose an isolation valve with at least two inches existing between the flange face and the gate portion of the valve. This ensures that the flow meter's sensor head will not interfere with the operation of the isolation valve.

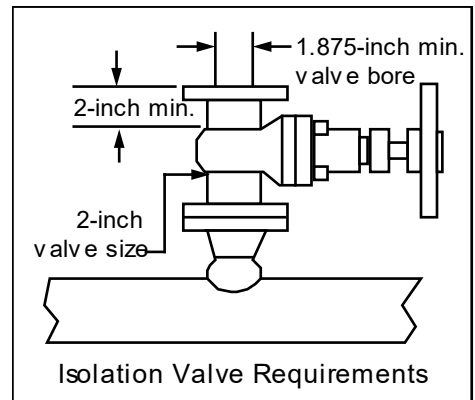

Cold Tap Guidelines

Refer to a standard code for all pipe tapping operations. The following tapping instructions are general in nature and intended for guideline purposes only.



Caution! When using toxic or corrosive gases, purge the line with inert gas for a minimum of four hours at full gas flow before installing the flow meter.



Warning! All flow meter connections, isolation valves and fittings for cold tapping must have the same or higher pressure rating as the main pipeline.

1. Turn off the flow of process gas, liquid or steam. Verify that the line is not pressurized.
2. Confirm that the installation site meets the minimum upstream and downstream pipe diameter requirements. See Figure 4.
3. Use a cutting torch or sharp cutting tool to tap into the pipe. The pipe opening must be at least 1.875 inches in diameter. Do not attempt to insert the sensor probe through a smaller hole.
4. Remove all burrs from the tap. Rough edges may cause flow profile distortions that could affect flow meter accuracy. Also, obstructions could damage the sensor assembly when inserting into the pipe.
5. After cutting, measure the thickness of the cut-out and record this number for calculating the insertion depth.
6. Weld the flow meter pipe connection on the pipe. Make sure this connection is within $\pm 5^\circ$ perpendicular to the pipe centerline.
7. Install the isolation valve (if used).
8. When welding is complete and all fittings are installed, close the isolation valve or cap the line. Run a static pressure check on the welds. If pressure loss or leaks are detected, repair the joint and re-test.
9. Connect the meter to the pipe process connection.
10. Calculate the sensor probe insertion depth and insert the sensor probe into the pipe as described on the following pages.

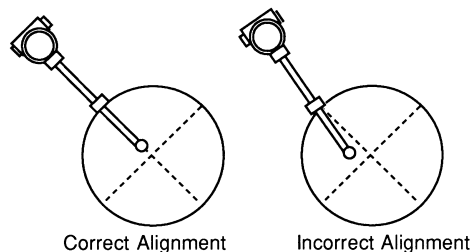

Hot Tap Guidelines

Refer to a standard code for all pipe tapping operations. The following tapping instructions are general in nature and intended for guideline purposes only.

	<p>Warning! Hot tapping must be performed by a trained professional. US regulations often require a hot tap permit. The manufacturer of the hot tap equipment and/or the contractor performing the hot tap is responsible for providing proof of such a permit.</p>
---	--

	<p>Warning! All flow meter connections, isolation valves, and fittings for hot tapping must have the same or higher pressure rating as the main pipeline.</p>
---	--

1. Confirm that the installation site meets the minimum upstream and downstream pipe diameter requirements.
2. Weld a two inch mounting adapter on the pipe. Make sure the mounting adapter is within $\pm 5^\circ$ perpendicular to the pipe centerline (see previous page). The pipe opening must be at least 1.875 inches in diameter.
3. Connect a two inch process connection on the mounting adapter.
4. Connect an isolation valve on the process connection. The valve's full open bore must be at least 1.875 inches in diameter.
5. Run a static pressure check on the welds. If pressure loss or leaks are detected, repair the joint and re-test.
6. Connect the hot tapping equipment to the isolation valve, open the isolation valve and drill at least a 1.875 inch diameter hole.
7. Retract the drill, close the isolation valve, and remove the hot tapping equipment.
8. Connect the flow meter to the isolation valve and open the isolation valve.
9. Calculate the sensor probe insertion depth and insert the sensor probe into the pipe as described on the following pages.

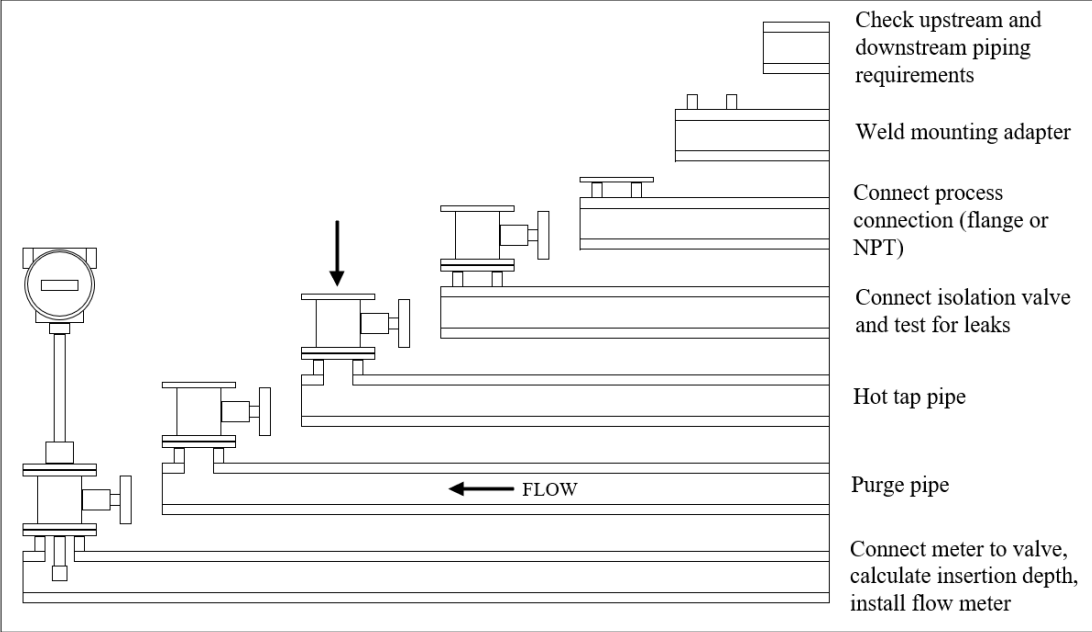

Figure 8 - Hot Tap Sequence

Flow Meter Insertion

The sensor head must be properly positioned in the pipe. For this reason, it is important that insertion length calculations are carefully followed. A sensor probe inserted at the wrong depth in the pipe will result in inaccurate readings.

Insertion flow meters are applicable to pipes 3 inches and larger. For pipe sizes 10 inches and smaller, the centerline of the meter's sensing head is located at the pipe's centerline. For pipe sizes larger than 10 inches, the centerline of the sensing head is located in the pipe's cross section 5 inches from the inner wall of the pipe, so its "wetted" depth from the wall to the centerline of the sensing head is 5 inches.

Insertion flow meters are available in three probe lengths:

Standard Probe configuration is used with most flow meter process connections. The length, S, of the stem is 29.47 inches.

Compact Probe configuration is used with compression fitting process connections. The length, S, of the stem is 13.1 inches.

12-Inch Extended Probe configuration is used with exceptionally lengthy flow meter process connections. The length, S, of the stem is 41.47 inches.

Use the Correct Insertion Formula

Depending on your flow meter's process connection, use the applicable insertion length formula and installation procedure as follows:

- Flow meters with a compression type connection (NPT or flanged) follow the instructions beginning on page 33.
- Flow meters with a packing gland type connection (NPT or flanged) configured with an insertion tool, follow the instructions beginning on page 35.
- Flow meters with a packing gland type connection (NPT or flanged) without an insertion tool, follow the instructions beginning on page 38.



Warning! An insertion tool must be used for any installation where a flow meter is inserted under pressure greater than 50 psig.

Installing Flow Meters with a Compression Connection*

Use the following formula to determine insertion length for flow meters (NPT and flanged) with a compression process connection. The installation procedure is given on the next page.

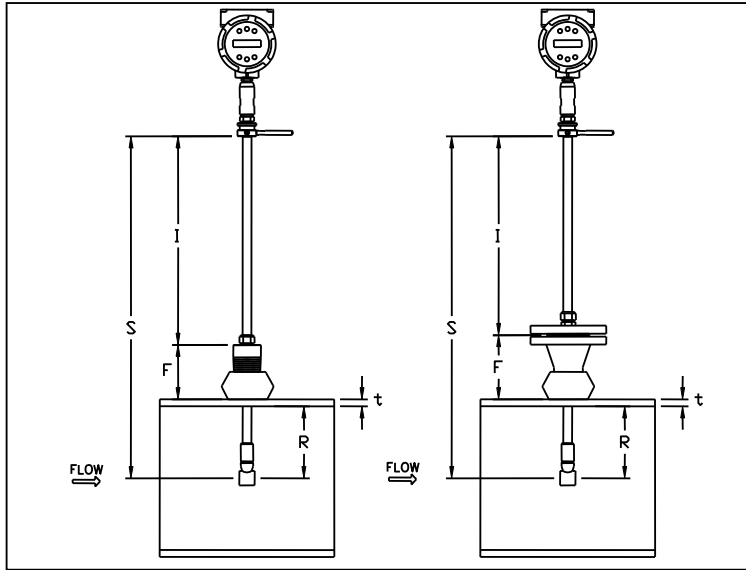

Figure 9 - Insertion Calculation (Compression Type)

Insertion Length Formula

$$I = S - F - R - t$$

Where:

I = Insertion length

S = Stem length – the distance from the center of the sensor head to the base of the enclosure adapter (S = 29.47 inches for standard probes; S = 13.1 inches for compact; S = 41.47 inches for 12-inch extended).

F = Distance from the raised face of the flange or top of NPT stem housing to the outside of the pipe wall.

R = Pipe inside diameter ÷ 2 for pipes ten inches and smaller.

R = Five inches for pipe diameters larger than ten inches.

t = Thickness of the pipe wall. Measure the disk cut-out from the tapping procedure or check a piping handbook for thickness.

Example:

To install a Series 241S meter with a standard probe (S = 29.47 inches) into a 14 inch schedule 40 pipe, the following measurements are taken:

$$F = 3 \text{ inches}$$

$$R = 5 \text{ inches}$$

$$t = 0.438 \text{ inches}$$

The insertion length for this example is 21.03 inches. Insert the stem through the fitting until an insertion length of 21.03 inches is measured with a ruler.

**All dimensions are in inches*

Insertion Procedure for Meters with a Compression Connection

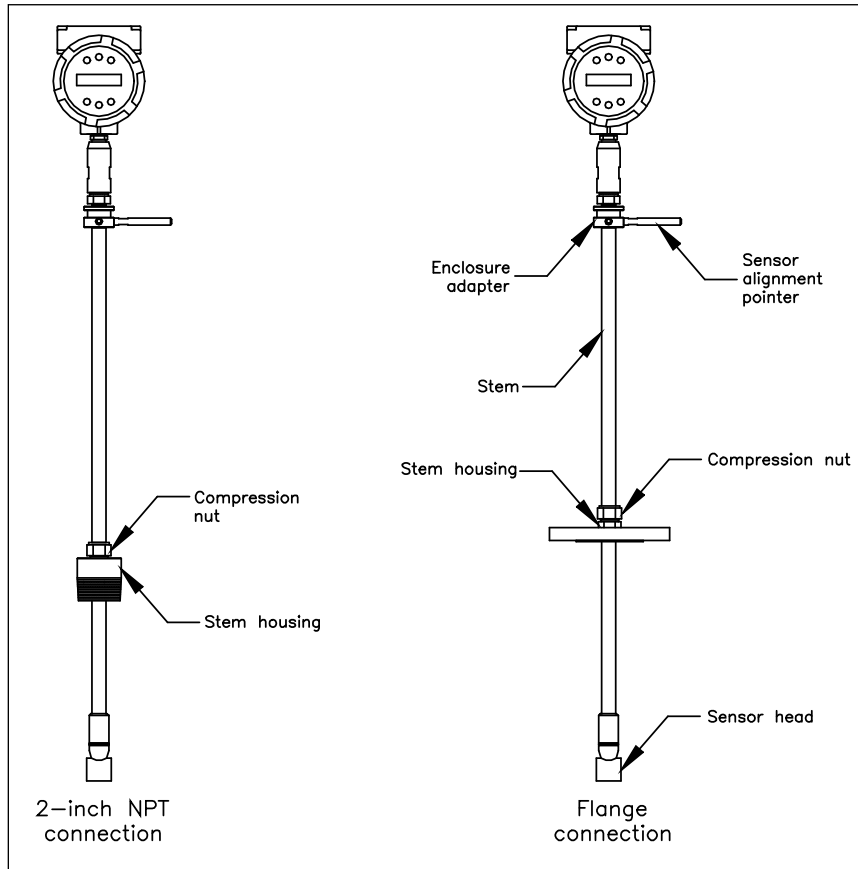

Figure 10 - Flow Meter with Compression Type Fitting

1. Calculate the required sensor probe insertion length.
2. Fully retract the stem until the sensor head is touching the bottom of the stem housing. Slightly tighten the compression nut to prevent slippage.
3. Bolt or screw the flow meter assembly into the process connection. Use Teflon tape or pipe sealant to improve the seal and prevent seizing on NPT styles.
4. Hold the meter securely while loosening the compression fitting. Insert the sensor into the pipe until the calculated insertion length, l , is measured between the base of the enclosure adapter and the top of the stem housing, or to the raised face of the flanged version. Do not force the stem into the pipe.
5. Align the sensor head using the sensor alignment pointer. Adjust the alignment pointer parallel to the pipe and pointing downstream.
6. Tighten the compression fitting to lock the stem in position. **When the compression fitting is tightened, the position is permanent.**



Caution!

The sensor alignment pointer must point downstream, in the direction of flow.



Warning!

To avoid serious injury, DO NOT loosen the compression fitting under pressure.

Installing Flow Meters with a Packing Gland Connection*

Use the formula below to determine the insertion depth for flow meters (NPT and flanged) equipped with an insertion tool. To install, see the next page for instructions for meters with a permanent insertion tool. For meters with a removable insertion tool, see page 37.

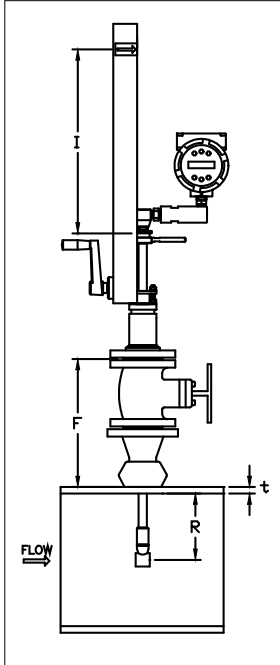

Insertion Length Formula

$$I = F + R - t - 1.35$$

Where:

- I = Insertion length
- F = Distance from the raised face of the flange or top of the process connection for NPT style meters to the top outside of the process pipe.
- R = Pipe inside diameter ÷ 2 for pipes ten inches and smaller.
- R = Five inches for pipe diameters larger than ten inches.
- t = Thickness of the pipe wall. (Measure the disk cut-out from the tapping procedure or check a piping handbook for thickness.)

Figure 11 - Insertion Calculation (Meters with Insertion Tool)

Example 1:

To install a Series 241S meter into a 14 inch schedule 40 pipe, the following measurements are taken:

- F = 12 inches
- R = 5 inches
- t = 0.438 inches

The insertion length for this example is 16.09 inches.

Example 2:

The length of thread engagement on the NPT style meters is also subtracted in the equation. The length of the threaded portion of the NPT meter is 1.18 inches. Measure the thread portion still showing after the installation and subtract that amount from 1.18 inches. This gives you the thread engagement length. If this cannot be measured use .55 inch for this amount.

- F = 12 inches
- R = 5 inches
- t = 0.438 inches

The insertion length for this example is 15.54 inches.

**All dimensions are in inches*

Insertion Procedure for Flow Meters with Permanent Insertion Tool

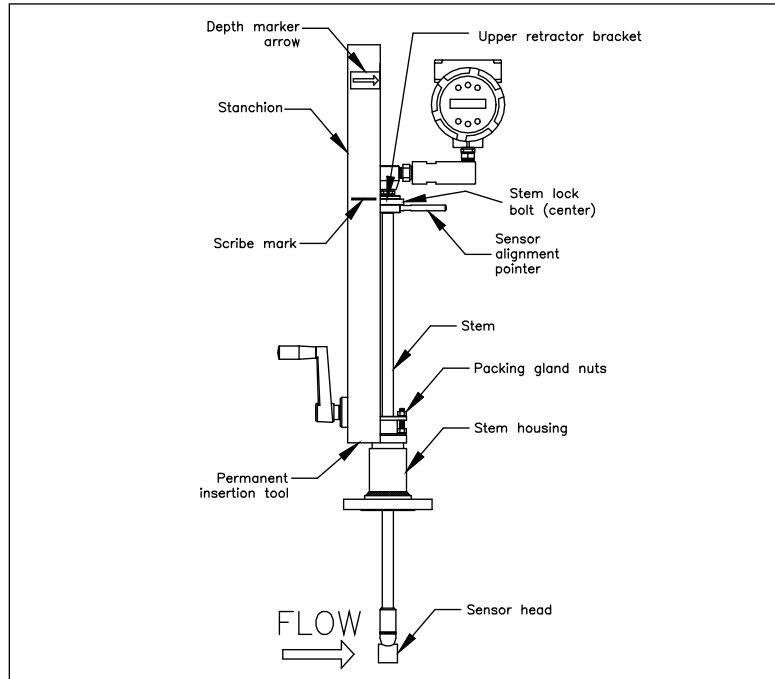

Figure 12 - Flow Meter with Permanent Insertion Tool



Caution!

The sensor alignment pointer must point downstream, in the direction of flow.



Note

If line pressure is above 500 psig, it could require up to 25 ft lb of torque to insert the flow meter. Do not confuse this with possible interference in the pipe.

1. Calculate the required sensor probe insertion length (see previous page). Measure from the depth marker arrow down the stanchion and scribe a mark at the calculated insertion depth.
2. Fully retract the flow meter until the sensor head is touching the bottom of the stem housing. Attach the meter assembly to the two inch full-port isolation valve, if used. Use Teflon tape or pipe sealant to improve seal and prevent seizing on NPT style.
3. Loosen the two packing gland nuts on the stem housing of the meter. Loosen the stem lock bolt adjacent to the sensor alignment pointer. Align the sensor head using the sensor alignment pointer. Adjust the alignment pointer parallel to the pipe and pointing downstream. Tighten the stem lock bolt to secure the sensor position.
4. Slowly open the isolation valve to the full open position. If necessary, slightly tighten the two packing gland nuts to reduce the leakage around the stem.
5. Turn the insertion tool handle clockwise to insert the sensor head into the pipe. Continue until the top of the upper retractor bracket aligns with the insertion length position scribed on the stanchion. Do not force the stem into the pipe.
6. Tighten the packing gland nuts to stop leakage around the stem. Do not torque over 20 ft-lb.

Insertion Procedure for Flow Meters with Removable Insertion Tool

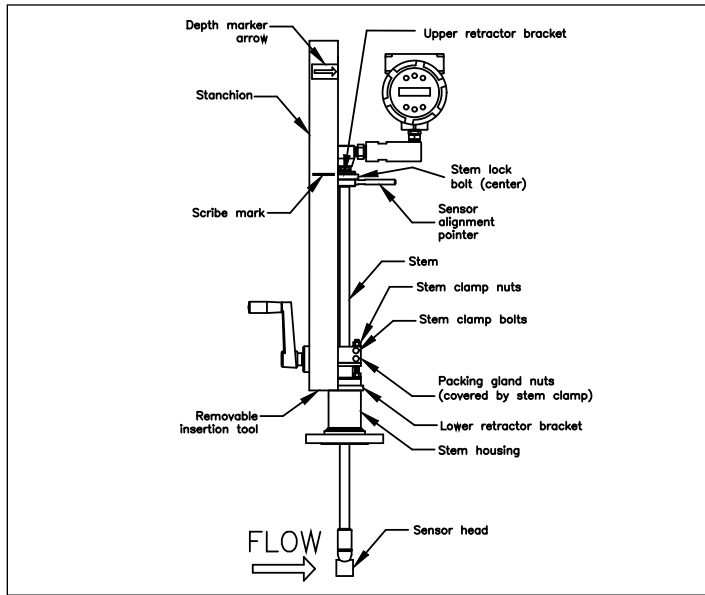

Figure 13 - Flow Meter with Removable Insertion Tool



Caution!

The sensor alignment pointer must point downstream, in the direction of flow.

1. Calculate the required sensor probe insertion length. Measure from the depth marker arrow down the stanchion and scribe a mark at the calculated insertion depth.
2. Fully retract the flow meter until the sensor head is touching the bottom of the stem housing. Attach the meter assembly to the two inch full-port isolation valve, if used. Use Teflon tape or pipe sealant to improve seal and prevent seizing on NPT style.
3. Remove the two top stem clamp nuts and loosen two stem clamp bolts. Slide the stem clamp away to expose the packing gland nuts.
4. Loosen the two packing gland nuts. Loosen the stem lock bolt adjacent to the sensor alignment pointer. Align the sensor head using the sensor alignment pointer. Adjust the alignment pointer parallel to the pipe and pointing downstream. Tighten the stem lock bolt to secure the sensor position.
5. Slowly open the isolation valve to the full open position. If necessary, slightly tighten the two packing gland nuts to reduce the leakage around the stem.
6. Turn the insertion tool handle clockwise to insert the stem into the pipe. Continue until the top of the upper retractor bracket lines up with the insertion length mark scribed on the stanchion. Do not force the stem into the pipe.
7. Tighten the packing gland nuts to stop leakage around the stem. Do not torque over 20 ft-lbs.
8. Slide the stem clamp back into position. Torque stem clamp bolts to 15 ft-lbs. Replace the stem clamp nuts and torque to 10-15 ft-lbs.
9. To separate the insertion tool from the flow meter, remove four socket head cap bolts securing the upper and lower retractor brackets. Remove the insertion tool.



Note

If line pressure is above 500 psig, it could require up to 25 ft lb of torque to insert the flow meter. Do not confuse this with possible interference in the pipe.

Installation of Meters with Packing Gland Connection (No Insertion Tool) *

Use the following formula to determine insertion depth for meters with a packing gland connection (NPT and flanged) without an insertion tool.

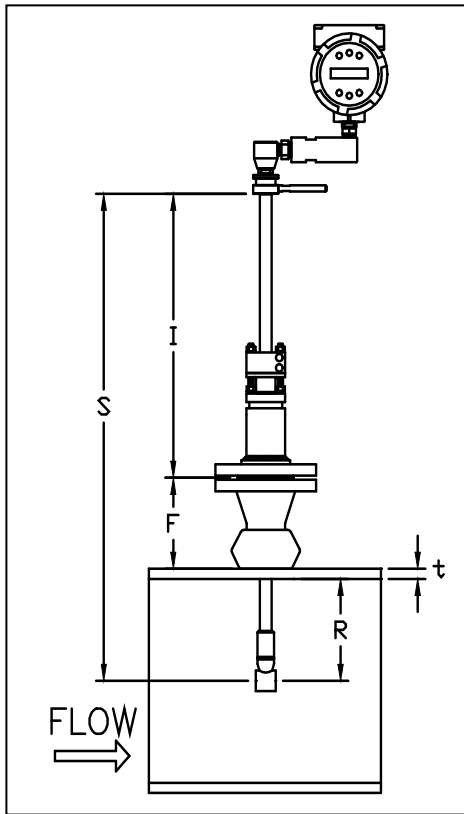

Figure 14 - Insertion Calculation (Meters without Insertion Tool)

Insertion Length Formula

$$I = S - F - R - t$$

Where:

- I = Insertion length
- S = Stem length – the distance from the center of the sensor head to the base of the enclosure adapter (S = 29.47 inches for standard probes; S = 41.47 inches for 12 inch extended probes).
- F = Distance from the raised face of the flange or top of NPT stem housing to the outside of the pipe wall.
- R = Pipe inside diameter ÷ 2 for pipes ten inches and smaller.
- R = Five inches for pipe diameters larger than ten inches.
- t = Thickness of the pipe wall. (Measure the disk cut-out from the tapping procedure or check a piping handbook for thickness.)

Example:

To install a Series 241S Flow Meter with a standard probe (S = 29.47) into a 14 inch schedule 40 pipe, the following measurements are taken:

- F = 3 inches
- R = 5 inches
- t = 0.438 inches

The example insertion length is 21.03 inches.

**All dimensions are in inches.*

Insertion Procedure for Flow Meters with Packing Gland Connection (No Insertion Tool)

	<p>Warning! The line pressure must be less than 50 psig for installation.</p>
---	--

	<p>Caution! The sensor alignment pointer must point downstream, in the direction of flow.</p>
---	--

1. Calculate the required sensor probe insertion length.
2. Fully retract the stem until the sensor head is touching the bottom of the stem housing. Remove the two top stem clamp nuts and loosen two stem clamp bolts. Slide the stem clamp away to expose the packing gland nuts. Loosen the two packing gland nuts.
3. Align the sensor head using the sensor alignment pointer. Adjust the alignment pointer parallel to the pipe and pointing downstream.
4. Insert the sensor head into the pipe until insertion length, l , is achieved. Do not force the stem into the pipe.
5. Tighten the packing gland nuts to stop leakage around the stem. Do not torque over 20 ft-lbs.
6. Slide the stem clamp back into position. Torque stem clamp bolts to 15 ft-lbs. Replace the stem clamp nuts and torque to 10-15 ft-lbs.

Adjusting Meter Orientation

Depending on installation requirements, you may need to adjust the meter orientation. There are two adjustments available. The first rotates the position of the LCD display/keypad and is available on both in-line and insertion meters. The second is to rotate the enclosure position. This adjustment is only allowed on Series 240S In-Line meters.

Display/Keypad Adjustment (All Meters)

The orientation of the display/keypad may be changed in 90 degree increments for easier viewing.

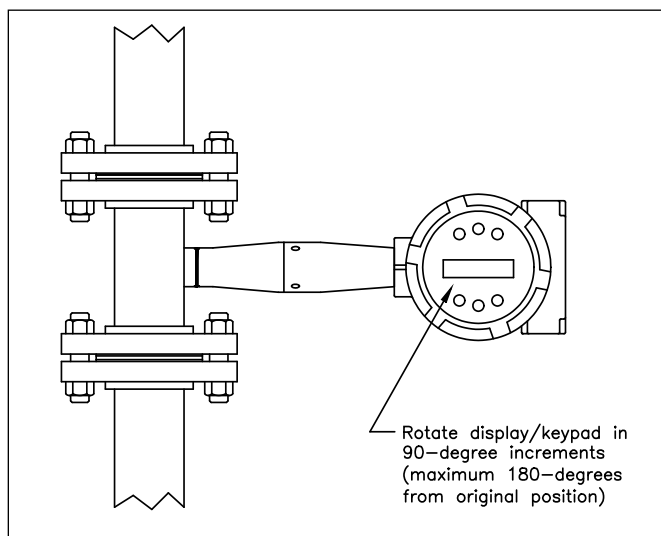

Figure 15 - Display/Keypad Viewing Adjustment

To adjust the display:



Warning!

The electronics boards are electrostatically sensitive. Wear a grounding wrist strap and make sure to observe proper handling precautions required for static-sensitive components.

1. Disconnect power to the flow meter.
2. Loosen the small set screw which secures the electronics enclosure cover. Unscrew and remove the window cover.
3. Loosen the 4 captive screws on the electronic display board.
4. Carefully pull the display/microprocessor board away from the meter standoffs. Make sure not to damage the connected ribbon cable.
5. Rotate the display/microprocessor board to the desired position. Maximum turn, two positions left or two positions right (180-degrees).
6. Align the board with the captive screws. Check that the ribbon cable is folded neatly behind the board with no twists or crimps.
7. Tighten the screws. Replace the cover and set screw. Restore power to the meter.

Enclosure Adjustment (Series 240S Only)

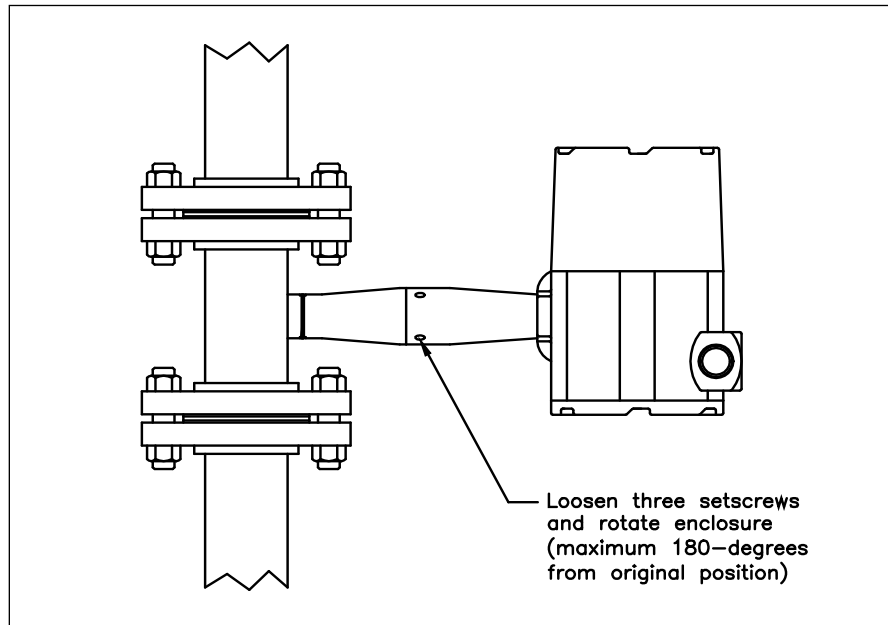

Figure 16 - Enclosure Viewing Adjustment

To avoid damage to the sensor wires, do not rotate the enclosure beyond 180-degrees from the original position. To adjust the enclosure:

1. Remove power to the flow meter.
2. Loosen the three set screws shown above. Cautiously rotate the display to the desired position (maximum 180-degrees).
3. Tighten the three set screws. Restore power to the meter.



Loop Power Flow Meter Wiring Connections

The NEMA 4X enclosure contains an integral wiring compartment with one terminal block (located in the smaller end of the enclosure). Two 3/4-inch female NPT conduit entries are available for separate power and signal wiring. For all hazardous area installations, only suitable certified cable glands, blanking plugs or thread adapters may be used. The cable entry device shall be of a certified flameproof type, suitable for the conditions of use and correctly installed. The degree of protection of at least IP66 to EN 60529 is only achieved if certified cable entries are used that are suitable for the application and correctly installed. Unused apertures shall be closed with suitable blanking elements. If conduit seals are used, they must be installed within 18 inches (457 mm) of the enclosure.

Warning!

To avoid potential electric shock, follow National Electric Code safety practices or your local code when wiring this unit to a power source and to peripheral devices. Failure to do so could result in injury or death. All wiring procedures must be performed with the power off.

Use a Class 2 isolated power supply that is grounded, provides DC output, and has no more than 10% output ripple.

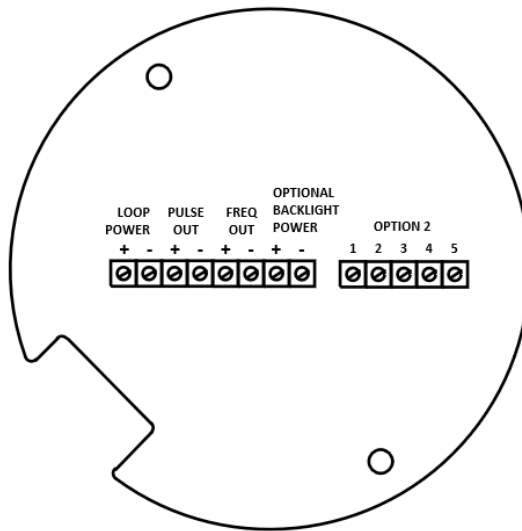

Figure 17 - Loop Power Wiring Terminals



Warning!

A power switch is not provided with this meter, an approved switch meeting the power requirements listed in Appendix A must be provided by the user. It must be easily accessible and marked as the disconnect for the flow meter.

Only the connectors supplied with the meter are to be used for connecting wiring.

If the equipment is used in a manner not specified the protection provided by the equipment may be impaired.

Input Power Connections

To access the wiring terminal blocks, locate and loosen the small set screw which locks the small enclosure cover in place. Unscrew the cover to expose the terminal block.

Connect 4-20 mA loop power (12 to 36 VDC at 25 mA, 1W max.) to the +Loop Power and – Loop Power terminals on the terminal block. Torque all connections to 4.43 to 5.31 in-lbs (0.5 to 0.6 Nm). The DC power wire size must be 20 to 12 AWG with the wire stripped 1/4 inch (7 mm).



Caution!

The DC wire insulation temperature rating must meet or exceed 85°C (185°F), maximum operating voltage 300 VRMS.

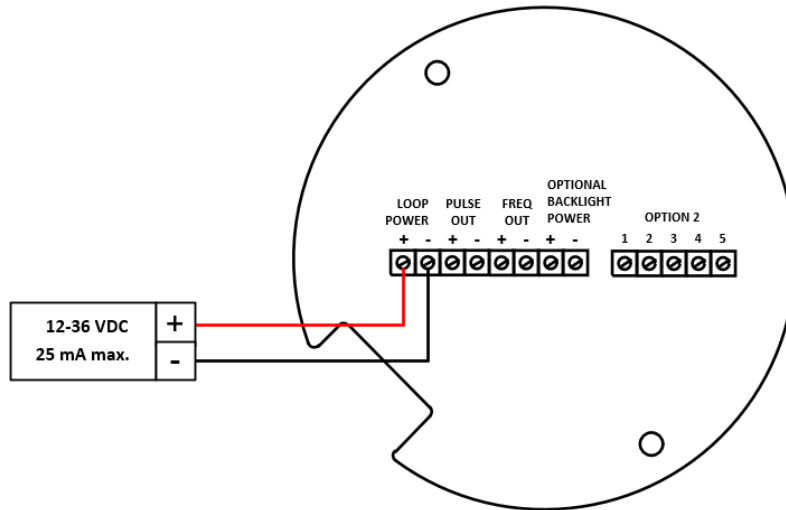

Figure 18 - DC Power Connections

4-20 mA Output Connections

The InnovaMass® meter has a single 4-20 mA loop. The 4-20 mA loop current is controlled by the meter electronics. The electronics must be wired in series with the sense resistor or current meter. The current control electronics require 12 volts at the input terminals to operate correctly.

The maximum loop resistance (load) for the current loop output is dependent upon the supply voltage and is given in Figure 19. The 4-20 mA loop is optically isolated from the flow meter electronics.

R_{load} is the total resistance in the loop, including the wiring resistance ($R_{load} = R_{wire} + R_{sense}$). To calculate R_{max} , the maximum R_{load} for the loop, subtract the minimum terminal voltage from the supply voltage and divide by the maximum loop current, 20 mA. Thus:

$$\text{The maximum resistance } R_{load} = R_{max} = (V_{supply} - 12V) / 0.020 \text{ A}$$

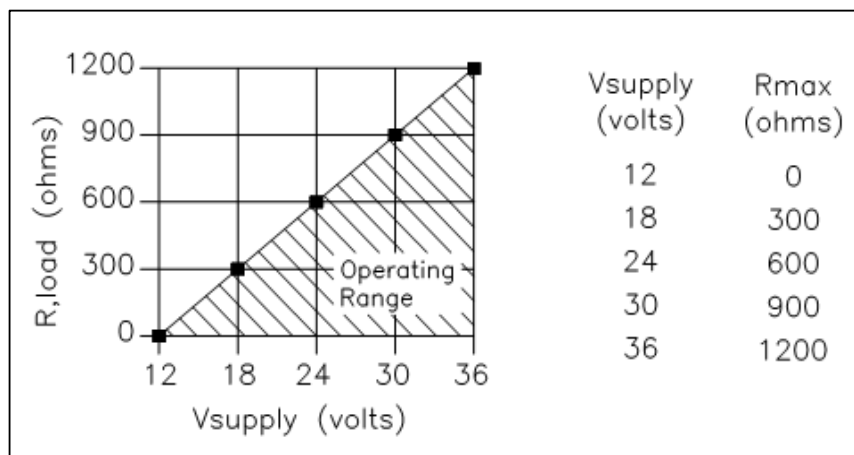

Figure 19 - Load Resistance Versus Input Voltage

The current loop range is 3.8 to 20.5 mA.

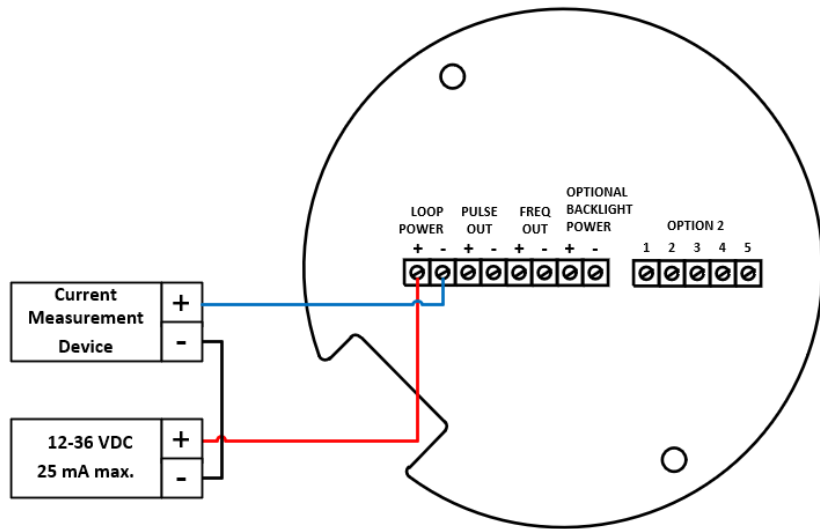

Figure 20 - Loop Power 4-20 mA Wiring Diagram

Pulse Output Connections

The pulse output is used for a remote counter. When the preset volume or mass (defined in the totalizer settings, see page 78) has passed the meter, the output provides a 50 millisecond square pulse.

The pulse output requires a separate 5 to 36 VDC power supply. The pulse output optical relay is a normally-open single-pole relay. The relay can conduct a current up to 40 mA. It is isolated from the meter electronics and power supply.

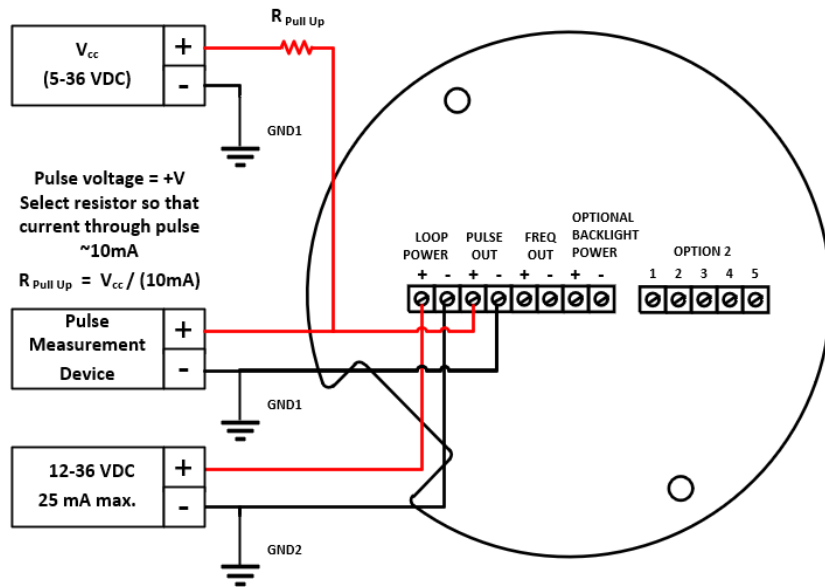

Figure 21 - Isolated Pulse Output Using External Power Supply

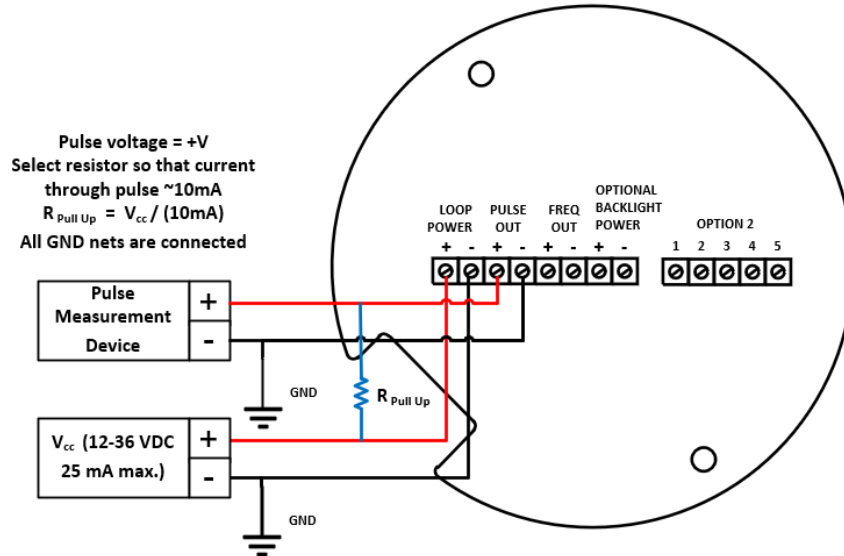

Figure 22 - Non-Isolated Pulse Output Using Meter Power Supply

Frequency Output Connections

The frequency output is used for a remote counter. It can be scaled to output a 1 to 10 kHz signal proportional to mass or volume flow, temperature, pressure or density. Scaled frequency will need to be set in the Output Menu (see page 72).

The frequency output requires a separate 5 to 36 VDC power supply. The frequency output optical relay is a normally-open single-pole relay. The output can conduct a current up to 40 mA. It is isolated from the meter electronics and power supply.

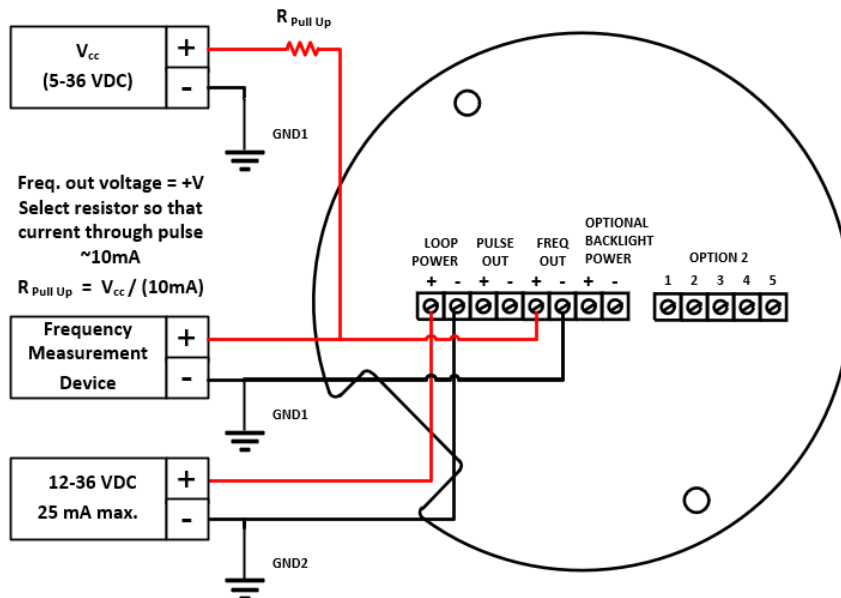

Figure 23 - Isolated Frequency Output Using External Power Supply

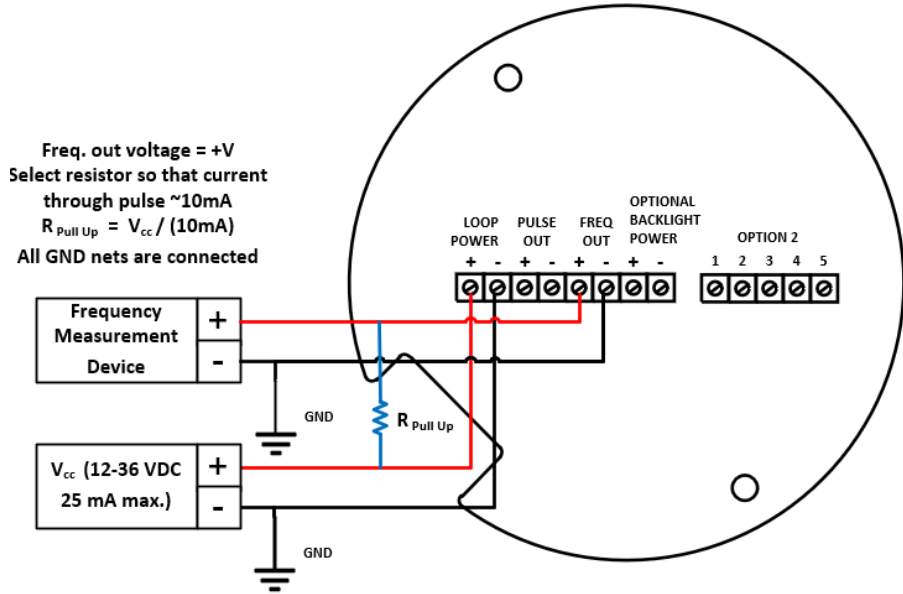

Figure 24 - Non-Isolated Frequency Output Using Meter Power Supply

Optional Backlight Connection

The loop power meter has an optional backlight connection provided. It is intended to be powered by a separate 12 to 36 VDC at 35 mA max. power supply or by the pulse power input.

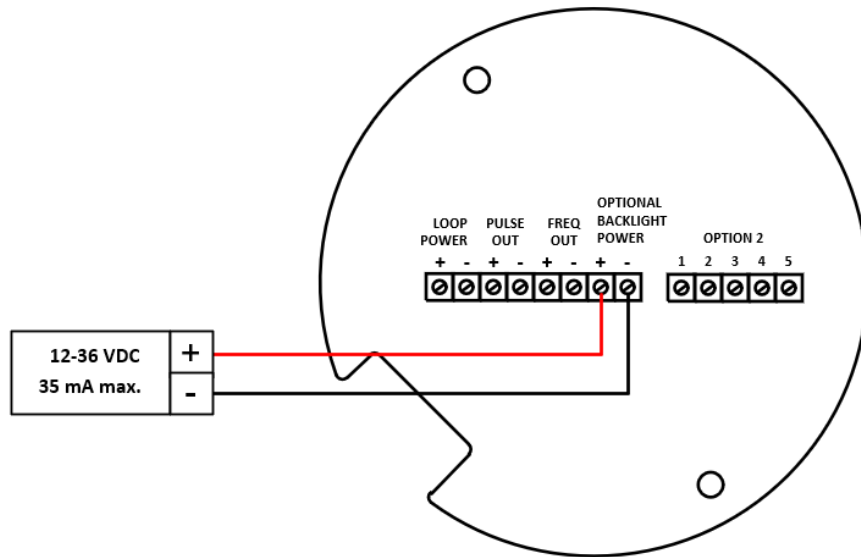



Figure 25 – Optional Backlight Using External Power Supply

Remote Electronics Wiring

The remote electronics enclosure should be mounted in a convenient, easy to reach location. For hazardous location installations, make sure to observe agency requirements for installation. Allow some

slack in the interface cable between the junction box and the remote electronics enclosure. To prevent damage to the wiring connections, do not put stress on the terminations at any time.

The meter is shipped with temporary strain relief glands at each end of the cable. Disconnect the cable from the meter’s terminal block inside the junction box – not at the remote electronics enclosure. Remove both glands and install appropriate conduit entry glands and conduit. The cable entry device shall be of a certified flameproof type, suitable for the conditions of use and correctly installed. The degree of protection of at least IP66 to EN 60529 is only achieved if certified cable entries are used that are suitable for the application and correctly installed. Unused apertures shall be closed with suitable blanking elements. When installation is complete, re-connect each labeled wire to the corresponding terminal position on the junction box terminal block. Make sure to connect each wire pair’s shield.

 **Note:** Incorrect connection will cause the meter to malfunction.

 **Note:** Numeric code on junction box label matches wire labels.

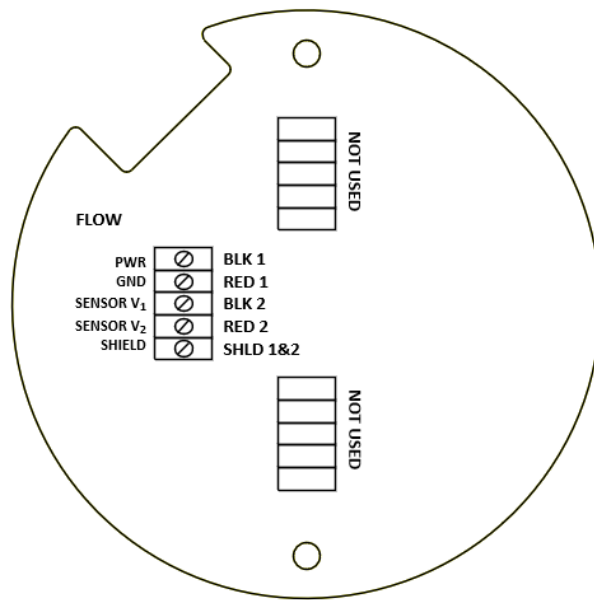

Figure 26 - Loop Power Volumetric Flowmeter Junction Box Sensor Connections

Wires enter the flow connector from the left side of the connector shown above.

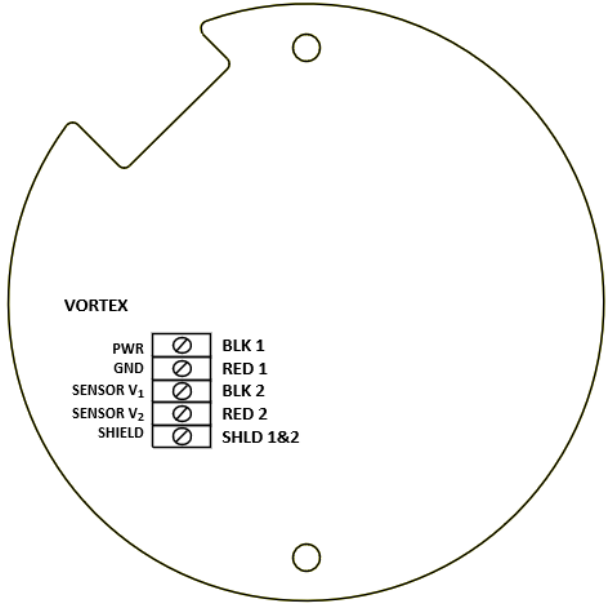

Figure 27 - Loop Power Volumetric Flowmeter Junction Box Sensor Connections Supplied Prior to Jan. 1, 2014

Wires enter the flow connector from the right side of the connector shown above.

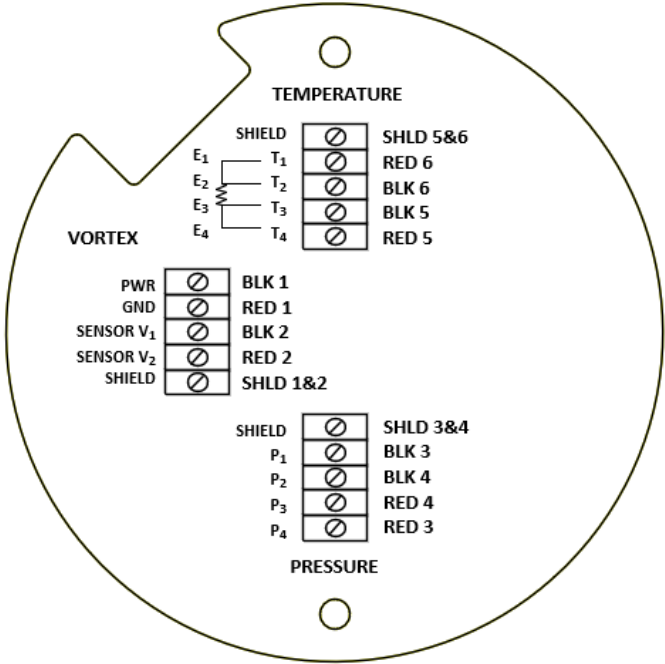

Figure 28 - Loop Power Mass Flowmeter Junction Box Sensor Connections

High Power Meter Wiring Connections



Warning!

To avoid potential electric shock, follow National Electric Code safety practices or your local code when wiring this unit to a power source and to peripheral devices. Failure to do so could result in injury or death. All AC power connections must be in accordance with published CE directives. All wiring procedures must be performed with the power off.

The NEMA 4X enclosure contains an integral wiring compartment with one terminal block (located in the smaller end of the enclosure). Two 3/4-inch female NPT conduit entries are available for separate power and signal wiring. For all hazardous area installations, only suitable certified cable glands, blanking plugs or thread adapters may be used. The cable entry device shall be of a certified flameproof type, suitable for the conditions of use and correctly installed. The degree of protection of at least IP66 to EN 60529 is only achieved if certified cable entries are used that are suitable for the application and correctly installed. Unused apertures shall be closed with suitable blanking elements. If conduit seals are used, they must be installed within 18 inches (457 mm) of the enclosure. There are two options for powering the POE version meters: external DC Power and POE option.

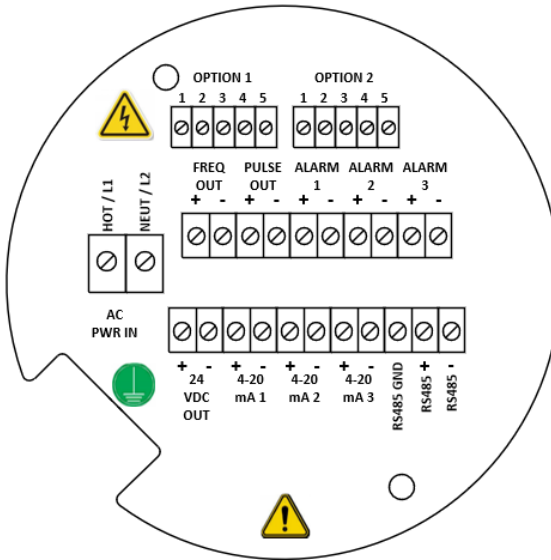

Figure 29 - AC Wiring Terminals



Warning!

A power switch is not provided with this meter, an approved switch meeting the power requirements listed in Appendix A must be provided by the user. It must be easily accessible and marked as the disconnect for the flow meter.

Only the connectors supplied with the meter are to be used for connecting wiring.

If the equipment is used in a manner not specified the

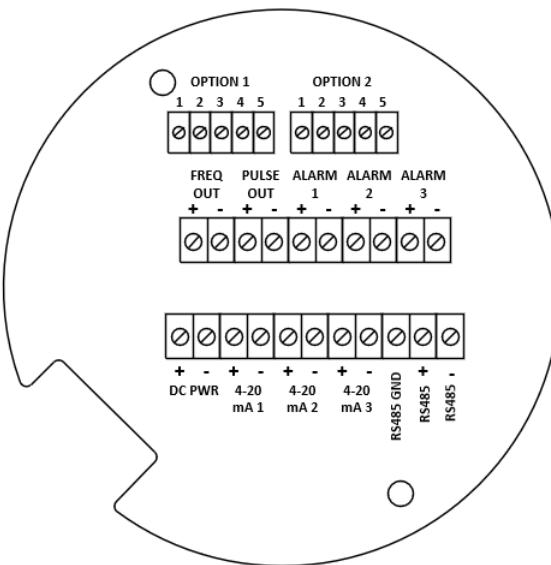

Figure 30 - DC Wiring Terminals

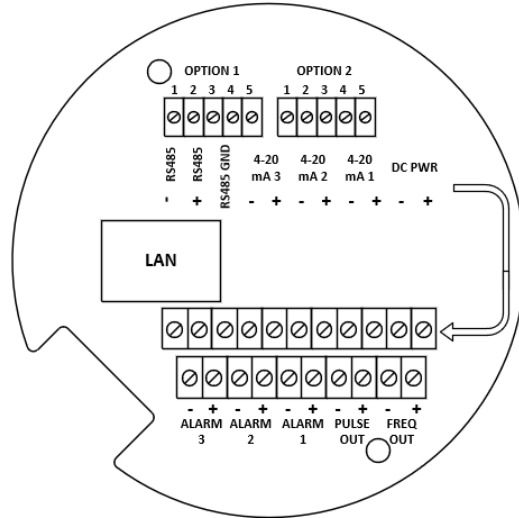

Figure 31 - POE Wiring Terminals

Input Power Connections

To access the wiring terminal blocks, locate and loosen the small set screw which locks the small enclosure cover in place. Unscrew the cover to expose the terminal block.



AC Power Wiring

The AC power wire size must be 20 to 10 AWG with the wire stripped 1/4 inch (7 mm). The wire insulation temperature must meet or exceed 90°C (194°F). Connect 100 to 240 VAC (5 W maximum) to the Hot and Neutral terminals on the terminal block. Connect the ground wire to the safety ground lug. Torque all connections to 4.43 to 5.31 in-lbs (0.5 to 0.6 Nm). Use a separate conduit entry for signal lines to reduce the possibility of AC noise interference.

Caution!

The AC wire insulation temperature rating must meet or exceed 90°C (194°F), maximum operating voltage 600 VRMS.

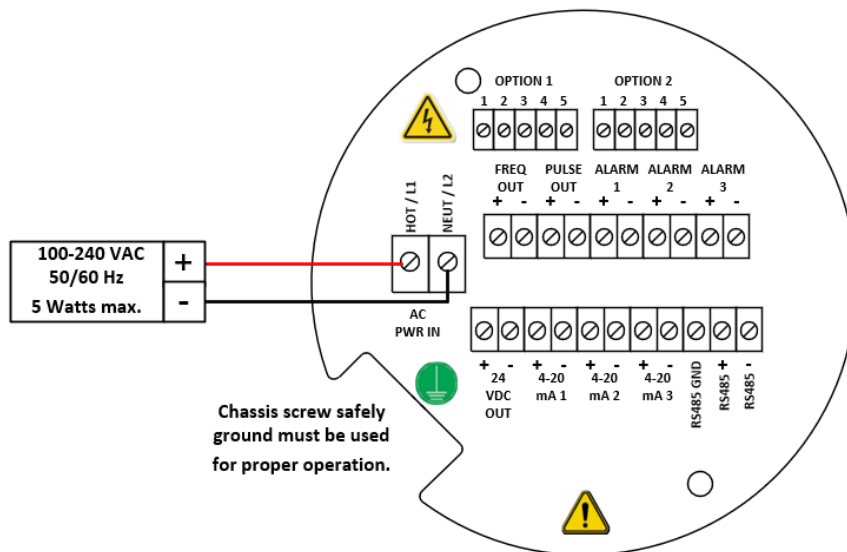

Figure 32 - AC Power Connections



Warning!

Use a Class 2 isolated power supply that is grounded, provides DC output, and has no more than 10% output ripple.

A power switch is not provided with this meter, an approved switch meeting the power requirements listed in Appendix A must be provided by the user. It must be easily accessible and marked as the disconnect for the flow meter.

Only the connectors supplied with the meter are to be used for connecting wiring.

If the equipment is used in a manner not specified the protection provided by the equipment may be impaired.

DC Power Wiring

The DC power wire size must be 20 to 12 AWG with the wire stripped 1/4 inch (7 mm). Connect 12 to 36 VDC (300 mA, 9 W maximum) to the +DC Pwr and -DC Pwr terminals on the terminal block.

Torque all connections to 4.43 to 5.31 in-lbs (0.5 to 0.6 Nm).

Alternatively, POE injector may be used for example (TRENDnet TPE-115Gi).

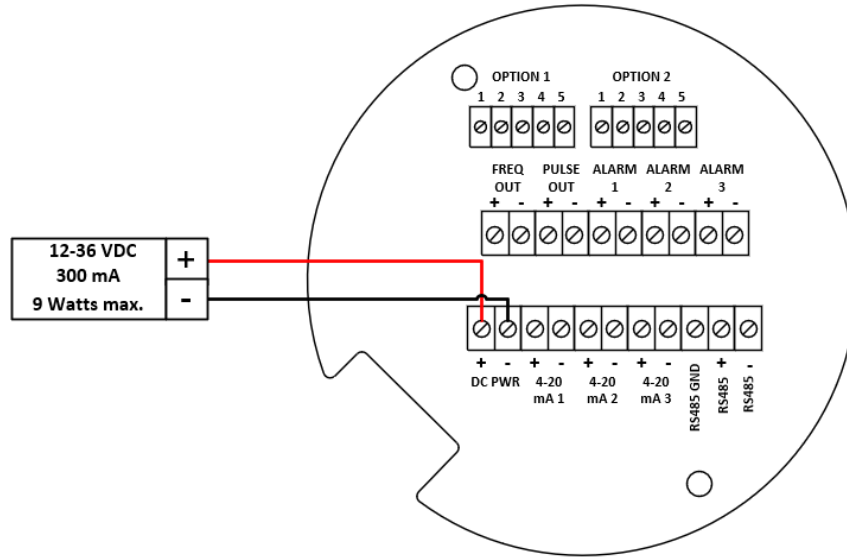

Figure 33 - DC Power Connections



Caution!

The DC wire insulation temperature rating must meet or exceed 85°C (185°F), maximum operating voltage 300 VRMS.

Alternatively, POE injector may be used for example (TRENDnet TPE-115Gi).

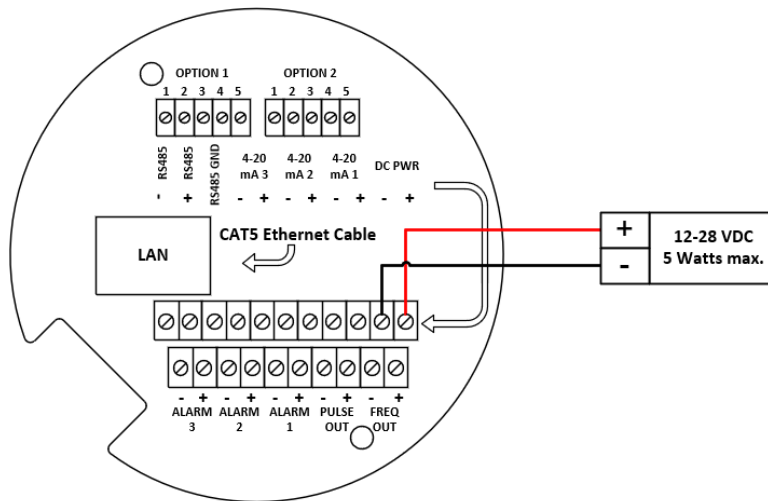

Figure 34 - DC POE Power Connections

POE Power Wiring

Connect the unit with the Ethernet cable to POE enable Ethernet switch (POE option does not require a separate power supply).

Plug Ethernet drop off cable from your Local Area Network (LAN) switch to LAN connector of Sierra meter. You should see a blinking orange LED and a solid green on the front of the LAN connector of the meter when the CAT5 Ethernet cable is plugged in and communicating.

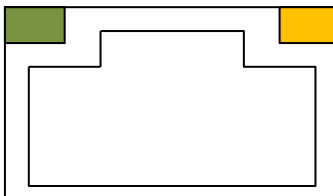

Figure 35 - Front of the LAN Connector

4-20 mA Output Connections

The DC wire insulation temperature rating must meet or exceed 85°C (185°F), maximum operating voltage 300 VRMS operate correctly.

The maximum loop resistance (load) for the current loop output is dependent upon the supply voltage and is given in Figure 36. The 4-20 mA loop is optically isolated from the flow meter electronics.

R_{load} is the total resistance in the loop, including the wiring resistance ($R_{load} = R_{wire} + R_{sense}$). To calculate R_{max} , the maximum R_{load} for the loop, subtract the minimum terminal voltage from the supply voltage and divide by the maximum loop current, 20 mA. Thus:

$$\text{The maximum resistance } R_{load} = R_{max} = (V_{supply} - 12V) / 0.020 A$$

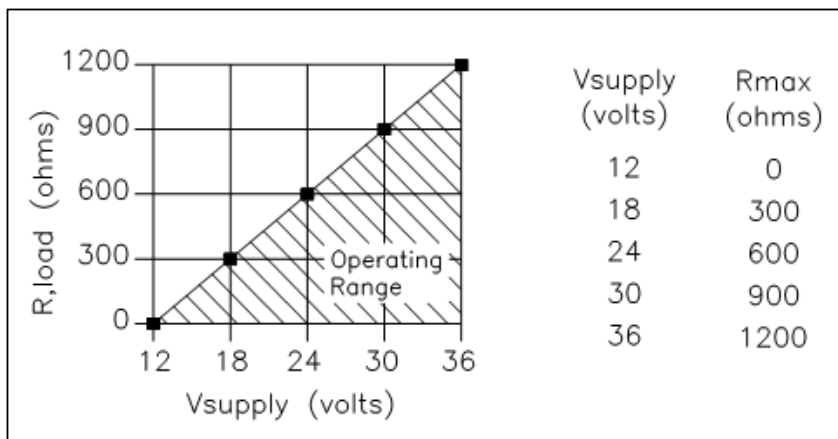

Figure 36 - Load Resistance Versus Input Voltage

The current loop range is 3.8 to 20.5 mA. See Figures 37 through 40 for wiring options.

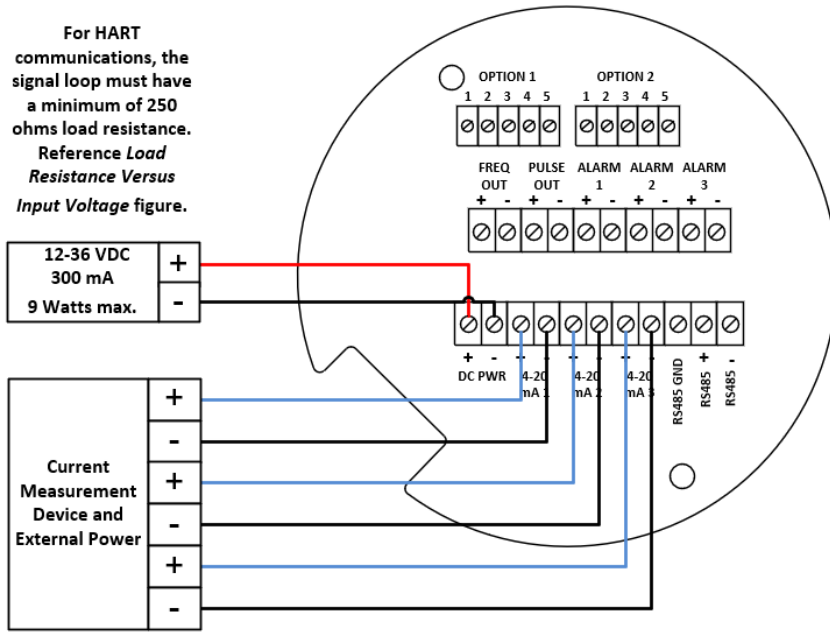

Figure 37 - Isolated 4-20mA Output Using External Power Supply

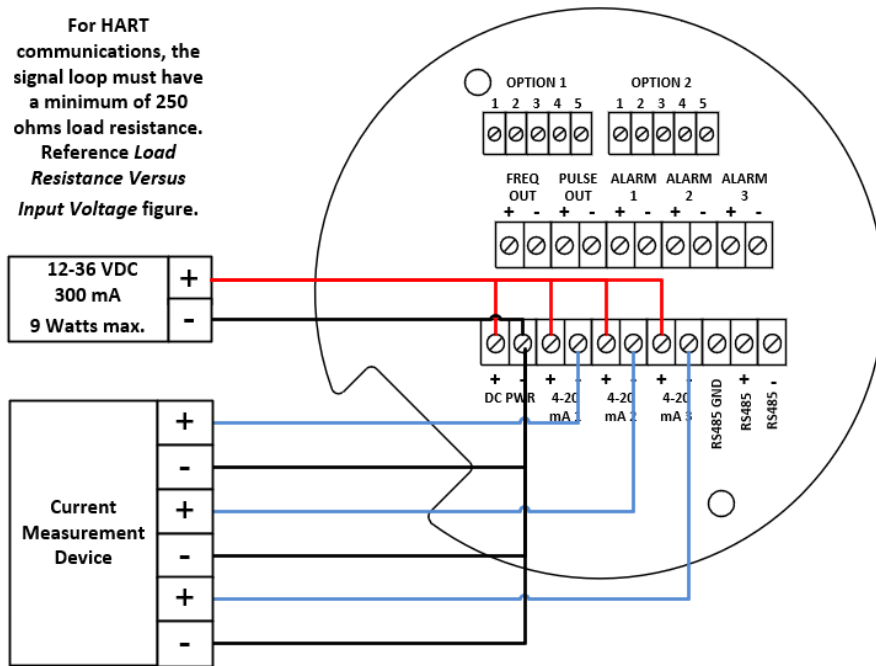

Figure 38 - Non-Isolated 4-20 mA Output Using Meter Power Supply

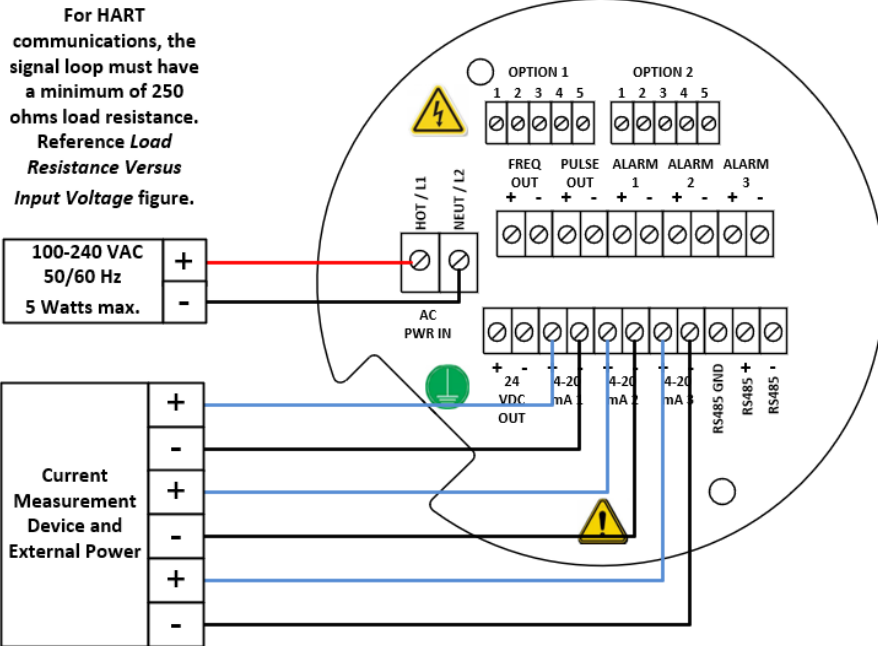

Figure 39 - Isolated 4-20 mA Output Using External Power Supply

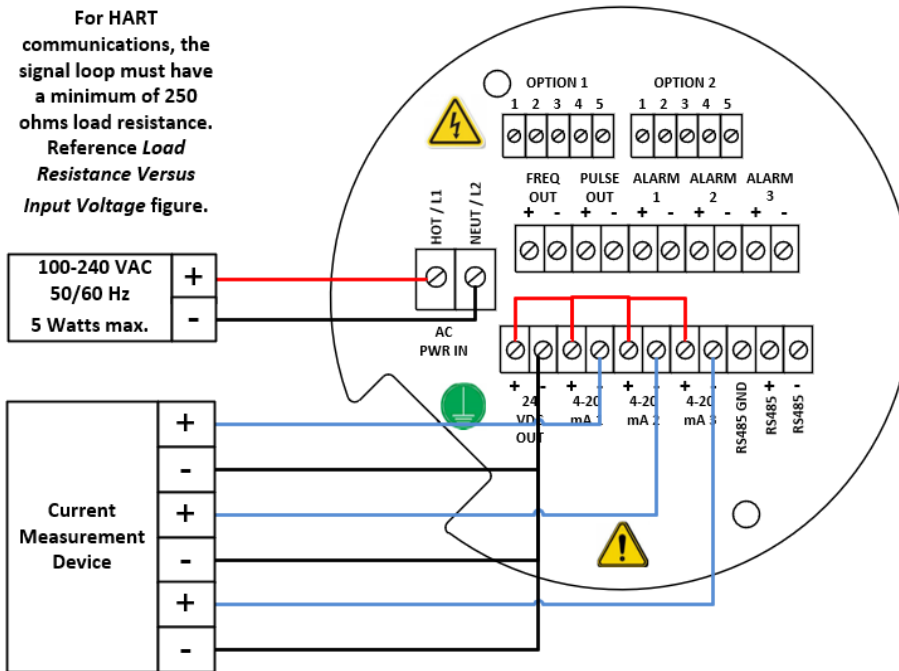

Figure 40 - Isolated 4-20 mA Output Using Meter Provided Power Supply

Pulse Output Connections

The pulse output is used for a remote counter. When the preset volume or mass (defined in the totalizer settings, see page 78) has passed the meter, the output provides a 50 millisecond square pulse.

The pulse output requires a separate 5 to 36 VDC power supply. The pulse output optical relay is a normally-open single-pole relay. The relay can conduct a current up to 40 mA. It is isolated from the meter electronics and power supply.

There are three connection options for the pulse output – the first with a separate power supply (Figures 41 and 43), the second using the flow meter power supply (Figure 42)(DC powered units only), and the third using the internal 24 VDC power supply (Figure 44)(AC powered units only). Use the first option with a separate power supply (5 to 36 VDC) if a specific voltage is needed for the pulse output. Use the second configuration if the voltage at the flow meter power supply is an acceptable driver voltage for the load connected. (Take into account that the current used by the pulse load comes from the meter’s power supply). Use the third configuration if you have an AC powered unit only. In any case, the voltage of the pulse output is the same as the voltage supplied to the circuit.

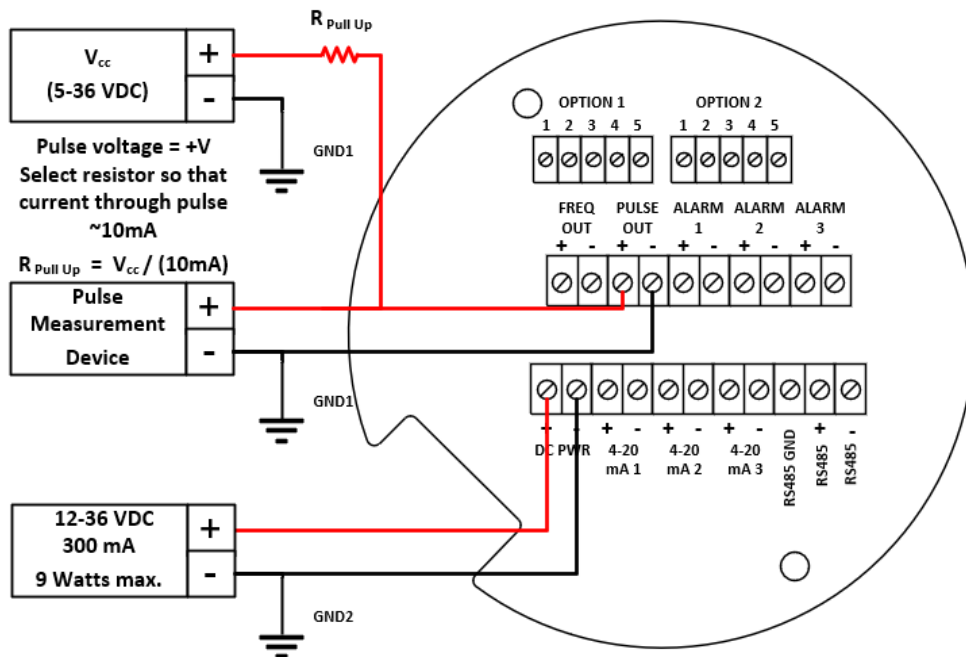

Figure 41 - Isolated Pulse Output Using External Power Supply

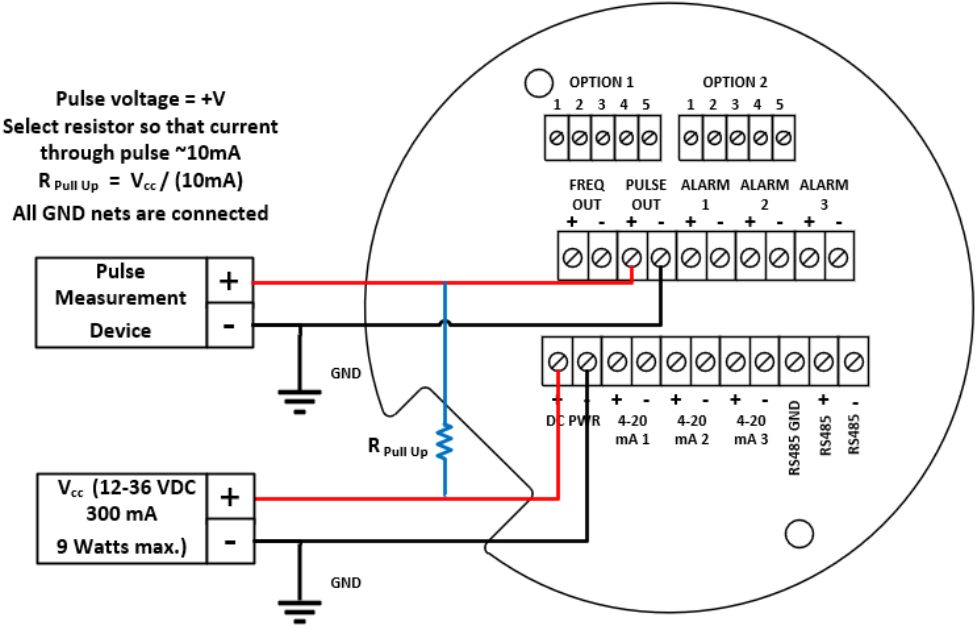

Figure 42 - Non-Isolated Pulse Output Using Input Power Supply

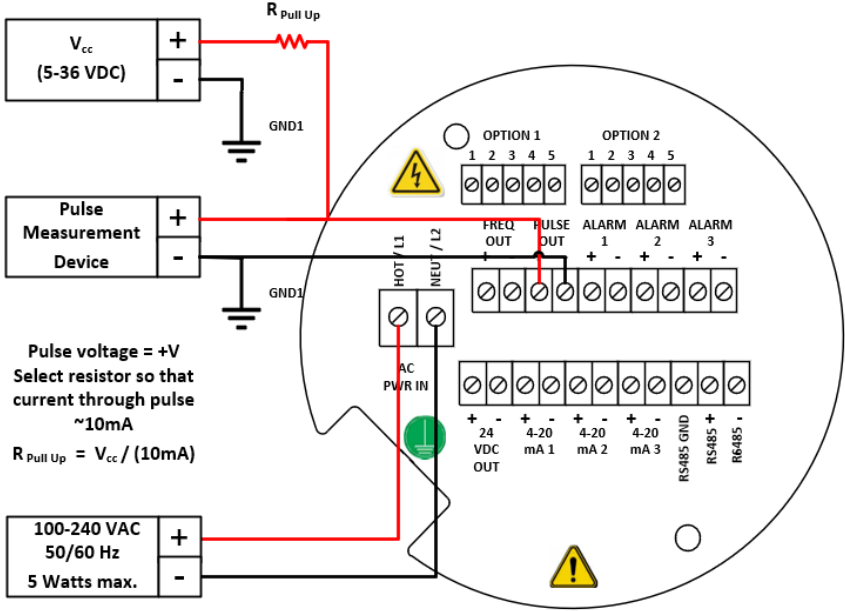

Figure 43 - Isolated Pulse Output Using External Power Supply

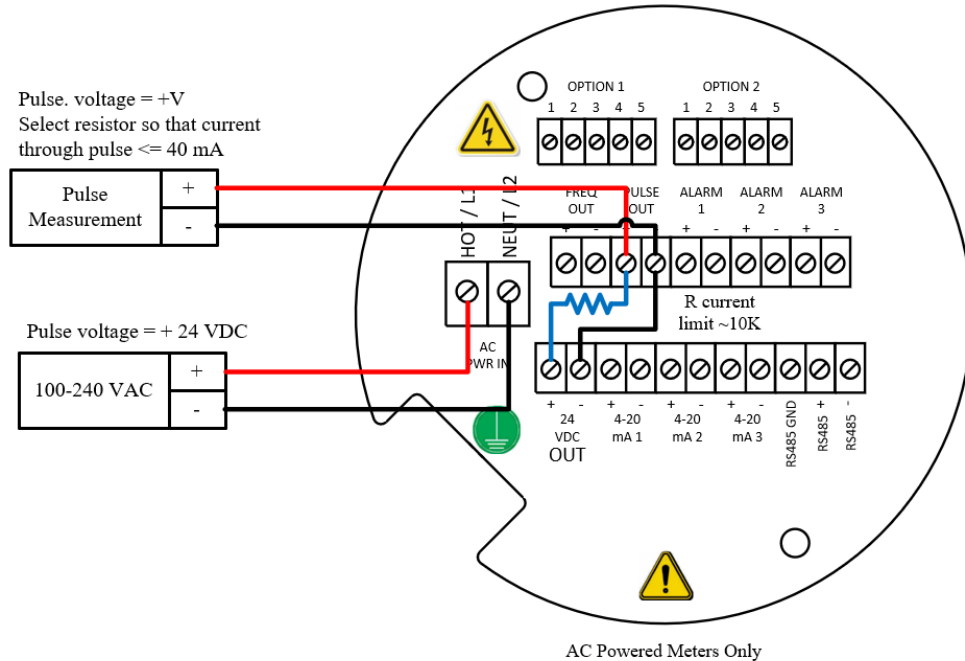

Figure 44 - Isolated Pulse Output Using Meter Provided Power Supply

Frequency Output Connections

The frequency output is used for a remote counter. It can be scaled to output a 1 to 10 kHz signal proportional to mass or volume flow, temperature, pressure, or density. Scaled frequency will need to be set in the Output Menu (see page 72).

The frequency output requires a separate 5 to 36 VDC power supply. The frequency output optical relay is a normally-open single-pole relay. The output can conduct a current up to 40 mA. It is isolated from the meter electronics and power supply.

There are three connection options for the frequency output – the first with a separate power supply (Figures 45 and 47), the second using the flow meter power supply (Figure 46)(DC powered units only), and the third using the internal 24 VDC power supply (Figure 48)(AC powered units only). Use the first option with a separate power supply (5 to 36 VDC) if a specific voltage is needed for the frequency output. Use the second configuration if the voltage at the flow meter power supply is an acceptable driver voltage for the load connected. (Take into account that the current used by the frequency load comes from the meter’s power supply). Use the third configuration if you have an AC powered unit only. In any case, the voltage of the frequency output is the same as the voltage supplied to the circuit.

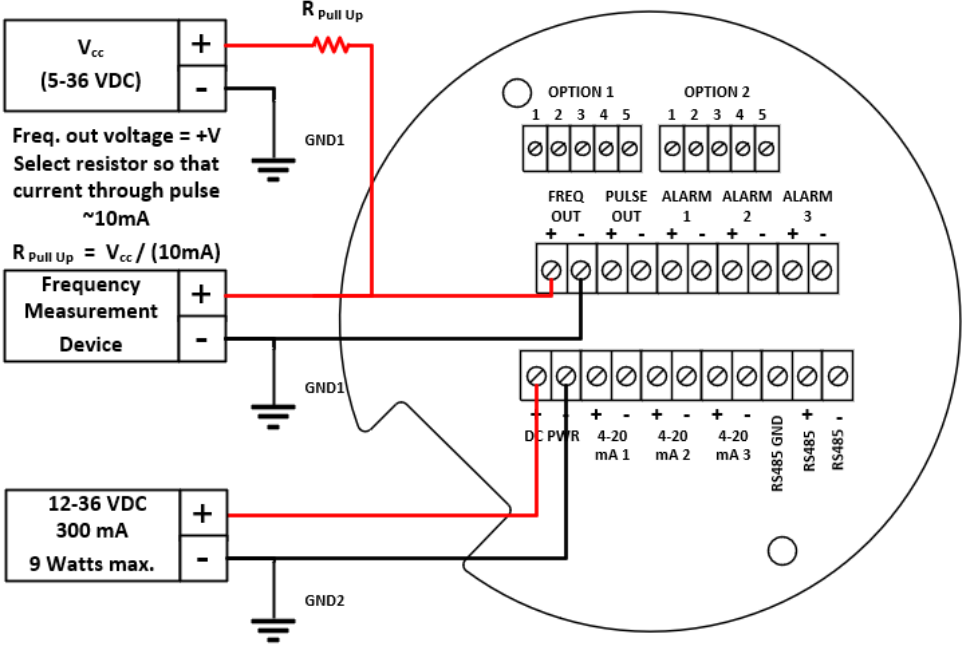

Figure 45 - Isolated Frequency Output Using External Power Supply

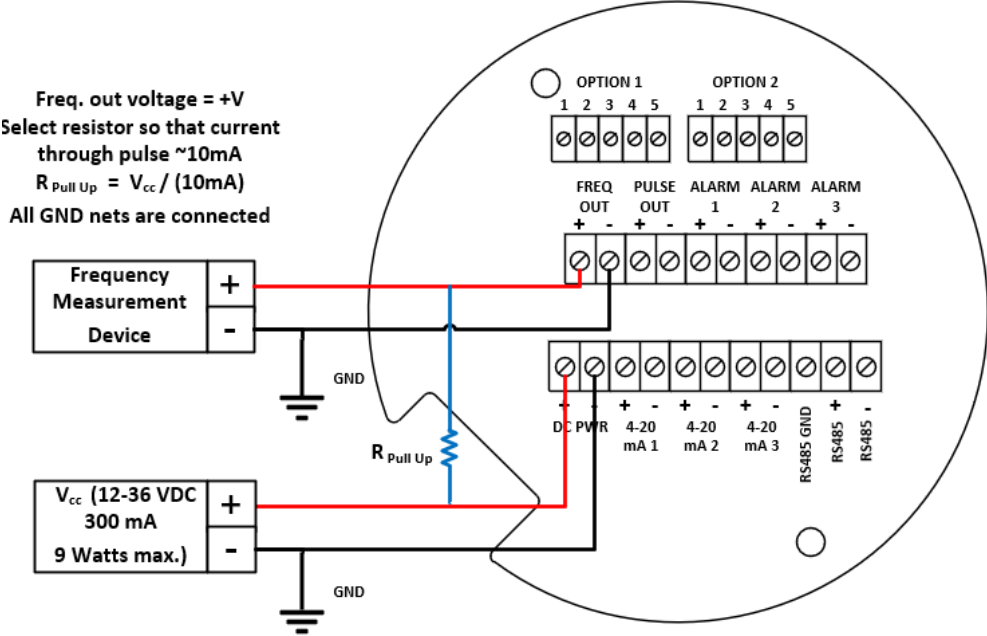

Figure 46 - Non-Isolated Frequency Output Using Meter Power Supply

The relay can conduct a current up to 40 mA. It is isolated from the meter electronics and power supply. When the alarm relay is closed, the current draw will be constant. Make sure to size R_{load} appropriately.

There are three connection options for the alarm output—the first with a separate power supply (Figures 49 and 51), the second using the flow meter power supply (Figure 50)(DC powered units only) and the third with the meter provided power supply (Figure 52)(AC powered units only). Use the first option with a separate power supply (5 to 36 VDC) if a specific voltage is needed for the alarm output. Use the second configuration if the voltage at the flow meter power supply is an acceptable driver voltage for the load connected. (Take into account that the current used by the alarm load comes from the meter’s power supply). Use the third if you have an AC powered unit only. In any case, the voltage of the alarm output is the same as the voltage supplied to the circuit.

The alarm output is used for transmitting high or low process conditions as defined in the alarm settings (see page 79).

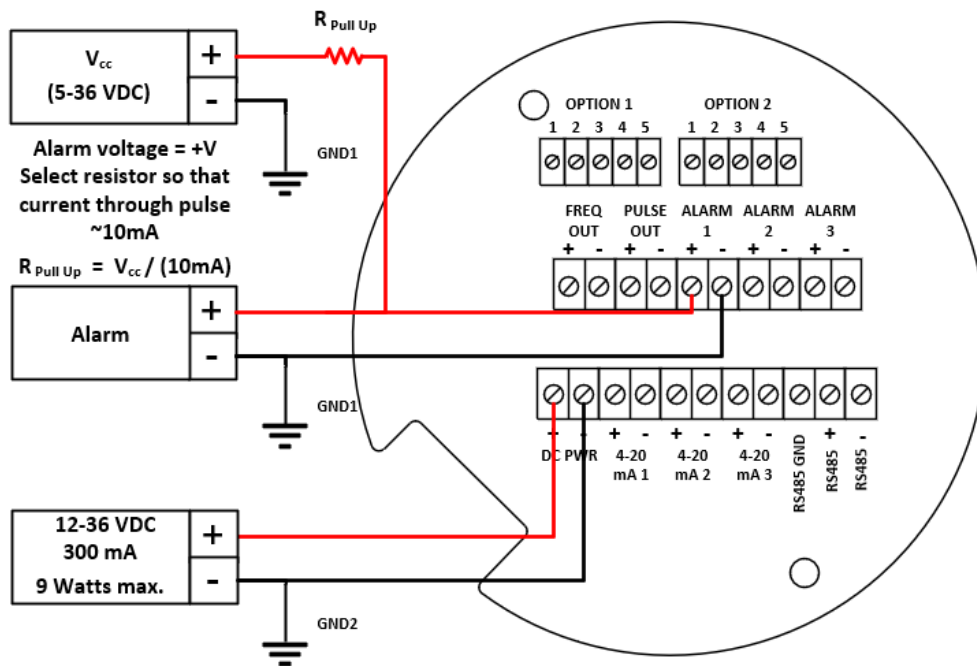

Figure 49 - Isolated Alarm Output Using External Power Supply

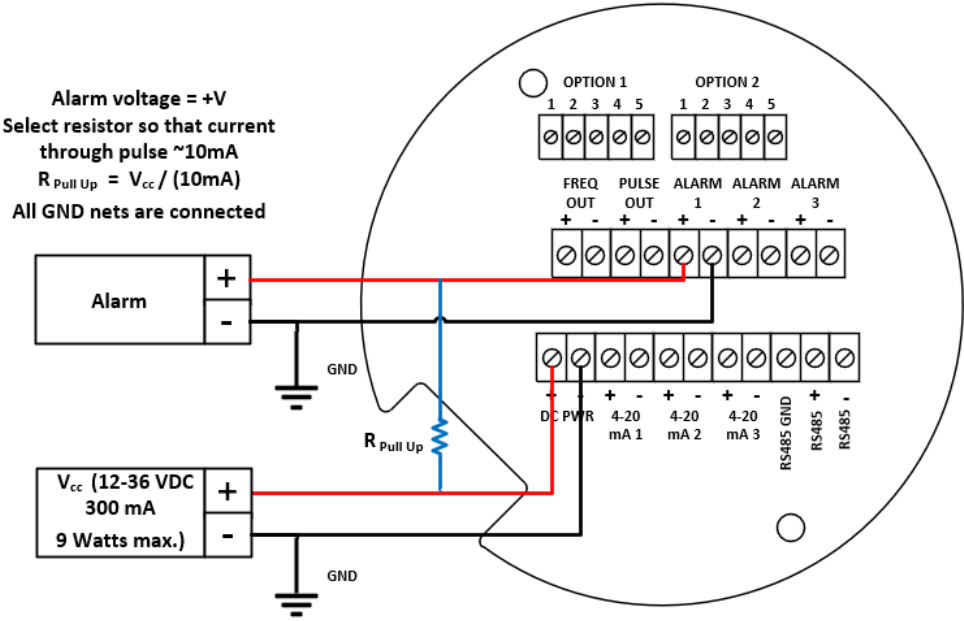

Figure 50 - Non-Isolated Alarm Output Using Meter Power Supply

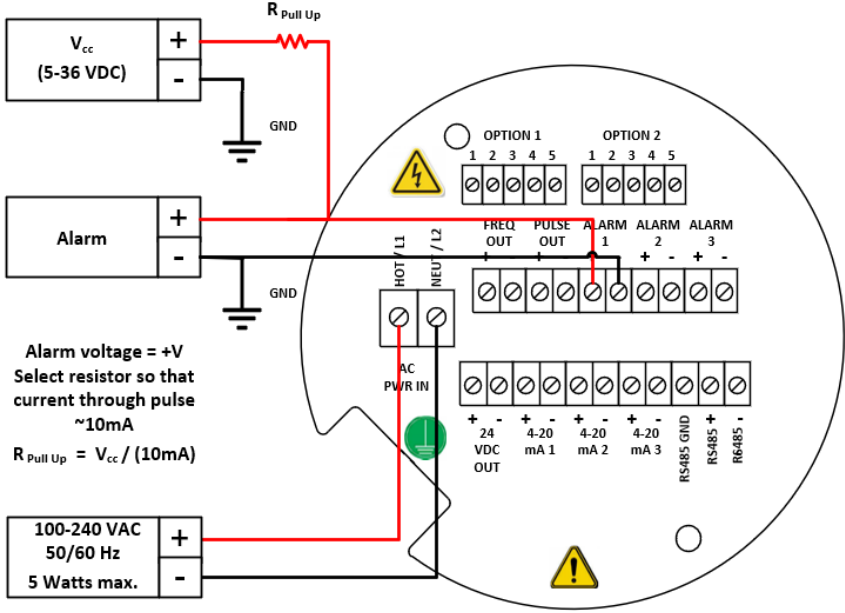

Figure 51 - Isolated Alarm Output Using External Power Supply

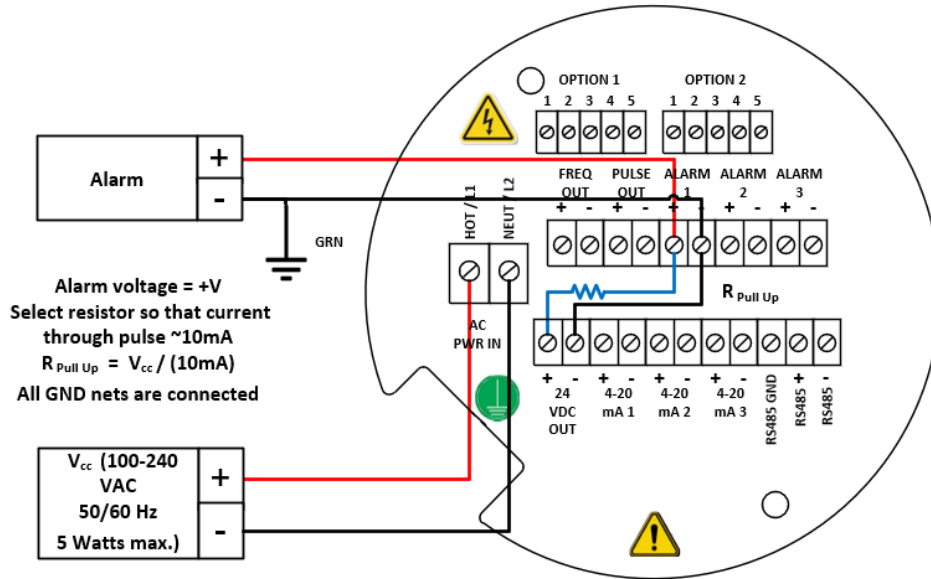

Figure 52 - Non-Isolated Alarm Output Using Meter Provided Power Supply

Remote Electronics Wiring

The remote electronics enclosure should be mounted in a convenient, easy to reach location. For hazardous location installations, make sure to observe agency requirements for installation. Allow some slack in the interface cable between the junction box and the remote electronics enclosure. To prevent damage to the wiring connections, do not put stress on the terminations at any time.

The meter is shipped with temporary strain relief glands at each end of the cable. Disconnect the cable from the meter’s terminal block inside the junction box—not at the remote electronics enclosure. Remove both glands and install appropriate conduit entry glands and conduit. The cable entry device shall be of a certified flameproof type, suitable for the conditions of use and correctly installed. The degree of protection of at least IP66 to EN 60529 is only achieved if certified cable entries are used that are suitable for the application and correctly installed. Unused apertures shall be closed with suitable blanking elements. When installation is complete, re-connect each labeled wire to the corresponding terminal position on the junction box terminal block. Make sure to connect each wire pair’s shield. Note: incorrect connection will cause the meter to malfunction.

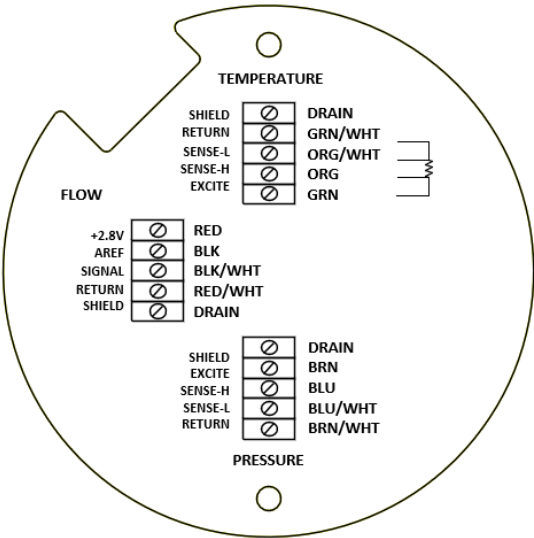

Figure 53 - High Power Flowmeter Junction Box Sensor Connections

Note: Numeric code on junction box label matches wire labels.

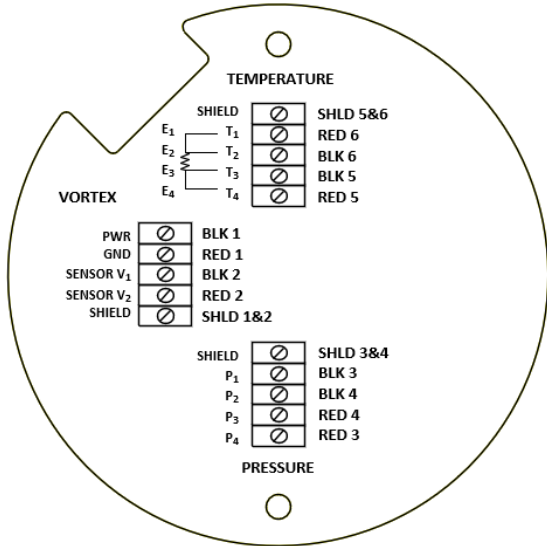

Figure 54 High Power Flowmeter Junction Box Sensor Connections (Supplied Prior to Mar. 1, 2025)

Optional Input Electronics Wiring

The meter has two optional input wiring terminals, maximum wire size is 16 AWG. These can be used to input a Remote or Second RTD input in the case of an Energy Monitoring meter, for the input of a Remote Pressure Transducer, to pass a Contact Closure or for a Remote Density measurement to name a few. In any case, the wiring diagram will be included with the meter if any of the options are specified. Otherwise, the optional terminal blocks will be left blank and nonfunctional.

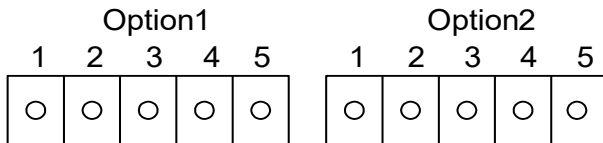

Figure 55 - Optional Terminal Blocks

Optional Energy EMS RTD Input Wiring

Loop Power

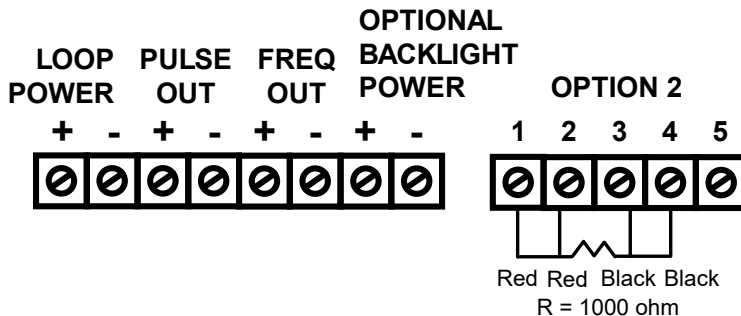

Figure 56 - Loop Power EMS RTD

*Other input options available.

High Power

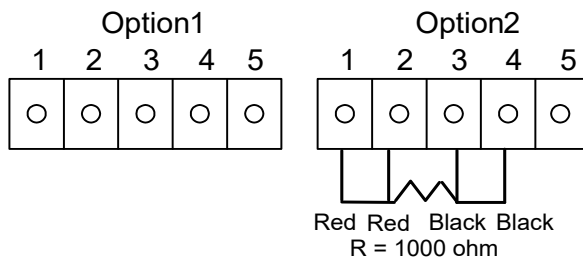

Figure 57 - High Power EMS RTD

The recommended customer supplied second RTD is a Class A 1000 ohm 4-wire platinum RTD. If a second RTD is not being used, then the factory supplied 1000 ohm resistor needs to be installed in its place.

Optional External 4-20 mA Input Wiring

The meter is set to have Option 1 used for the external input. Programming menus that pertain to the optional 4-20 mA input are located in the Hidden Diagnostics Menu in Chapter 5.

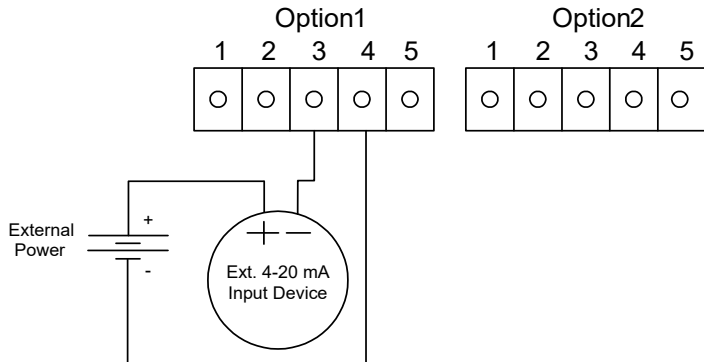

Figure 58 - External 4-20 mA Input Wiring - External Power Supply

Follow the above diagram to wire the external 4-20 mA input into the flow meter using an external power supply.

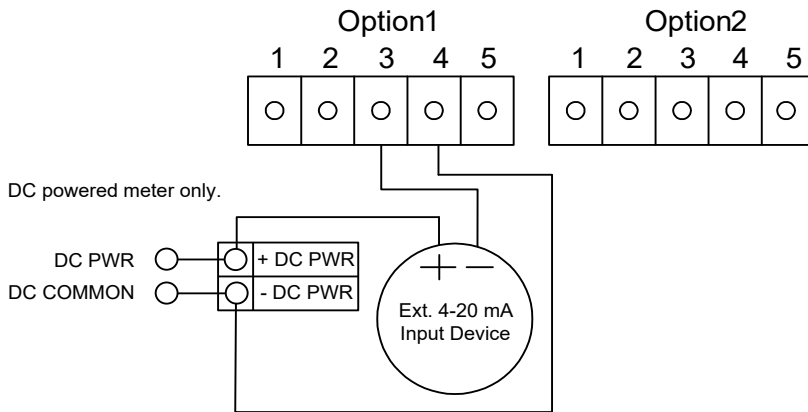

Figure 59 - External 4-20 mA Input Wiring - DC Powered Meter

Follow the above diagram to wire the external 4-20 mA input into the flow meter using power supplied to the input of a DC powered meter.

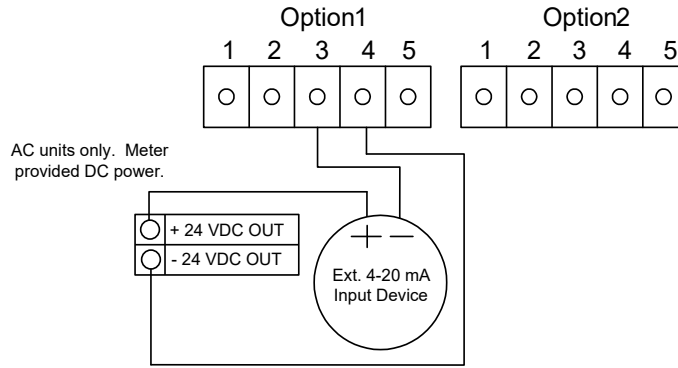

Figure 60 - External 4-20 mA Input Wiring - AC Powered Meter

Follow the above diagram to wire the external 4-20 mA input into the flow meter using power from the 24 VDC output of an AC powered meter.

Optional External 4-20 mA Input and RTD Wiring Loop Power

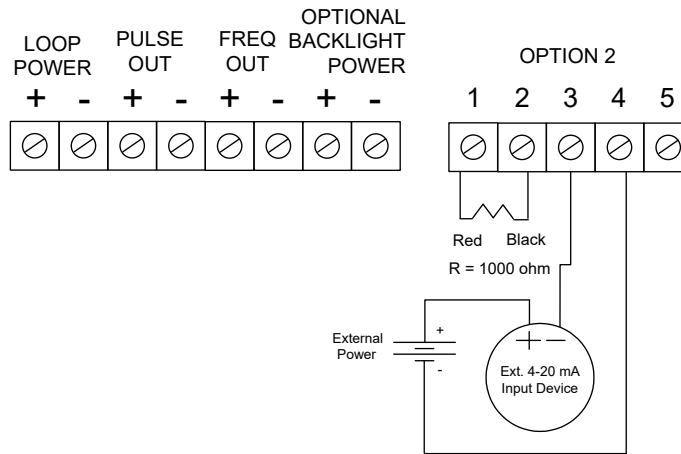

Figure 61 - External 4-20 mA Input and RTD Wiring - Loop Power High Power

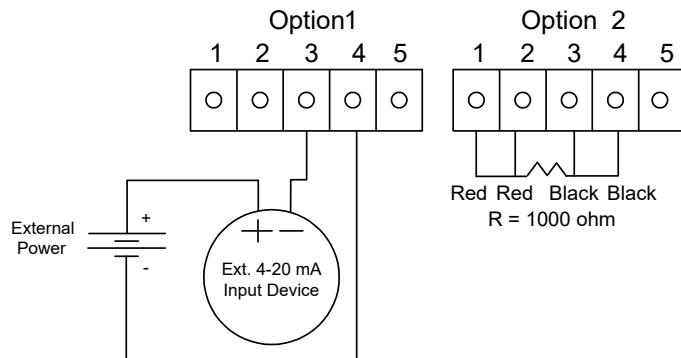

Figure 62 - External 4-20 mA Input and RTD Wiring - High Power

Optional Energy EMS External 4-20 mA Input and RTD Wiring

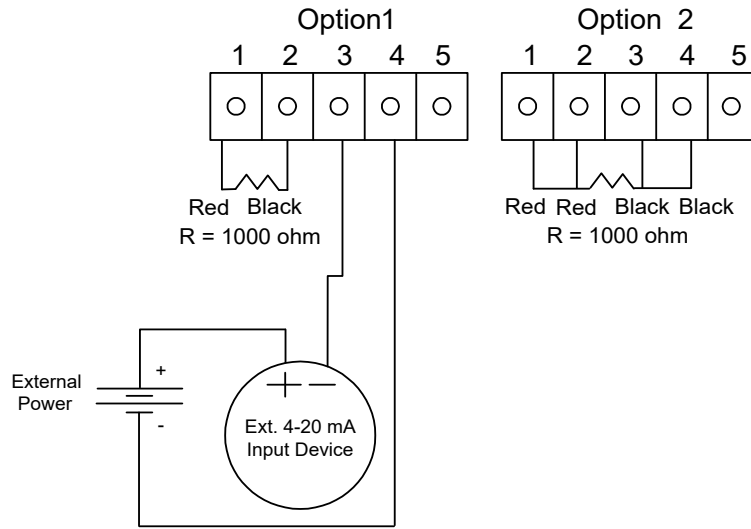

Figure 63 - Energy EMS External 4-20 mA Input and RTD Wiring - High Power

Optional External Contact Closure Input Wiring

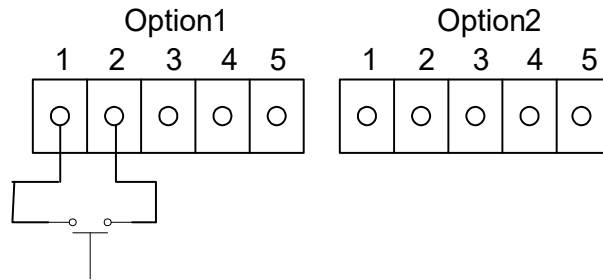

Figure 64 - Optional External Contact Closure Input Wiring

Follow the above diagram to wire an external switch input into the flow meter. The meter is configured to have Option 1 used for the external input. If the above switch is used to remotely reset the totalizer a pushbutton switch with a momentary contact closure is recommended.

Chapter 3 Operating Instructions



Warning!

Do not open covers when an explosive atmosphere may be present.

After installing the InnovaMass® Vortex Flow Meter, you are ready to begin operation. The sections in this chapter explain the display/keypad commands, meter start-up and programming. The meter is ready to operate at start up without any special programming. To enter parameters and system settings unique to your operation, see the following pages for instructions on using the setup menus.

Flow Meter Display/Keypad

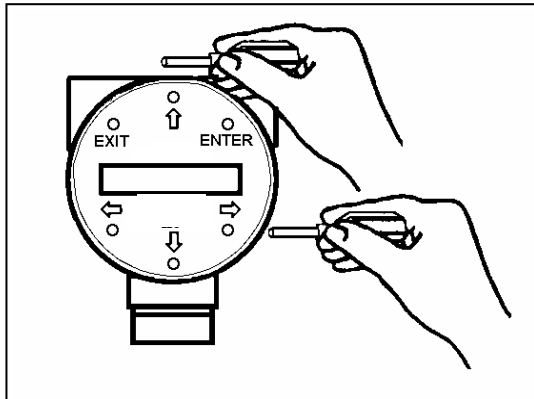

The flow meter's digital electronics allow you to set, adjust and monitor system parameters and performance. A full range of commands are available through the display/keypad. The LCD display gives 2 x 16 characters for flow monitoring and programming. The six pushbuttons can be operated with the enclosure cover removed, or the explosion-proof cover can remain in place and the keypad operated with a hand-held magnet positioned at the side of the enclosure as shown in the illustration at the left. To secure the enclosure cover use a 1/16" hex key wrench to tighten the 6-32 x 1/4 cup point socket set locking screw.

Display/Keypad
Commands

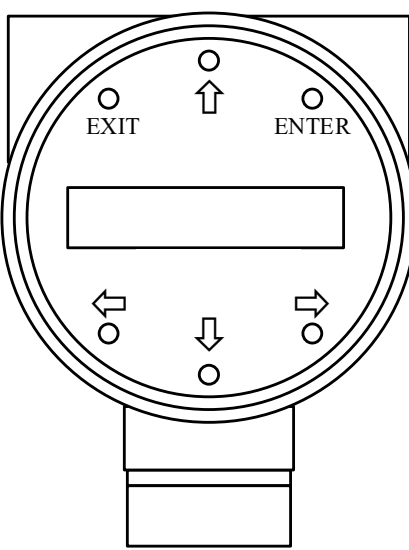

From the Run Mode, the **ENTER** key allows access to the Setup Menu (through a password screen). Within the Setup Menu, pressing **ENTER** activates the current field. To set new parameters, press the **ENTER** key until an underline cursor appears. Use the **↑ ↓ ← →** keys to select new parameters. Press **ENTER** to continue (If change is not allowed, **ENTER** has no effect). All outputs are disabled when using the Setup Menu.

The **EXIT** key is active within the Setup Menu. When using a Setup Menu, **EXIT** returns you to the Run Mode. If you are changing a parameter and make a mistake, **EXIT** allows you to start over.

The **↑ ↓ ← →** keys advance through each screen of the current menu. When changing a system parameter, all **↑ ↓ ← →** keys are available to enter new parameters.

The flow meter's digital electronics allow you to set, adjust and monitor system parameters and performance. A full range of commands are available through the display/keypad. The LCD display gives 2 x 16 characters for flow monitoring and programming. The six pushbuttons can be operated with the enclosure cover removed, or the explosion-proof cover can remain in place and the keypad operated with a hand-held magnet positioned at the side of the enclosure as shown in the illustration at the left. To secure the enclosure cover use a 1/16" hex key wrench to tighten the 6-32 x 1/4 cup point socket set locking screw.

Figure 65 - Flow Meter Display/Keypad

Display Contrast Adjustment

The flow meter display contrast is set at the factory but if the display characters appear too dark or too light proceed as follows:

1. Hold down the “Exit” button on the front panel for 5 to 10 seconds. “Setting Contrast” will appear.
2. Push the “Up” arrow to darken the display or the “Down” arrow to lighten it.
3. Push the “Enter” button to save the contrast setting.

Start-Up



Note: Starting the flow meter or pressing EXIT will always display the Run Mode screens.

To begin flow meter operation:

1. Verify the flow meter is installed and wired as described in Chapter 2.
2. Apply power to the meter. At start up, the unit runs a series of self-tests that check the RAM, ROM, EPROM and all flow sensing components. After completing the self-test sequence, the Run Mode screens appear.
3. The Run Mode displays flow information as determined by system settings. Some screens depicted on the next page may not be displayed based on these settings. Press the $\uparrow\downarrow$ arrow keys to view the Run Mode screens.
4. Press the ENTER key from any Run Mode screen to access the Setup Menus. Use the Setup Menus to configure the meter’s multi-parameter features to fit your application.

Run Mode Screens

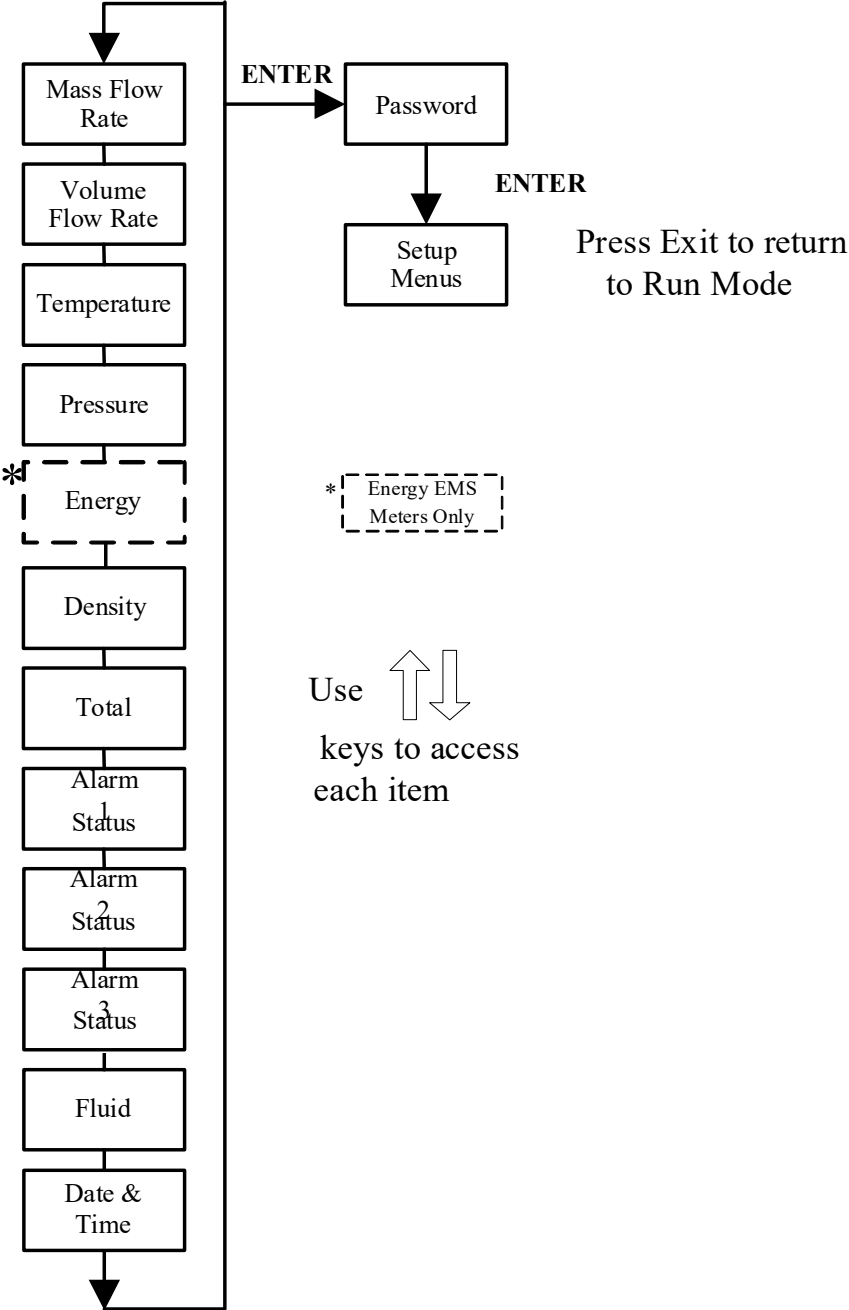

Using the Setup Menus

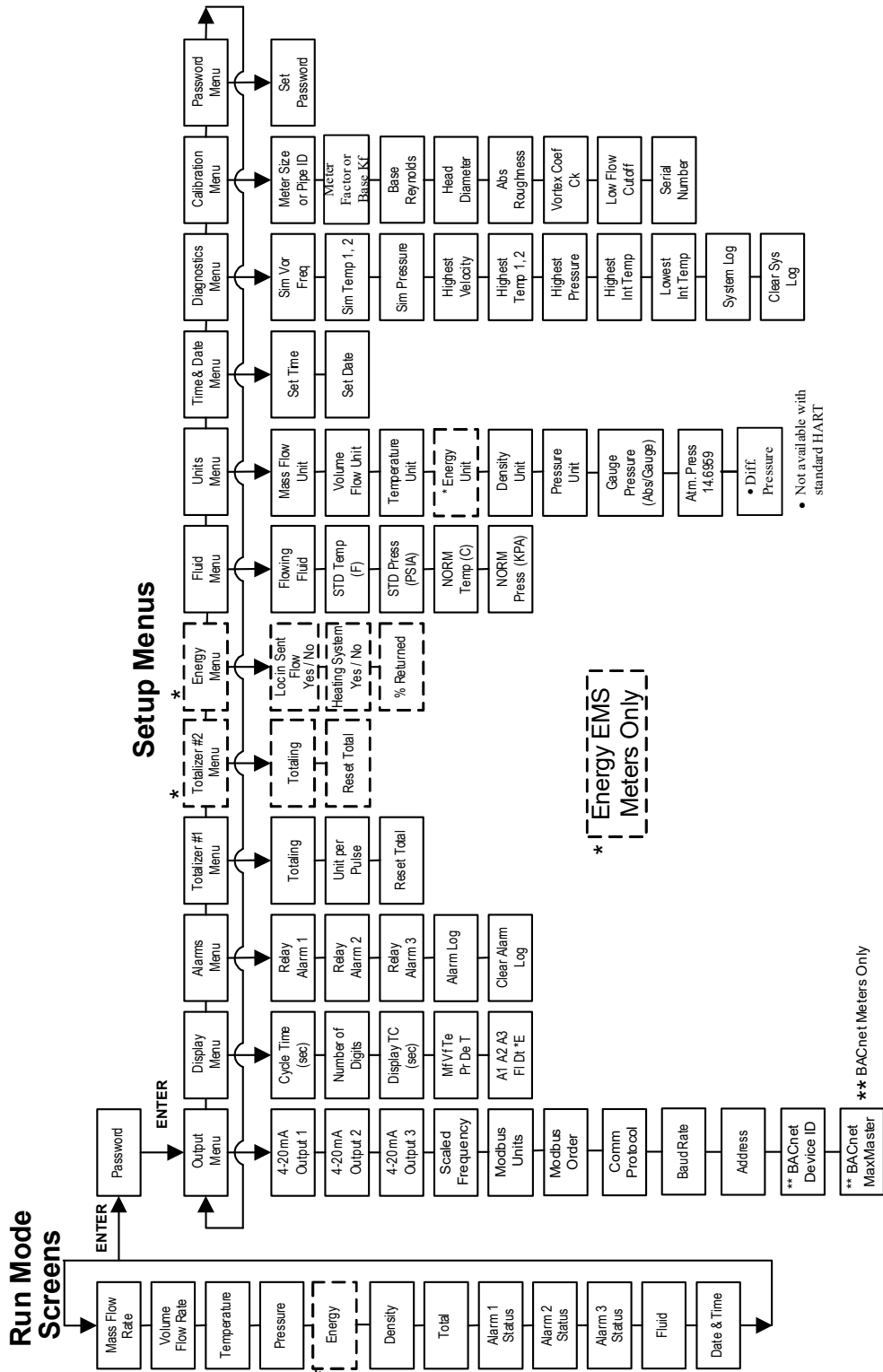

Programming the Flow Meter

1. Enter the Setup Menu by pressing the ENTER key until prompted for a password. (All outputs are disabled while using the Setup Menus.)
2. Use the $\uparrow\downarrow\leftarrow\rightarrow$ keys to select the password characters (1234 is the factory-set password). When the password is correctly displayed, press ENTER to continue.
3. Use the Setup Menus described on the following pages to customize the multi-parameter features of your InnovaMass® Flow Meter. (The entire lower display line is available for entering parameters.) Some items depicted in the graphic on the preceding page may not be displayed based on flow meter configuration settings.
4. To activate a parameter, press ENTER. Use the $\uparrow\downarrow\leftarrow\rightarrow$ keys to make selections. Press ENTER to continue. Press EXIT to save or discard changes and return to Run Mode.
5. **Program the UNITS menu first because later menus will be based on the units selected.**
6. ****NOTE: The meter will come from the factory preprogrammed for your application. ****

Output Menu

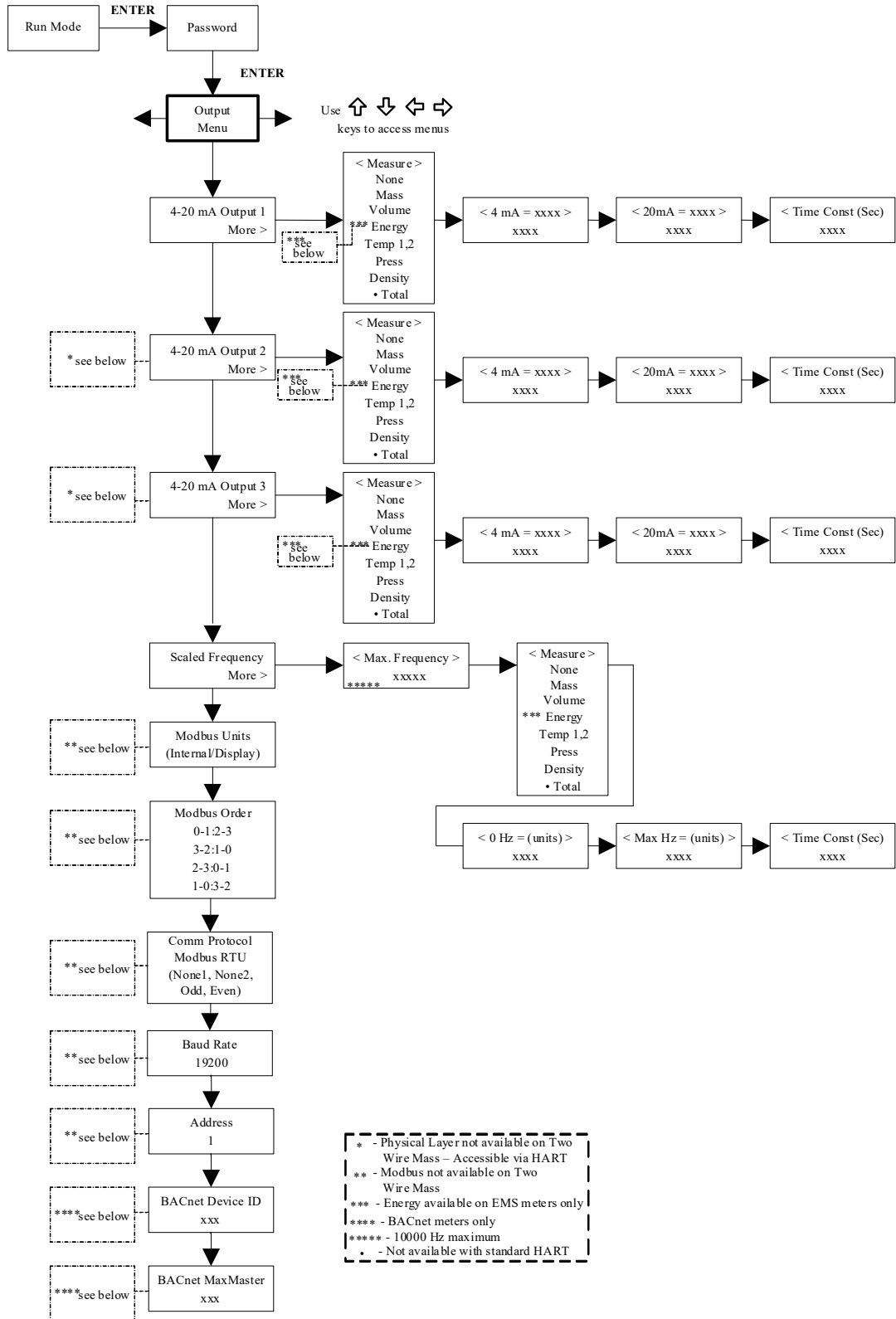

Example for Setting an Output

The following shows how to set Output 1 to measure mass flow with 4 mA = 0 lb/hr and 20 mA = 100 lb/hr with a time constant of 5 seconds. (All outputs are disabled while using the Setup Menus.)

First, set the desired units of measurement:

1. Use $\leftarrow\rightarrow$ keys to move to the Units Menu (see page 85).
2. Press \downarrow key until Mass Flow Unit appears. Press ENTER.
3. Press \downarrow key until lb appears in the numerator. Press \rightarrow key to move the underline cursor to the denominator. Press the \downarrow key until hr appears in the denominator. Press ENTER to select.
4. Press \uparrow key until Units Menu appears.
5. Second, set the analog output:
6. Use $\leftarrow\rightarrow$ keys to move to the Output Menu.
7. Press the \downarrow key until 4-20 mA Output 1 appears.
8. Press \rightarrow key to access Measure selections. Press ENTER and press the \boxtimes key to select Mass. Press ENTER.
9. Press \rightarrow key to set the 4 mA point in the units you have selected for mass of lb/hr. Press ENTER and use $\uparrow\downarrow\leftarrow\rightarrow$ keys to set 0 or 0.0. Press ENTER.
10. Press \rightarrow key to set the 20 mA point. Press ENTER and use $\uparrow\downarrow\leftarrow\rightarrow$ keys to set 100 or 100.0. Press ENTER.
11. Press \rightarrow key to select the Time Constant. Press ENTER and use $\uparrow\downarrow\leftarrow\rightarrow$ keys to select 5. Press ENTER.
12. Press the EXIT key and answer YES to permanently save your changes.

Example for Calculating Output Current

Assumer Output 1 is scaled as above for mass flow with 4 mA = 0 lb/hr and 20 mA = 100 lb/hr.

Output 1 current = $((\text{Flow rate} / 100) \times 16 \text{ mA}) + 4 \text{ mA}$

Example for Setting a Scaled Frequency

The following shows how to set Scaled Frequency to measure temperature with Max. Frequency = 5000 Hz, 0 Hz = 0 °F, and MaxHz = 300°F with a time constant of 5 seconds. (All outputs are disabled while using the Setup Menus.)

First, set the desired units of measurement:

1. Use $\leftarrow\rightarrow$ keys to move to the Units Menu (see page 83).
 2. Press \downarrow key until Mass Flow Unit appears. Press ENTER.
 3. Press \downarrow key until lb appears in the numerator. Press \rightarrow key to move the underline cursor to the denominator. Press the \downarrow key until hr appears in the denominator. Press ENTER to select.
 4. Press \uparrow key until Units Menu appears.
5. Second, set the frequency output:
6. Use $\leftarrow\rightarrow$ keys to move to the Output Menu.
 7. Press the \downarrow key until Scaled Frequency appears.
 8. Press \rightarrow key to access Maximum Frequency selections. Press ENTER and use the $\uparrow\downarrow\leftarrow\rightarrow$ keys to select frequency. Press ENTER.
 9. Press \rightarrow key to access Measure selections. Press ENTER and press the \downarrow key to select Temp. Press ENTER.
 10. Press \rightarrow key to set the 0 Hz point in the units you have selected for temperature of °F. Press ENTER and use $\uparrow\downarrow\leftarrow\rightarrow$ keys to set 0 or 0.0. Press ENTER.
 11. Press \rightarrow key to set the Max. Hz point. Press ENTER and use $\uparrow\downarrow\leftarrow\rightarrow$ keys to set 300 or 300.0. Press ENTER.
 12. Press \rightarrow key to select the Time Constant. Press ENTER and use $\uparrow\downarrow\leftarrow\rightarrow$ keys to select 5. Press ENTER.
 13. Press the EXIT key and answer YES to permanently save your changes.

Display Menu

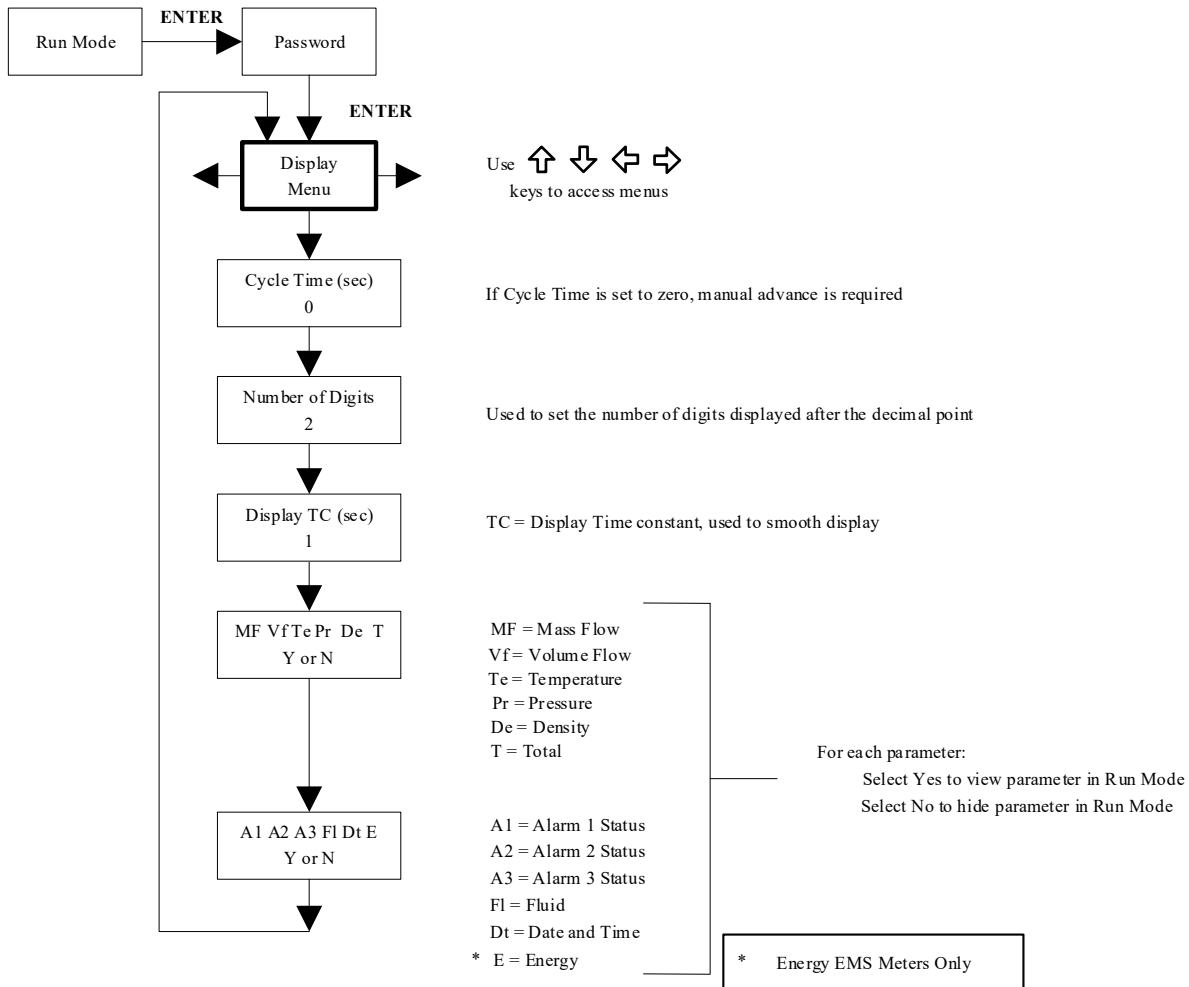

Use the Display Menu to set the cycle time for automatic screen sequencing used in the Run Mode, change the precision of displayed values, smooth the values or enable or disable each item displayed in the Run Mode screens.

Example for Changing a Run Mode Display Item

The following shows how to remove the temperature screen from the Run Mode screens. Note: all outputs are disabled while using the Setup Menus.

1. Use ← → keys to move to the Display Menu.
2. Press ↓ key until Mf Vf Pr Te De T appears.
3. Press ENTER to select. Press ⇐ key until the cursor is positioned below Te.
4. Press ↓ key until N appears. Press ENTER to select.
5. Press EXIT and then ENTER to save changes and return to the Run Mode.

Alarms Menu

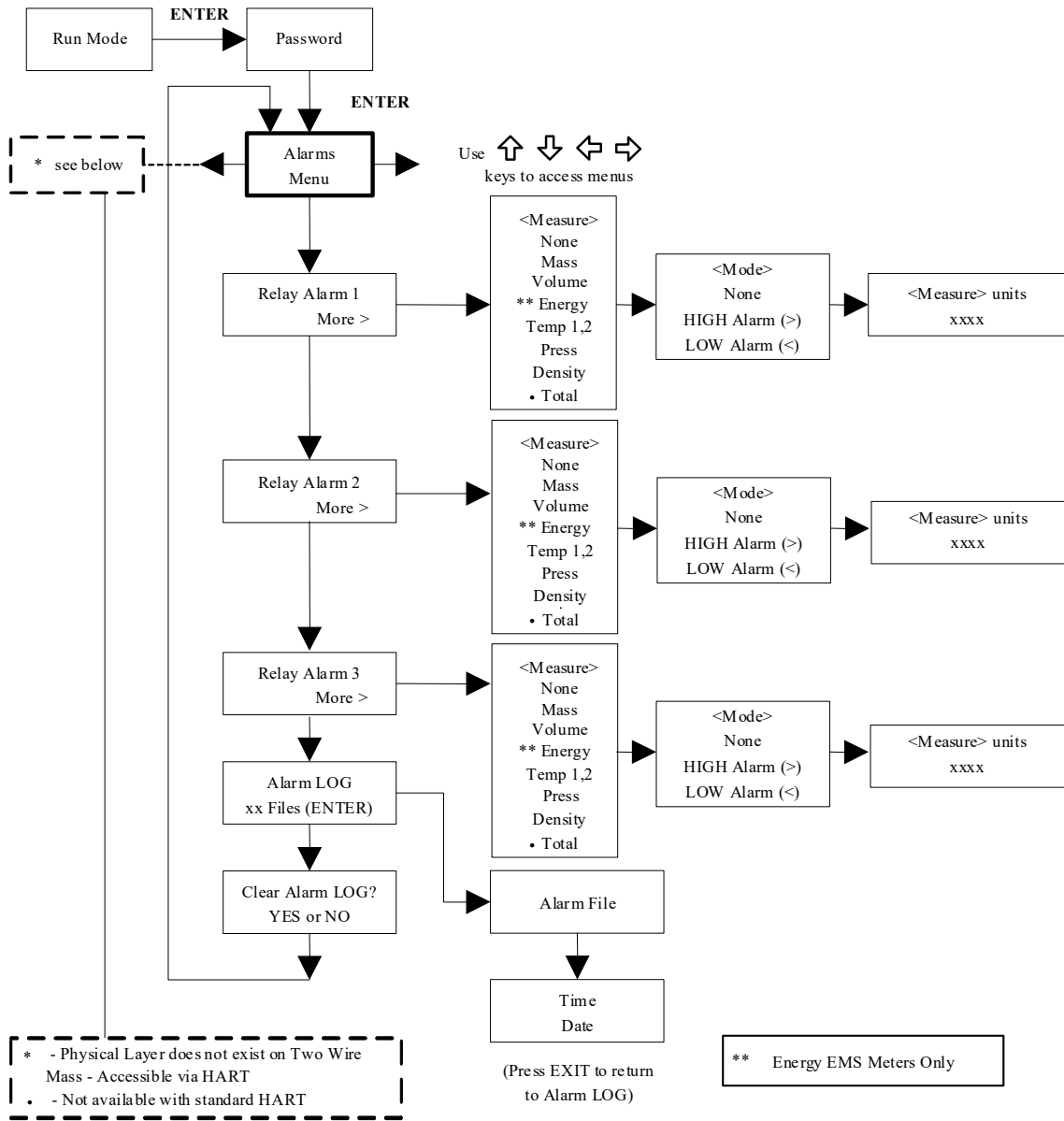

Example for Setting an Alarm

The following shows how to set Relay Alarm 1 to activate if the mass flow rate is greater than 100 lb/hr. You can check the alarm configuration in the Run Mode by pressing the $\uparrow\downarrow$ keys until Alarm [1] appears. The lower line displays the mass flow rate at which the alarm activates. Note: all outputs are disabled while using the Setup Menus.

First, set the desired units of measurement:

1. Use $\leftarrow\rightarrow$ keys to move to the Units Menu (see to page 85).
2. Press \downarrow key until Mass Flow Unit appears. Press ENTER.
3. Press \downarrow key until lb appears in the numerator. Press \rightarrow key to move the underline cursor to the denominator. Press the \downarrow key until hr appears in the denominator. Press ENTER to select.
4. Press \uparrow key until Units Menu appears.

Second, set the alarm:

1. Use $\leftarrow\rightarrow$ keys to move to the Alarms Menu.
2. Press the \downarrow key until Relay Alarm 1 appears.
3. Press \rightarrow key to access Measure selections. Press ENTER and use the \downarrow key to select Mass. Press ENTER.
4. Press \rightarrow key to select the alarm Mode. Press ENTER and use \downarrow key to select HIGH Alarm. Press ENTER.
5. Press \rightarrow key to select the value that must be exceeded before the alarm activates. Press ENTER and use $\uparrow\downarrow\leftarrow\rightarrow$ keys to set 100 or 100.0. Press ENTER.
6. Press the EXIT key to save your changes. (Alarm changes are always permanently saved.)
(Up to three relay alarm outputs are available depending on meter configuration.)

Totalizer #1 Menu

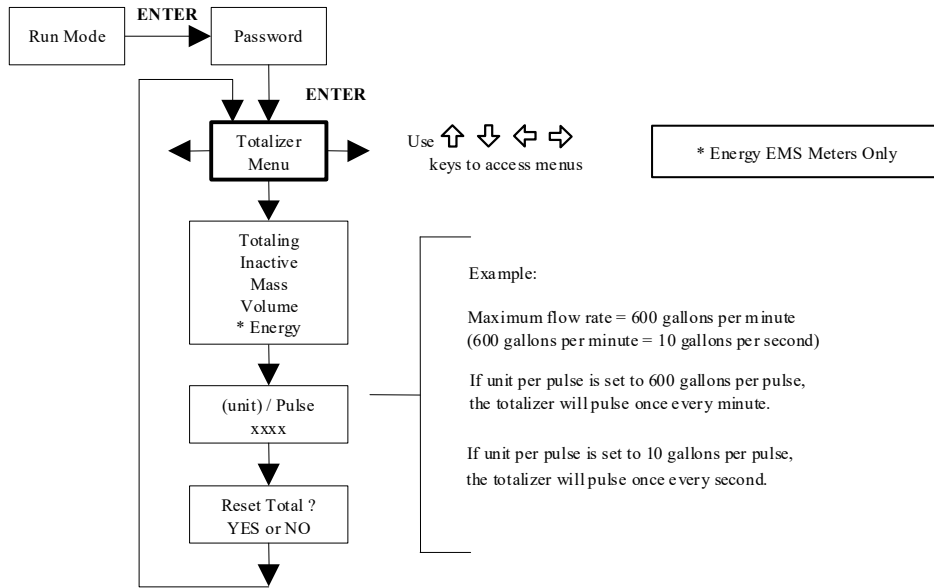

Use the Totalizer Menu to configure and monitor the totalizer. The totalizer maximum count is 999,999,999 at which point it will roll over to 0. The totalizer output is a 50 millisecond (.05 second) positive pulse (relay closed for 50 milliseconds). The totalizer cannot operate faster than one pulse every 100 millisecond (.1 second). A good rule to follow is to set the unit per pulse value equal to the maximum flow in the same units per second. This will limit the pulse to no faster than one pulse every second.

Example for Setting the Totalizer

The following shows how to set the totalizer to track mass flow in kg/sec (All outputs are disabled while using the Setup Menus).

First, set the desired units of measurement:

1. Use $\leftarrow\rightarrow$ keys to move to the Units Menu (see to page 85).
2. Press \downarrow key until Mass Flow Unit appears. Press ENTER.
3. Press \downarrow key until kg appears in the numerator. Press \rightarrow key to move the underline cursor to the denominator. Press the \downarrow key until sec appears in the denominator. Press ENTER to select.
4. Press \uparrow key until Units Menu appears.

Second, set the pulse output:

1. Use $\leftarrow\rightarrow$ keys to move to the Totalizer Menu.
2. Press the \downarrow key until Totaling appears.
3. Press ENTER and press the \downarrow key to select Mass. Press ENTER.
4. Press \downarrow key to set the pulse output in the units you have selected for mass flow of kg/sec. Press ENTER and use $\uparrow\downarrow\leftarrow\rightarrow$ keys to set the pulse value equal to the maximum flow in the same units per second. Press ENTER.
5. To reset the totalizer, press \downarrow key until Reset Total? appears. Press ENTER and the \square key to reset the totalizer if desired. Press ENTER.
6. Press the EXIT key and answer YES to permanently save your changes.

Totalizer #2 Menu

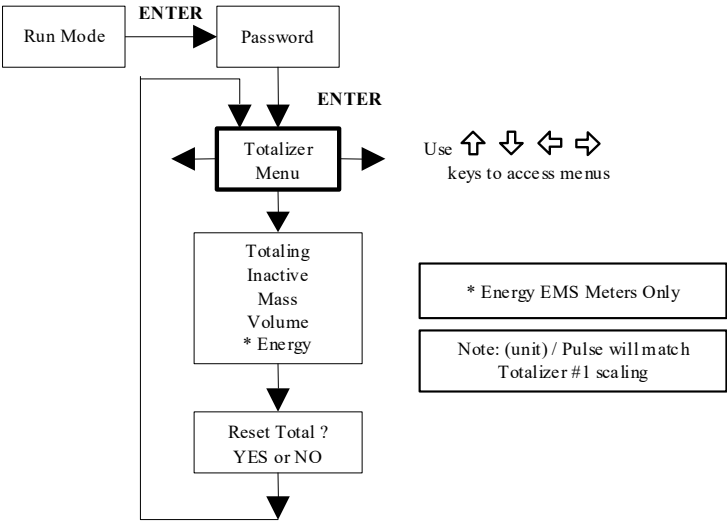

Use the Totalizer #2 to Monitor Flow or Energy. The totalizer maximum count is 999,999,999 at which point it will roll over to 0. Note that Totalizer #2 does not operate a relay, it is for monitoring only.

Energy Menu (For EMS Energy Meters Only)

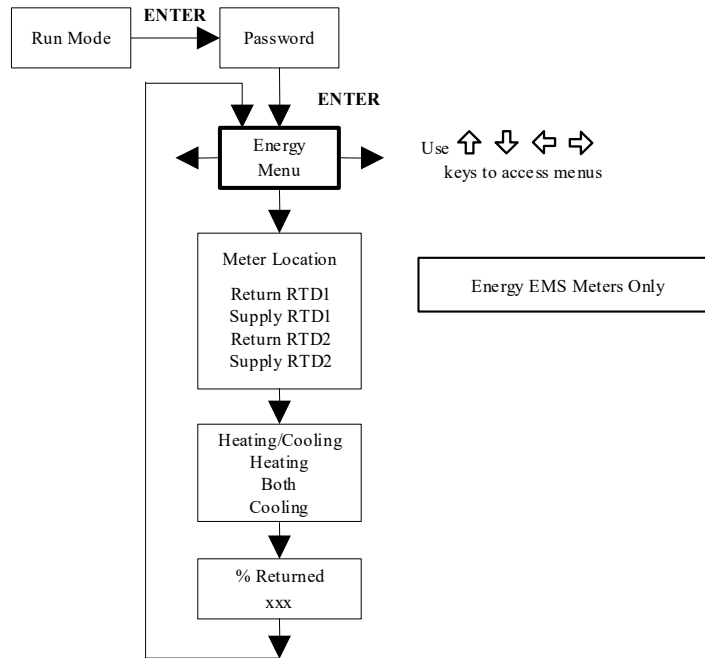

Configuration:

There are several possibilities regarding the measurement of water or steam energy given the location of the meter and the use of a second RTD. The table below summarizes the possibilities:

Fluid	Meter Location	Second RTD	Measurement
Water	“Sent” Flow Line	“Return” Flow Line	Change in Energy
Water	“Return” Flow Line	“Sent” Flow Line	Change in Energy
Water	“Sent” Flow Line	None	Outgoing Energy
Steam	“Sent” Flow Line	“Return” Flow Line (condensate)	Change in Energy
Steam	“Sent” Flow Line	None	Outgoing Energy

As above, you must properly configure the meter in the Energy Menu.

1. Loc in Sent Flow? Select Yes or No based on where the meter is located. Refer to the above table
2. Heating System? Select Yes for a hot water system used for heating. Select No for a chilled water system used for cooling. Always select Yes for a steam system.
3. % Returned. Select a number between 0% and 100%. Estimate the amount of water that returns. It is usually 100%, or can be less than 100% if historical data shows the amount of makeup water used. If a second RTD is not used, set to 0%. When 0% is selected, the energy calculation represents the outgoing energy only (no return energy is subtracted). **NOTE: the meter ships from the factory assuming 0% return and has a 1000 ohm resistor installed in the RTD #2 wiring location. This needs to be removed if the meter is to be used in a manner other than with 0% return and with the customer supplied RTD in its place.**

Fluid Menu

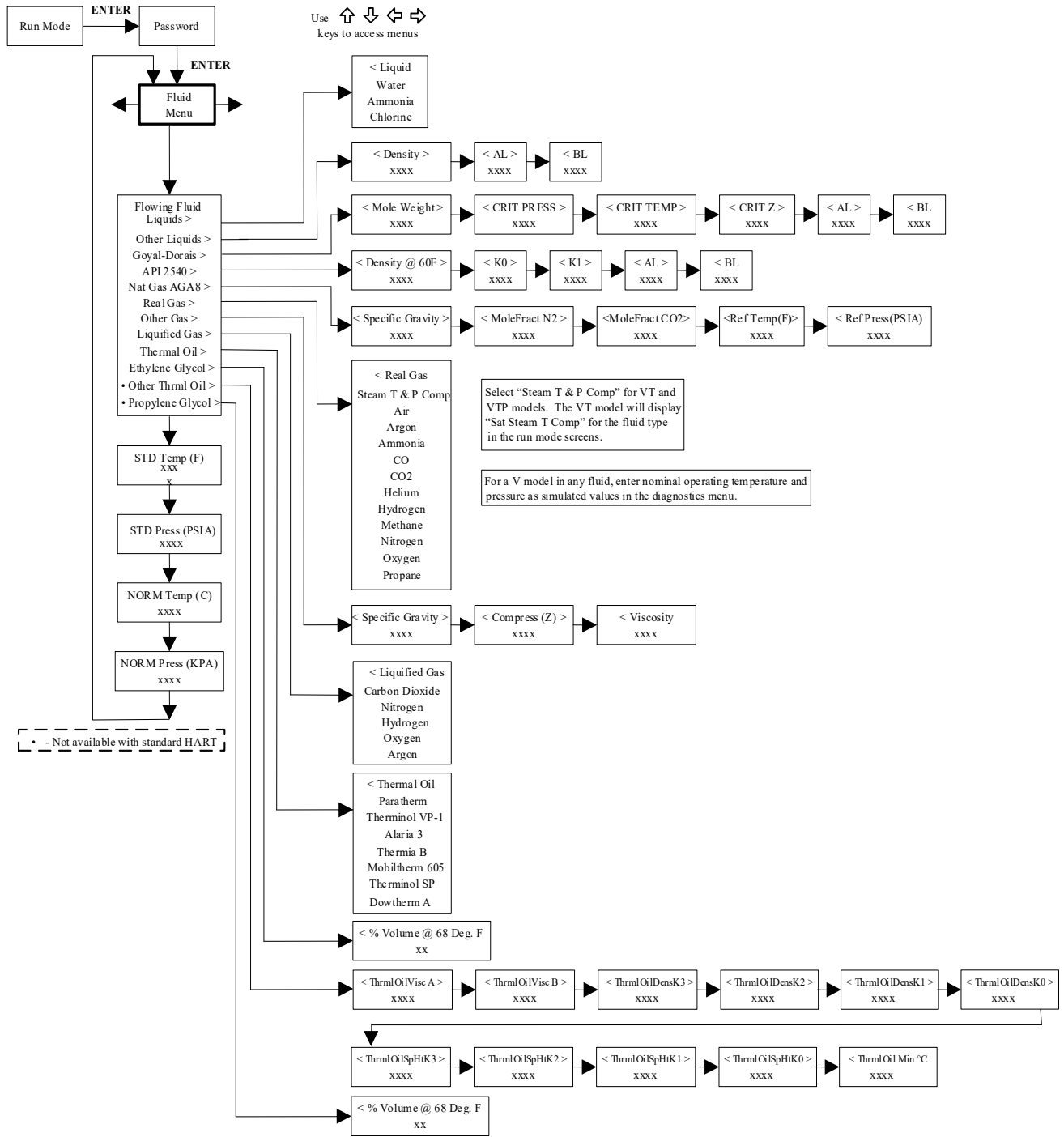

Use the Fluid Menu to configure the flow meter for use with common gases, liquids and steam. Your flow meter is pre-programmed at the factory for your application's process fluid.

Reference Richard W. Miller, *Flow Measurement Engineering Handbook (Third Edition, 1996)*, page 2-75 for definition and use of the Goyal-Doraiswamy equation and page 2-76 for the definition and use of the API 2540 equation. Also, see Appendix C for Fluid Calculation equations.

The units of measurement used in the Fluid Menu are preset and are as follows:

Mole Weight = $\text{lb}_m/(\text{lb}_m \cdot \text{mol})$, CRIT PRESS = psia, CRIT TEMP = °R, Density = lb_m/ft^3 and Viscosity = cP (centipoise).

Units Menu

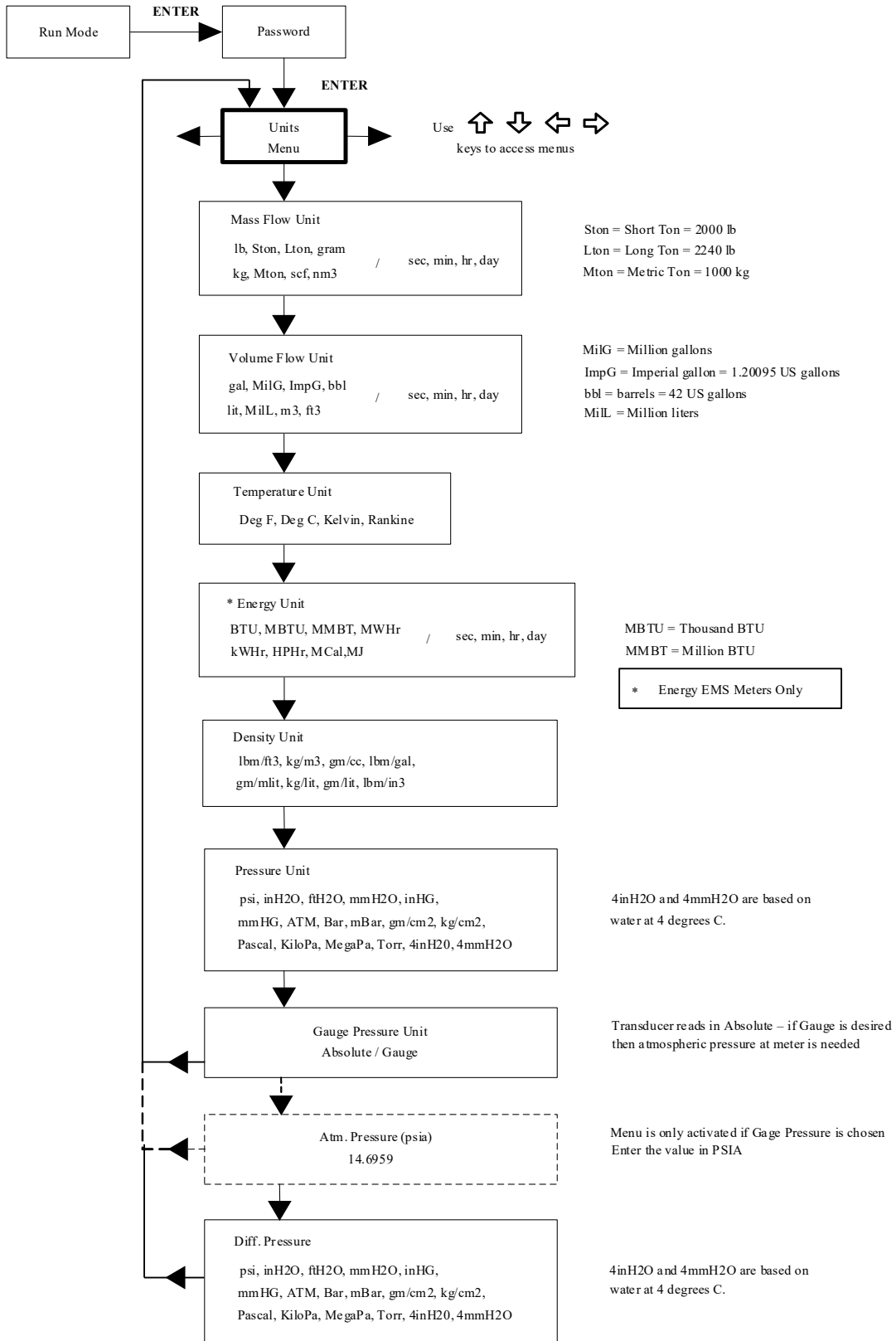

Use the Units Menu to configure the flow meter with the desired units of measurement. (These are global settings and determine what appears on all screens.)

Time & Date Menu

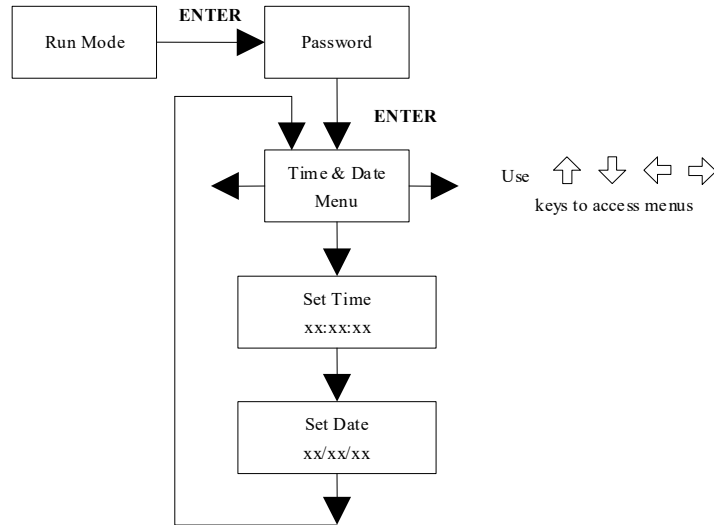

Use the Time and Date Menu to enter the correct time and date into the flow meter’s memory. The parameters are used in the Run Mode and the alarm and system log files.

Note: Time is displayed in AM/PM format, but military format is used to set the time. For example, 1:00 PM is entered as 13:00:00 in the Set Time menu.

Example for Setting the Time

How to set the time to 12:00:00. You can check the time in the Run Mode by pressing the keys until the Time & Date screen appears. Note: all outputs are disabled while using the Setup Menus.

1. Use keys to move to the Time and Date Menu.
2. Press key until Set Time appears. Press ENTER.
3. Press key until 1 appears. Press key to move the underline cursor to the next digit. Press the key until 2 appears. Continue sequence until all desired parameters are entered. Press ENTER to return to the Time and Date Menu.
4. Press EXIT to return to the Run Mode.

Diagnostics Menu

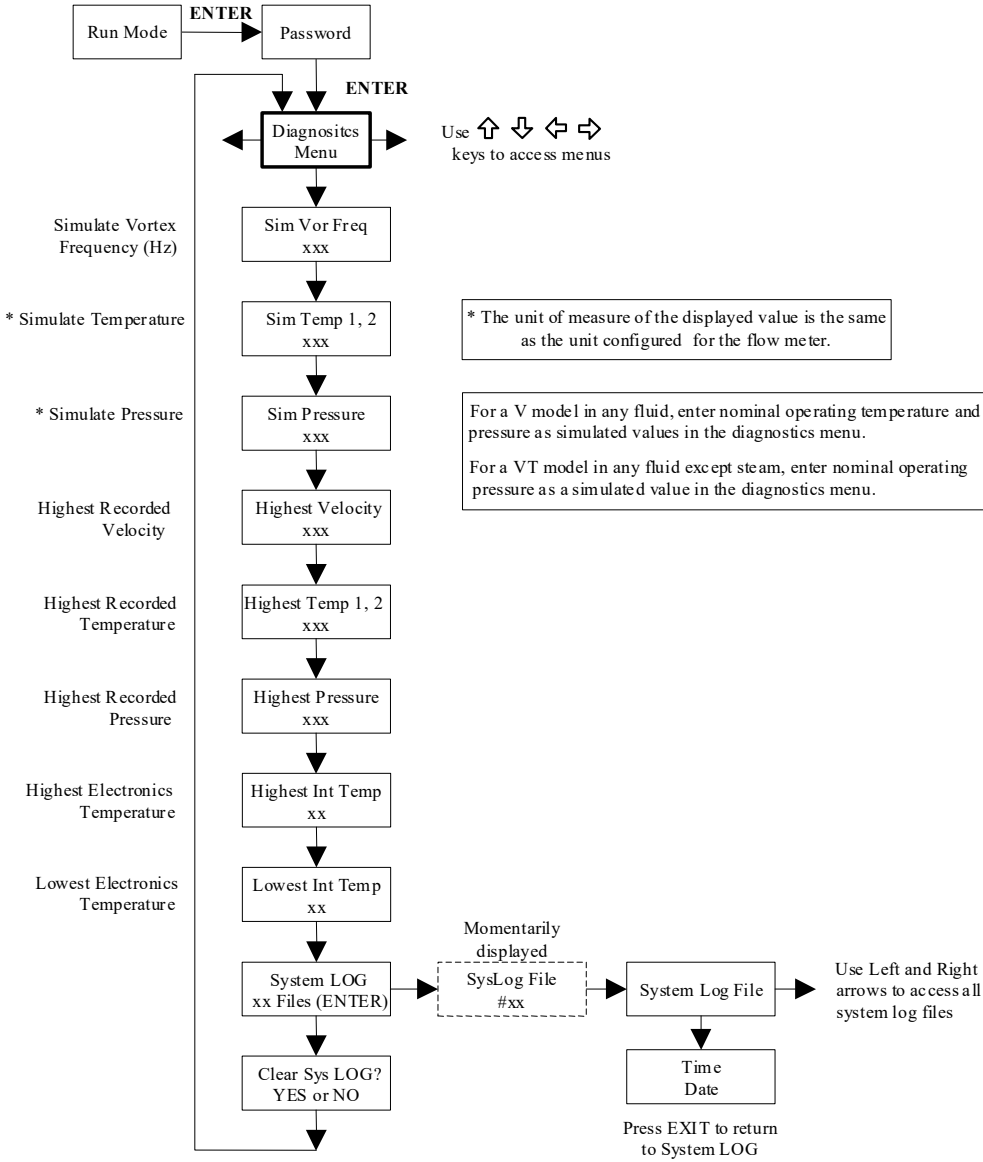

Use the Diagnostics Menu to simulate operation and review the system files. The system log files contain time/date stamped messages including: power on, power off, programming time outs, parameter faults, incorrect password entry and other various information relative to system operation and programming.

The simulated inputs are for testing the meter to verify that the programming is correct. They are also used to enter nominal operating temperature and pressure for the V only model. Simulated vortex frequency allows you to enter any value for the sensor input in Hz. The meter will calculate a flow rate based on the corresponding value and update all analog outputs (**the totalizer display and output is not affected by a simulated frequency**). The simulated pressure and temperature settings work the same way. The meter will output these new values and will use them to calculate a new density for mass flow measurement.

**NOTE**

When your diagnostic work is complete, make sure to return the values to zero to allow the electronics to use the actual transducer values. For the V only model keep the temperature and pressure at nominal operating conditions.

If the meter display indicates a temperature or pressure fault, a substitute value can be entered to allow flow calculations to continue at a fixed value until the source of the fault is identified and corrected. The units of measure of the displayed values are the same as the units configured for the flow meter.

Calibration Menu

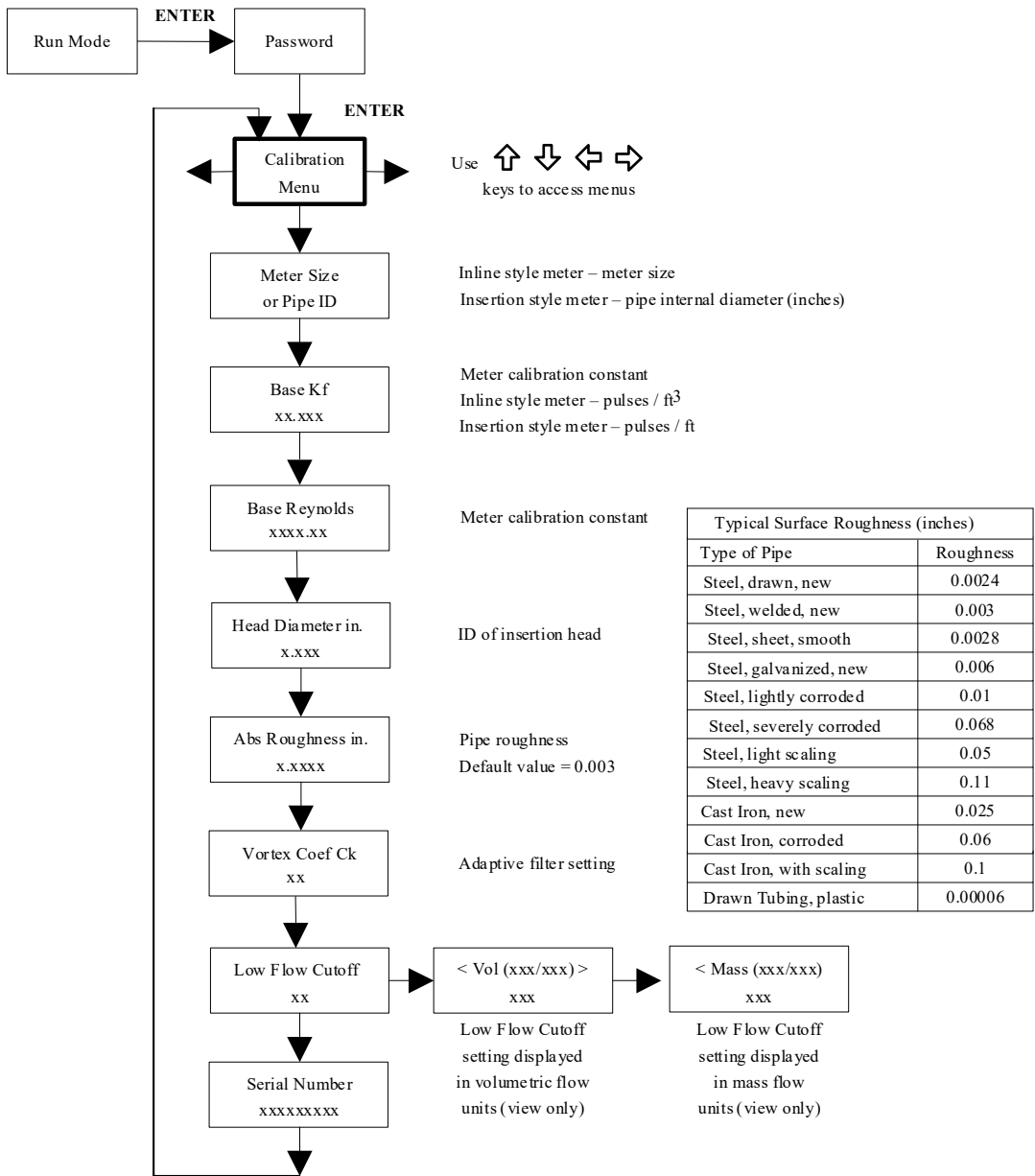

The Calibration Menu contains the calibration coefficients for the flow meter. These values should be changed only by properly trained personnel. The Vortex Coef Ck and Low Flow Cutoff are set at the factory. Consult the factory for help with these settings if the meter is showing erratic flow rate.

Password Menu

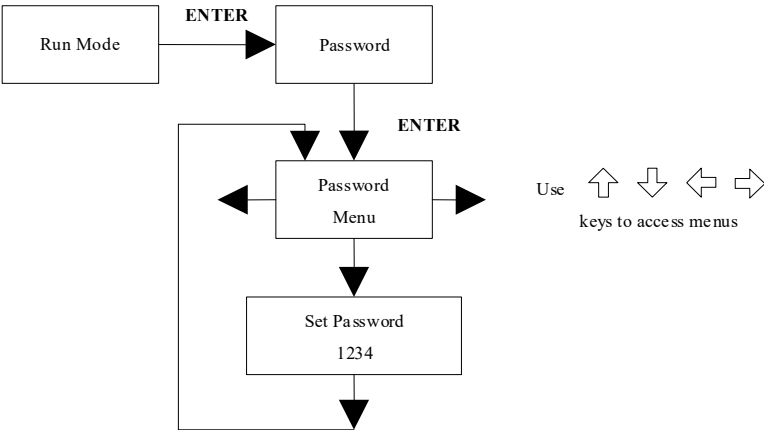

Use the Password Menu to set or change the system password. The factory-set password is 1234.

Chapter 4 Serial Communications

HART Communications

The HART Communications Protocol (Highway Addressable Remote Transducer Protocol) is a bidirectional digital serial communications protocol. The HART signal is based on the Bell 202 standard and is superimposed on 4-20 mA Output 1. Peer-to-peer (analog / digital) and multi-drop (digital only) modes are supported.

Wiring

The diagrams below detail the proper connections required for HART communications.

Loop Powered Meter Wiring



Warning!

Place controls in manual mode when making configuration changes to the vortex meter.

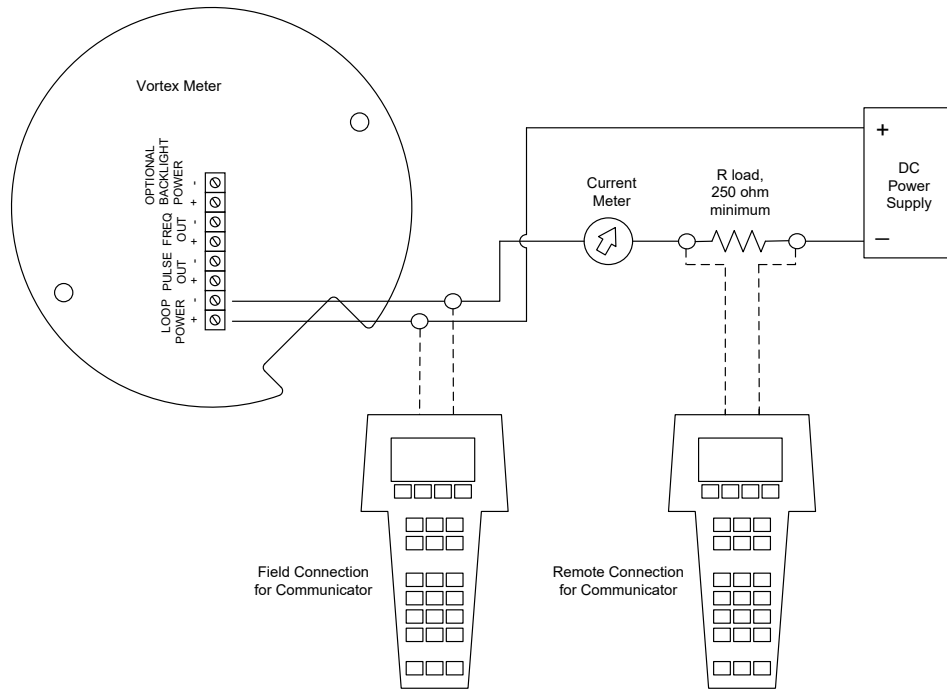

Figure 66 - Loop Powered Meter Wiring (HART)

DC Powered Meter Wiring

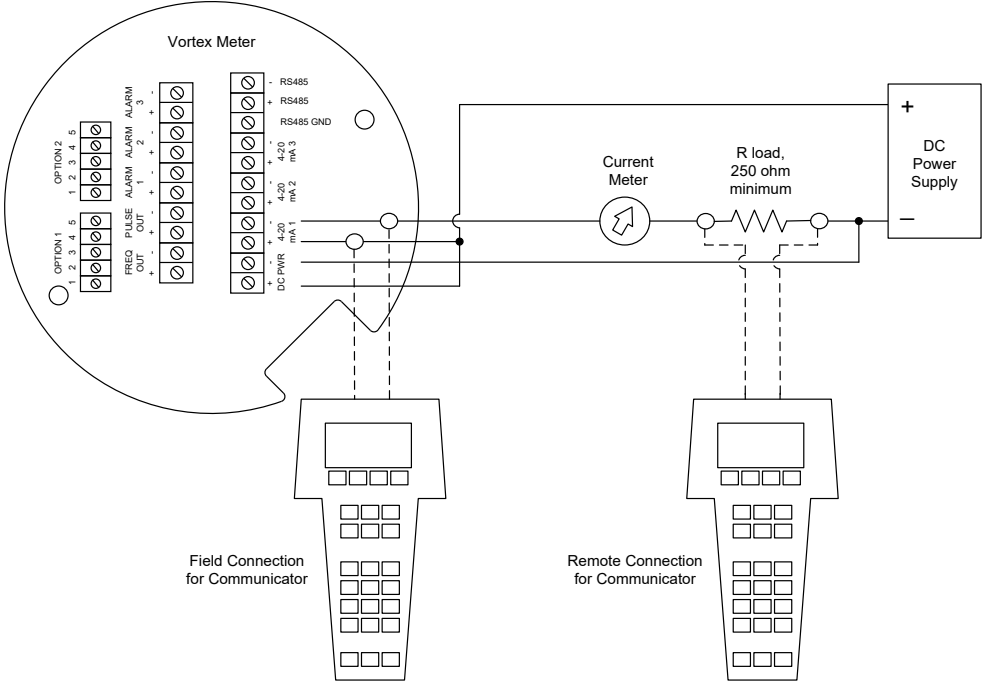

Figure 67 - DC Powered Meter Wiring (HART)

AC Powered Meter Wiring

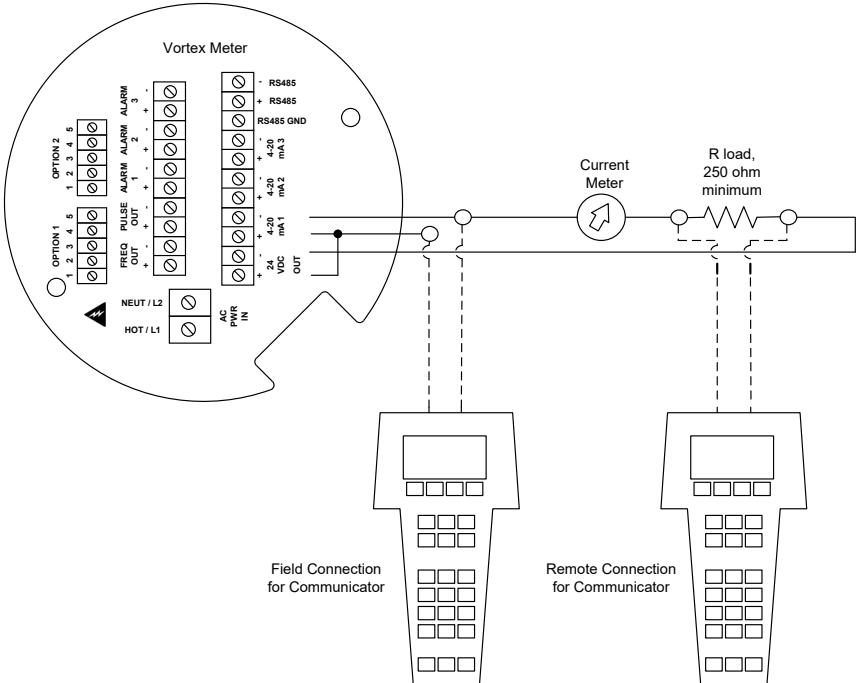
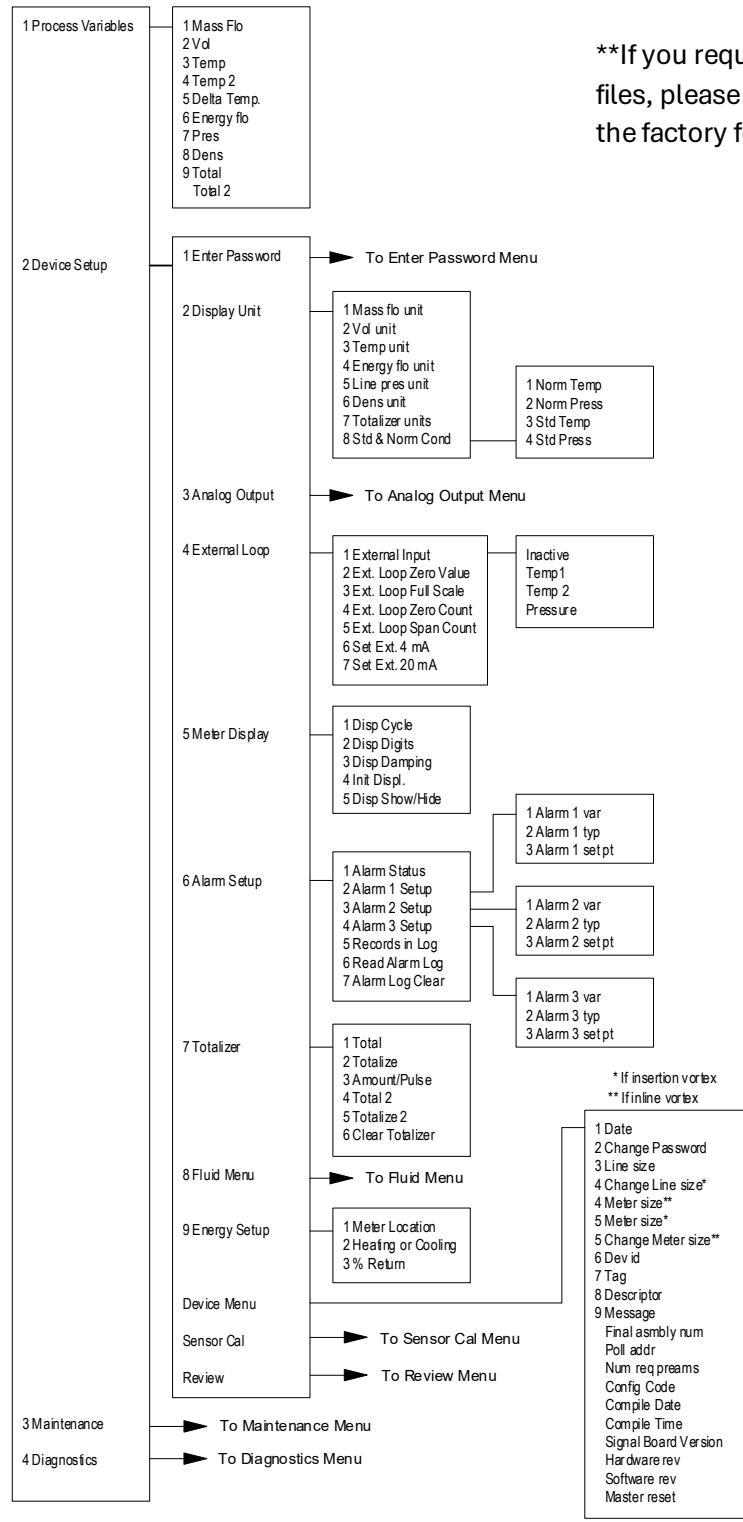

Figure 68 - AC Powered Meter Wiring (HART)

HART Commands with the DD Menu Online Menu



****If you require DD or DTM files, please reach out to the factory for a link.**

Analog Output Menu

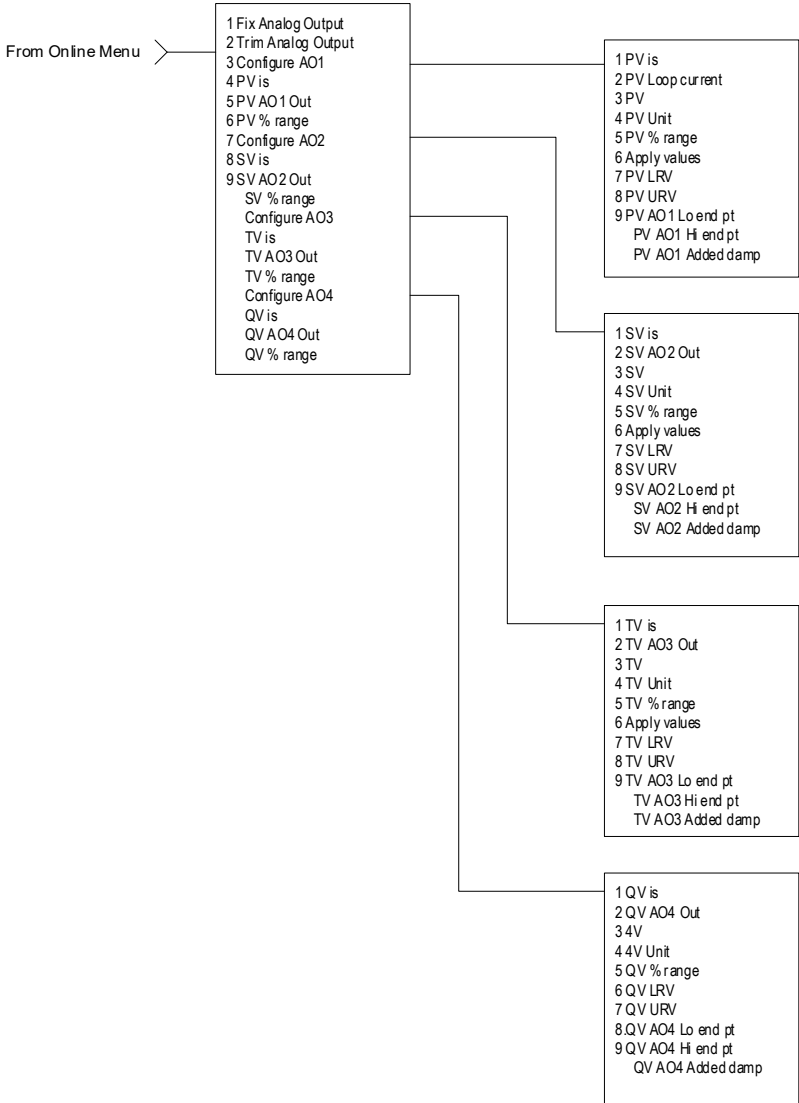

Fluid Menu

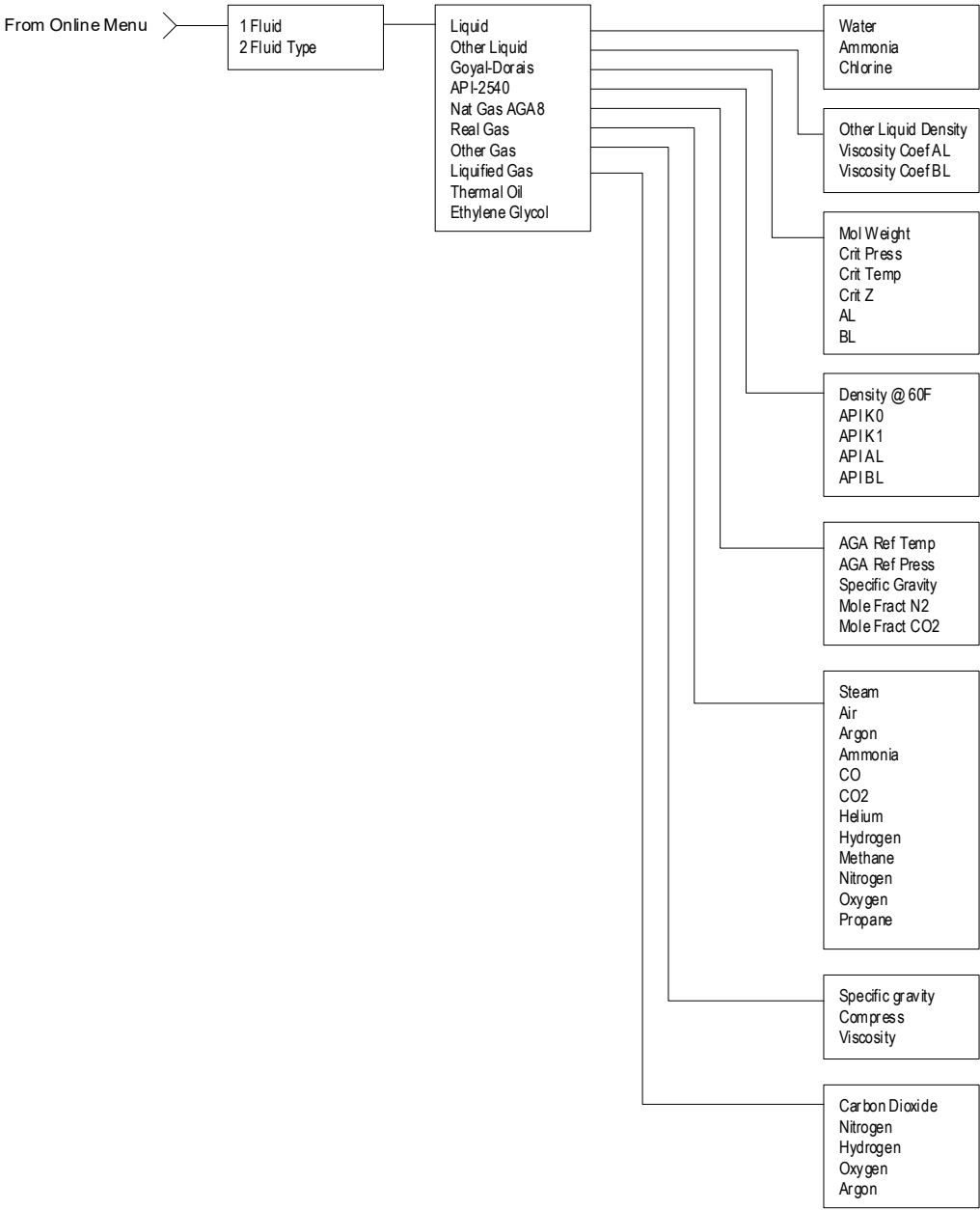

Maintenance Menu

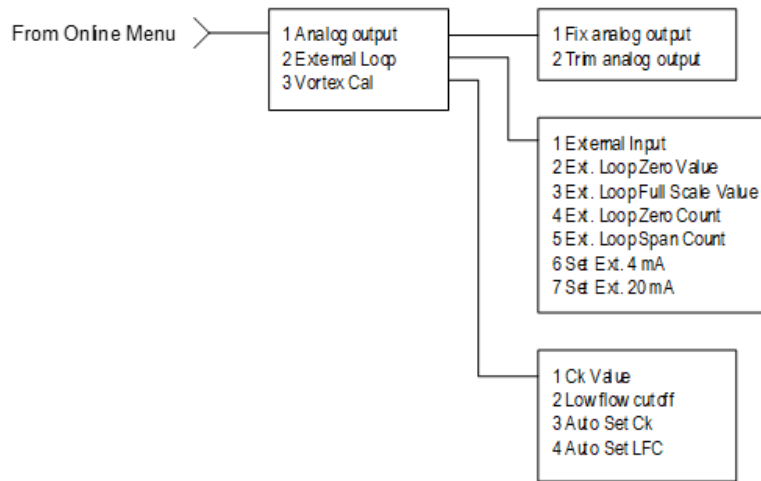

Diagnostics Menu

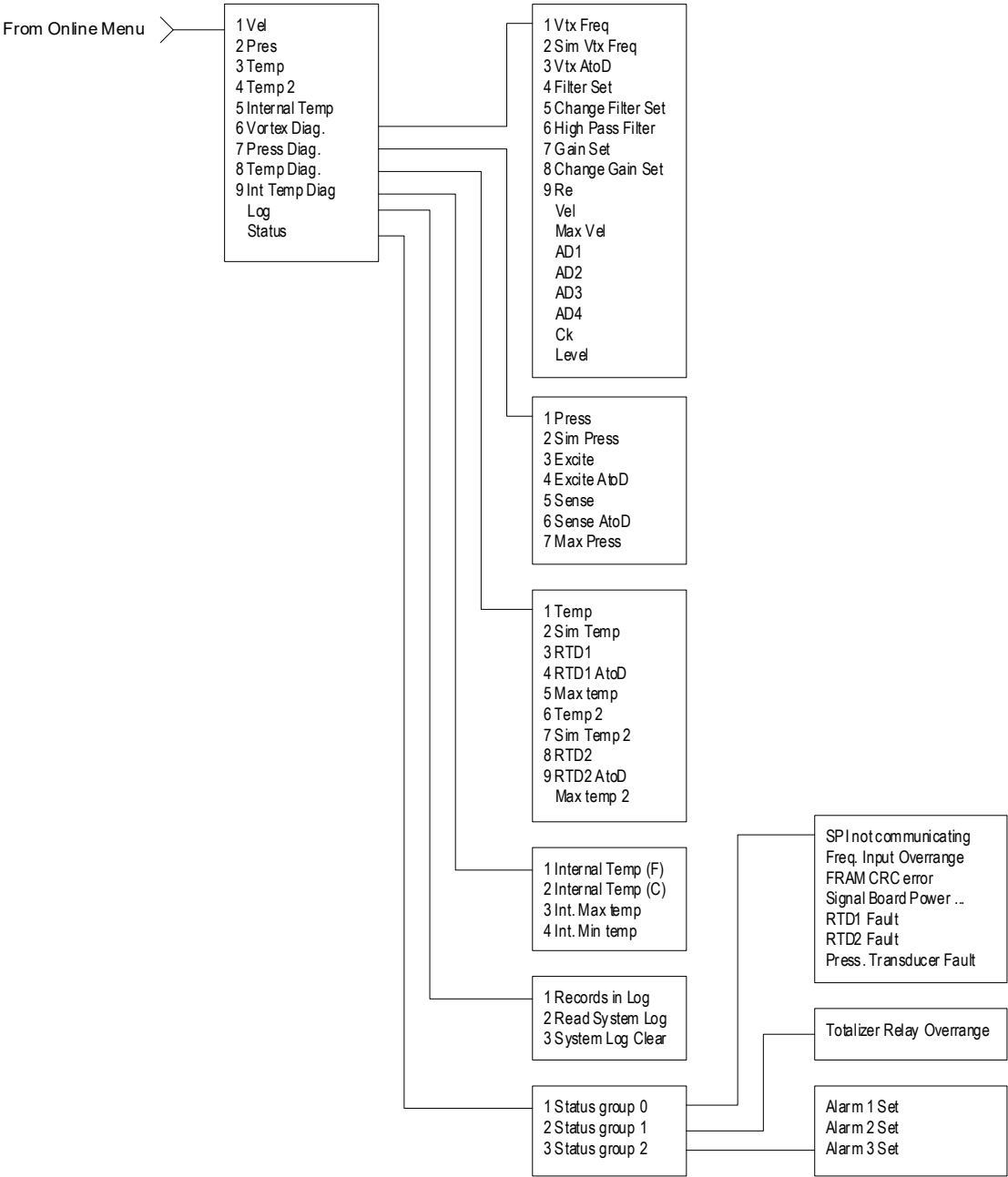

Review Menu

From Online Menu >

- 1 Model
- 2 Distributor
- 3 Write protect
- 4 Manufacturer
- 5 Dev id
- 6 Tag
- 7 Descriptor
- 8 Message
- 9 Date
- Final assembly num
- Universal rev
- File dev rev
- Software rev
- Poll addr
- Num req preams

Sensor Cal Menu

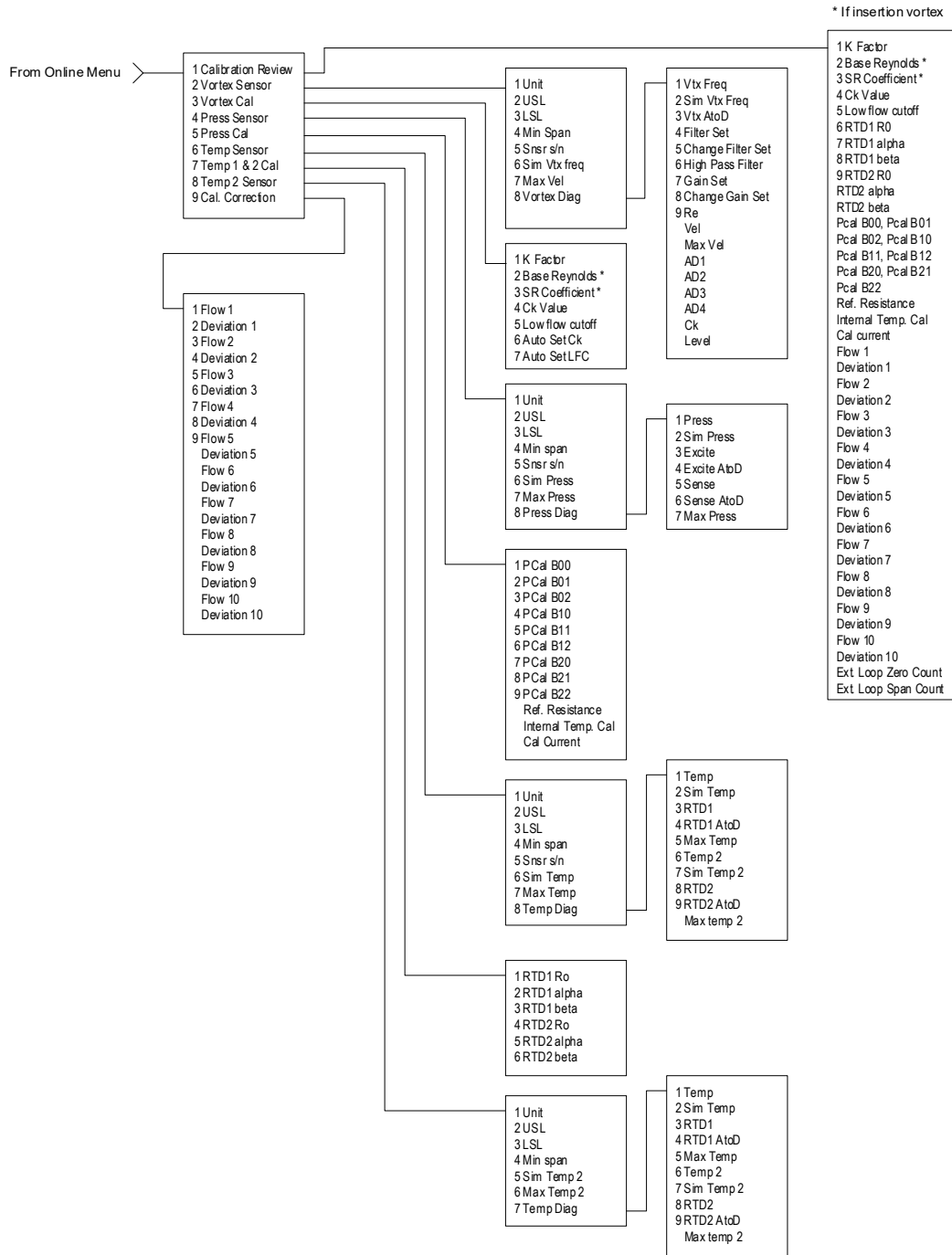

HART Commands with Generic DD Menu

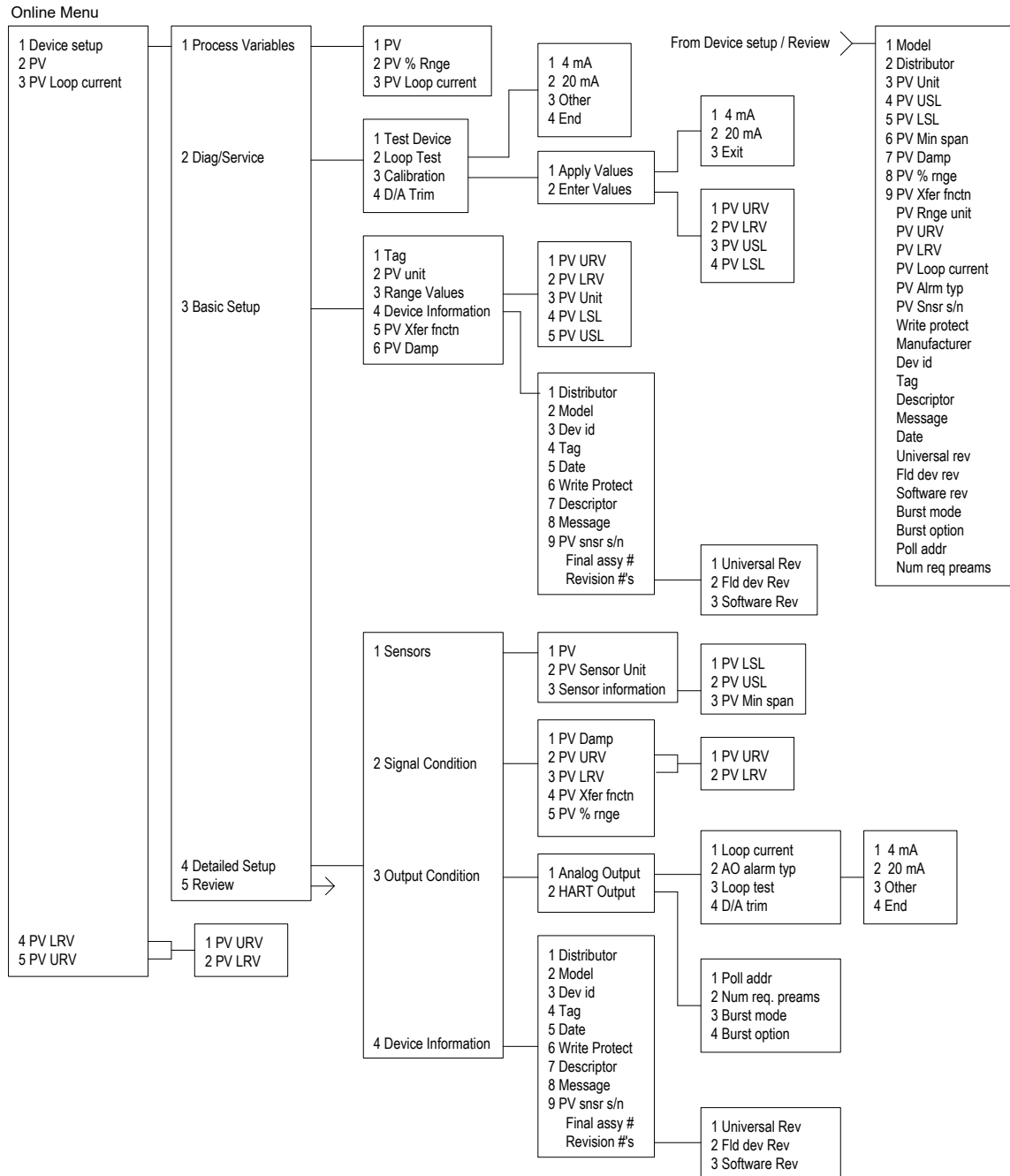

Modbus Communications



Warning!

Place controls in manual mode when making configuration changes to the vortex meter

Applicable Flow Meter Models

Sierra InnovaMass® Mass Flow Meters 240S and 241S with Modbus communication protocol and firmware version 4.00.58 and above.

Overview

This document describes the preliminary implementation of the Modbus communication protocol for use in monitoring common process variables in the Sierra InnovaMass® Vortex flow meter. The physical layer utilizes the half-duplex RS-485 port, and the Modbus protocol.

Reference Documents

The following documents are available online from www.modbus.org.

Modbus Application Protocol Specification V1.1

Modbus Over Serial Line Specification & Implementation Guide V1.0

Modicon Modbus Protocol Reference Guide PI-MBUS-300 Rev. J

Wiring

An RS485 daisy chained network configuration as depicted below is recommended. Do not use a star, ring, or cluster arrangement.

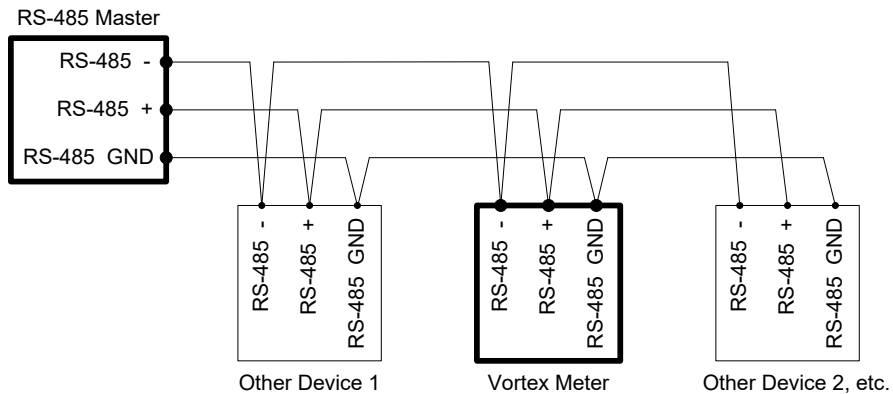

Figure 69 - RS-485 Wiring (MODBUS)

Pin Labeling Among Devices

“RS-485 –” = “A” = “TxD-/RxD-” = “Inverting pin”

“RS-485 +” = “B” = “TxD+/RxD+” = “Non-Inverting pin”

“RS-485 GND” = “GND” = “G” = “SC” = “Reference”

Menu Items

The following menu items are in the Output Menu and allow selection and control of the Modbus communication protocol.

Address

When the Modbus protocol is selected, the Modbus address is equal to the user programmable device address if it is in the range 1...247, in accordance with the Modbus specification. If the device address is zero or is greater than 247, then the Modbus address is internally set to 1.

Comm Protocol

The Comm Protocol menu allows selection of “Modbus RTU Even,” “Modbus RTU Odd,” “Modbus RTU None2,” or “Modbus RTU None1,” (non-standard Modbus) with Even, Odd and None referring to the parity selection. When even or odd parity is selected, the unit is configured for 8 data bits, 1 parity bit and 1 stop bit; with no parity, the number of stop bits is 1 (non-standard) or 2. When changing the protocol, the change is made as soon as the Enter key is pressed.

Modbus Units

The Modbus Units menu is to control what units, where applicable, the meter’s variables will be displayed in. Internal – these are the base units of the meter, °F, psia, lbm/sec, ft³/sec, Btu/sec, lbm/ft³ Display – variables are displayed in user selected display unit.

Modbus Order

The byte order within registers and the order in which multiple registers containing floating point or long integer data are transmitted may be changed with this menu item. According to the Modbus specification, the most significant byte of a register is transmitted first, followed by the least significant byte. The Modbus specification does not prescribe the order in which registers are transmitted when multiple registers represent values longer than 16 bits. Using this menu item, the order in which registers representing floating point or long integer data and/or the byte order within the registers may be reversed for compatibility with some PLCs and PC software.

The following four selections are available in this menu for byte order; when selecting an item, the protocol is changed immediately without having to press the ENTER key.

0-1:2-3	Most significant register first, most significant byte first (default)
2-3:0-1	Least significant register first, most significant byte first
1-0:3-2	Most significant register first, least significant byte first
3-2:1-0	Least significant register first, least significant byte first

	<p>Note All of the registers are affected by the byte order, including strings and registers representing 16-bit integers; the register order only affects the order of those registers representing 32-bit floating point and long integer data, but does not affect single 16-bit integers or strings</p>
---	--

Modbus Protocol

The Modbus RTU protocol is supported in this implementation. Supported baud rates are 1200, 2400, 4800, 9600, 19200, 38400, 57600, and 115200. The default baud rate is 19200 baud. Depending upon the Modbus protocol selected, data are transmitted in 8-bit data frames with even or odd parity and 1 stop bit, or no parity and 2 or 1 (non-standard) stop bits.

The current Modbus protocol specification does not define register usage, but there is an informal register numbering convention derived from the original (now obsolete) Modicon Modbus protocol specification and used by many vendors of Modbus capable products.

Registers	Usage	Valid Function Codes
00001–09999	Read/write bits ("coils")	01 (read coils) 05 (write single coil) 15 (write multiple coils)
10001–19999	Read-only bits ("discrete inputs")	02 (read discrete inputs)
30001–39999	Read-only 16 bit registers ("input registers"), IEEE 754 floating point register pairs, arbitrary length strings encoded as two ASCII characters per 16-bit register	03 (read holding registers) 04 (read input registers)
40001–49999	Read/write 16-bit registers ("holding registers"), IEEE 754 floating point register pairs, arbitrary length strings encoded as two ASCII characters per 16-bit register	03 (read holding registers) 06 (write single register) 16 (write multiple registers)

Each range of register numbers maps to a unique range of addresses that are determined by the function code and the register number. The address is equal to the least significant four digits of the register number minus one, as shown in the following table.

Registers	Function Codes	Data Type and Address Range
00001-09999	01, 05, 15	Read/write bits 0000-9998
10001-19999	02	Read-only bits 0000-9999
30001-39999	03, 04	Read-only 16-bit registers 0000-9998
40001-49999	03, 06, 16	Read/write 16-bit registers 0000-9998

Register Definitions

The meter serial number and those variables that are commonly monitored (mass, volume and energy flow rates, total, pressure, temperature, density, viscosity, Reynolds number, and diagnostic variables such as frequency, velocity, gain, amplitude and filter setting) are accessible via the Modbus protocol. Long integer and floating point numbers are accessed as pairs of 16-bit registers in the register order selected in the Modbus Order menu. Floating point numbers are formatted as single precision IEEE 754 floating point values.

The flow rate, temperature, pressure, and density variables may be accessed as either the flow meter internal base units or in the user-programmed display units, which is determined by the programming Output Menu's "Modbus Units" item. The display units strings may be examined by accessing their associated registers. Each of these units string registers contain 2 characters of the string, and the strings may be 2 to 12 characters in length with unused characters set to zero. Note that the byte order affects the order in which the strings are transmitted. If the Modbus Order menu (see page 102) is set to 0-1:2-3 or 2-3:0-1, then the characters are transmitted in the correct order; if set to 1-0:3-2 or 3-2:1-0, then each pair of characters will be transmitted in reverse order.

Registers	Variable	Data type	Units	Function code	Addresses
65101-65102	Serial Number	unsigned long	—	03, 04	65100-65101
30525-30526	Totalizer	unsigned long	display units*	03, 04	524-525
32037-32042	Totalizer Units	string	—	03, 04	2036-2041
30009-30010	Mass Flow	float	display units*	03, 04	8-9
30007-30008	Volume Flow	float	display units*	03, 04	6-7
30005-30006	Pressure	float	display units*	03, 04	4-5
30001-30002	Temperature	float	display units*	03, 04	0-1
30029-30030	Velocity	float	ft/sec	03, 04	28-29
30015-30016	Density	float	display units*	03, 04	14-15
30013-30014	Viscosity	float	cP	03, 04	12-13
30031-30032	Reynolds Number	float	—	03, 04	30-31
30025-30026	Vortex Frequency	float	Hz	03, 04	24-25
34532	Gain	char	—	03, 04	4531
30085-30086	Vortex Amplitude	float	Vrms	03, 04	84-85
30027-30028	Filter Setting	float	Hz	03, 04	26-27
30035-30036	RTD Resistance (0)	float	ohms	03, 04	34-35
30037-30038	RTD Resistance (1)	float	ohms	03, 04	36-37
30073-30074	Max. Velocity	float	display units*	03, 04	72-73
30075-30076	Max. Temperature	float	display units*	03, 04	74-75
30077-30078	Max. Temperature (1)	float	display units*	03, 04	76-77
30079-30080	Max. Pressure	float	display units*	03, 04	78-79
30097-30098	Glycol Weight %	float	%	03, 04	96-97
30099-30100	External Loop mA	float	mA	03, 04	98-99
30101-30102	Differential Pressure	float	display units*	03, 04	100-101

30501-30502	Volume Total	unsigned long	display units*	03, 04	500-501
30503-30504	Mass Total	unsigned long	display units*	03, 04	502-503
31521	Digital Alarm State (0)	byte	—	03, 04	1520
31522	Digital Alarm State (1)	byte	—	03, 04	1521
31523	Digital Alarm State (2)	byte	—	03, 04	1522
33001-33002	Simulated Vortex Frequency	float	—	03, 04	3000-3001
33003-33004	Simulated Temperature 0	float	—	03, 04	3002-3003
33005-33006	Simulated Temperature 1	float	—	03, 04	3004-3005
33007-33008	Simulated Pressure	float	—	03, 04	3006-3007
33009-33010	Insertion Pipe Diameter	float	—	03, 04	3008-3009
33101-33102	Unit per Pulse	float	—	03, 04	3100-3101
33115-33116	Ethylene Glycol %	float	—	03, 04	3114-3115
35001-35002	Meter Factor	float	—	03, 04	5000-5001
35003-35004	Low Flow Cutoff	float	—	03, 04	5002-5003
35005-35006	Ck	float	—	03, 04	5004-5005
38501-38502	Tag	string	—	03, 04	8500-8505

The following registers are available with the energy meter firmware:

Registers	Variable	Data type	Units	Function code	Addresses
30527-30528	Totalizer #2	unsigned long	display units*	03, 04	526-527
32043-32048	Totalizer #2 Units	string	—	03, 04	2042-2047
30003-30004	Temperature #2	float	display units*	03, 04	2-3
30011-30012	Energy Flow	float	display units*	03, 04	10-11
30017-30018	Fluid Enthalpy (0)	float	BTU/lb	03, 04	16-17
30019-30020	Fluid Enthalpy (1)	float	BTU/lb	03, 04	18-19
30191-30192	Delta Temperature	float	display units*	03, 04	190-191
30505-30506	Energy Total	unsigned long	display units*	03, 04	504-505
30507-30508	Reverse Energy Total	unsigned long	display units*	03, 04	506-507
30543-30544	Net Energy Total	unsigned long	display units*	03, 04	542-543

The following registers contain the display units strings:

Registers	Variable	Data type	Units	Function code	Addresses
32007-32012	Volume Flow Units	string	—	03, 04	2006-2011
32001-32006	Mass Flow Units	string	—	03, 04	2000-2005
32025-32030	Temperature Units	string	—	03, 04	2024-2029
32019-32024	Pressure Units	string	—	03, 04	2018-2023
32031-32036	Density Units	string	—	03, 04	2030-2035
32013-32017	Energy Flow Units	string	—	03, 04	2012-2017
32055-32060	Volume Total Units	string	—	03, 04	2054-2059
32061-32066	Mass Total Units	string	—	03, 04	2060-2065
32067-32072	Energy Total Units	string	—	03, 04	2066-2071

Function codes 03 (read holding registers) and 04 (read input registers) are the only codes supported for reading these registers, and function codes for writing holding registers are not implemented. We recommend that the floating point and long integer registers be read in a single operation with the number of registers being a multiple of two. If these data are read in two separate operations, each reading a single 16-bit register, then the value will likely be invalid.

The floating point registers with values in display units are scaled to the same units as are displayed, but are instantaneous values that are not smoothed. If display smoothing is enabled (non-zero value entered in the Display TC item in the Display Menu), then the register values will not agree exactly with the displayed values.

Exception Status Definitions

The Read Exception Status command (function code 07) returns the exception status byte, which is defined as follows. This byte may be cleared by setting “coil” register #00008 (function code 5, address 7, data = 0xff00).

Bit(s)	Definition
0-1	Byte order (see Modbus Order on page 102) 0 = 3-2:1-0 1 = 2-3:0-1 2 = 1-0:3-2 3 = 0-1:2-3
2	Not used
3	Not used
4	Not used
5	Not used
6	Not used
7	Configuration changed

Control Register Definitions

The only writeable registers in this implementation are the Reset Exception Status, Reset Meter and Reset Totalizer functions, which are implemented as "coils" which may be written with the Write Single Coil command (function code 05) to address 0 through 9, respectively, (register #00001 through #00010). The value sent with this command must be either 0x0000 or 0xff00, or the meter will respond with an error message; the totalizer will be reset or exception status cleared only with a value of 0xff00.

The following registers contain the reset functions:

Registers	Variable	Value	Units	Function code	Coil #
00001	Reset Volume Total	0xFF00	—	05	0
00002	Reset Mass Total	0xFF00	—	05	1
00003	Reset Energy Total	0xFF00	—	05	2
00004	Reset Reverse Energy Total	0xFF00	—	05	3
00008	Reset Exception Status	0xFF00	—	05	7
00009	Reset Meter	0xFF00	—	05	8
00010	Reset Totals	0xFF00	—	05	9

Error Responses

If an error is detected in the message received by the unit, the function code in the response is the received function code with the most significant bit set, and the data field will contain the exception code byte, as follows:

Exception Code	Description
01	Invalid function code — function code not supported by device
02	Invalid data address — address defined by the start address and number of registers is out of range
03	Invalid data value — number of registers = 0 or > 125 or incorrect data with the Write Single Coil command

If the first byte of a message is not equal to the unit's Modbus address, if the unit detects a parity error in any character in the received message (with even or odd parity enabled), or if the message CRC is incorrect, the unit will not respond.

Command Message Format

The start address is equal to the desired first register number minus one. The addresses derived from the start address and the number of registers must all be mapped to valid defined registers, or an invalid data address exception will occur.

Device Address	Function Code	Start Address	N = Number of Registers	CRC
8 bits, 1...247	8 bits	16 bits, 0...9998	16 bits, 1...125	16 bits

Normal Response Message Format

Device Address	Function Code	Byte Count = 2 x N	Data	CRC
8 bits, 1...247	8 bits	8 bits	(N) 16-bit registers	16 bits

Exception Response Message Format

Device Address	Function Code + 0x80	Exception Code	CRC
8 bits, 1...247	8 bits	8 bits	16 bits

Examples:

Read the exception status byte from the device with address 1:

```
01 07 41 E2
```

```
01 Device address
07 Function code, 07 = read exception status
41 E2 CRC
```

A typical response from the device is as follows:

```
01 07 03 62 31
```

```
01 Device address
07 Function code
03 Exception status byte
62 31 CRC
```

Request the first 12 registers from device with address 1:

```
01 04 00 00 00 0C F0 0F
```

```
01 Device address
04 Function code, 04 = read input register
00 00 Starting address
00 0C Number of registers = 12
F0 0F CRC
```

A typical response from the device is as follows:

****Note, these are the older register definitions**

```
01 04 18 00 00 03 E8 00 00 7A 02 6C 62 00 00 41 BA 87 F2 3E BF FC 6F 42 12 EC 8B 4D
D1
```

```
01 Device address
04 Function code
18 Number of data bytes = 24
00 00 03 E8 Serial number = 1000 (unsigned long)
00 00 7A 02 Totalizer = 31234 lbm (unsigned long)
6C 62 00 00 Totalizer units = "lb" (string, unused characters are 0)
41 BA 87 F2 Mass flow rate = 23.3164 lbm/sec (float)
3E BF FC 6F Volume flow rate = 0.3750 ft3/sec (float)
42 12 EC 8B Pressure = 36.731 psia (float)
4D D1 CRC
```

An attempt to read register(s) that don't exist:

```
01 04 00 00 00 50 F1 D2
```

```
01 Device address
04 Function code 4 = read input register
00 00 Starting address
00 50 Number of registers = 80
F0 36 CRC
```

Results in an error response as follows:

```
01 84 02 C2 C1
```

```
01 Device address
84 Function code with most significant bit set indicates error response
02 Exception code 2 = invalid data address
C2 C1 CRC
```

Request the state all three alarms:

01 02 00 00 00 03 38 0B

01 Device address
 02 Function code 2 = read discrete inputs
 00 00 Starting address
 00 03 Number of inputs = 3
 38 0B CRC

and the unit responds with:

01 02 01 02 20 49

01 Device address
 02 Function code
 01 Number of data bytes = 1
 02 Alarm #2 on, alarms #1 and #3 off
 20 49 CRC

To reset the totalizer:

01 05 00 00 FF 00 8C 3A

01 Device address
 05 Function code 5 = write single coil
 00 09 Coil address = 9
 FF 00 Data to reset totalizer
 5C 38 CRC

The unit responds with an identical message to that transmitted, and the totalizer is reset. If the “coil” is turned off as in the following message, the response is also identical to the transmitted message, but the totalizer is not affected.

01 05 00 09 00 00 1D C8

01 Device address
 05 Function code 5 = write single coil
 00 09 Coil address = 9
 00 00 Data to “turn off coil” does not reset totalizer
 1D C8 CRC

BACnet MS/TP Communications

Description

The BACnet Master-Slave/Token-Passing (MSTP) driver implements a data link protocol that uses the services of the RS-485 physical layer. The MS/TP bus is based on BACnet standard protocol SSPC-135, Clause 9. BACnet MS/TP protocol is a peer-to-peer, multiple master protocols based on token passing. Only master devices can receive the token, and only the device holding the token is allowed to originate a message on the bus. The token is passed from master device to master device using a small message. The token is passed in consecutive order starting with the lowest address. Slave devices on the bus only communicate on the bus when responding to a data request from a master device.

Wiring

An RS485 daisy chained network configuration as depicted below is recommended. Do not use a star, ring, or cluster arrangement.

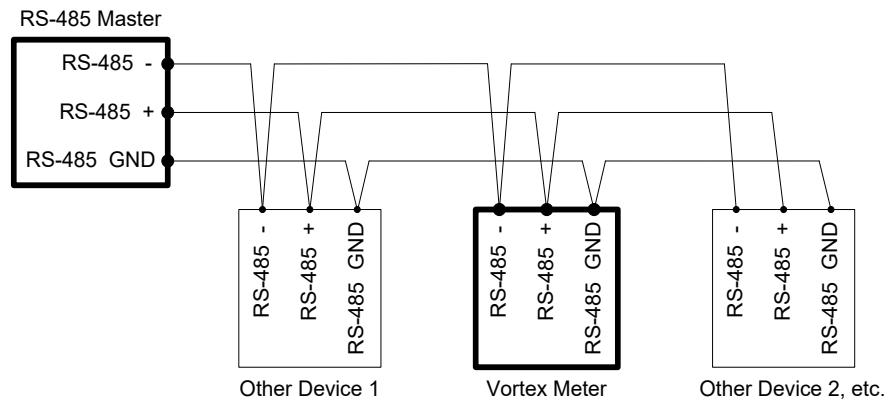

Figure 70 - RS-485 Wiring (BACnet)

Pin Labeling Among Devices

“RS-485 -” = “A” = “TxD-/RxD-” = “Inverting pin”

“RS-485 +” = “B” = “TxD+/RxD+” = “Non-Inverting pin”

“RS-485 GND” = “GND” = “G” = “SC” = “Reference”

Baud Rates on the MS/TP Bus

An MS/TP bus can be configured to communicate at one of four different baud rates. It is very important that all of the devices on an MS/TP bus communicate at the same baud rate. The baud rate setting determines the rate at which devices communicate data over the bus. The baud rate settings available on InnovaMass® Vortex Mass Flow Meters are 9600, 19200 and 38400.

Baud Rate and MAC Address Configuration Setup

1. Power on the IUT.
2. Enter the factory password 16363 (Use UP and DOWN arrows to enter the digits).
3. Navigate with the left arrow to Diagnostics Menu.
4. Press ENTER and press RIGHT button immediately.
5. Navigate to Config Code screen by continuous pressing DOWN button.
6. After reaching Config Code screen, press RIGHT to navigate to Comm. Type screen.
7. Press ENTER and change the Comm. Type to “BACnet.” Press ENTER to save.

Note: BACnet will enable Baud Rate and MAC address screens

8. Press EXIT twice to go back to the Diagnostics Menu.
9. Navigate to Output Menu by using RIGHT or LEFT arrow buttons.
10. Press DOWN button and reach Baud Rate and MAC address screens.
11. Change the required settings and press EXIT & ENTER button to save the configuration.
12. Reboot the device by power off and on for the changes to take effect.

Note:

- a. IUT support 9600, 19200, 38400 baud rates
- b. MAC address range is 0-127

Supported BACnet Objects

A BACnet object represents physical or virtual equipment information, as a digital input or parameters. The InnovaMass® Vortex Mass Flow Meters presents the following object types:

1. Device Object
2. Analog Input
3. Binary Input
4. Binary Value

Each object type defines a data structure composed of properties that allow the access to the object information. The below table shows the implemented properties for each Vortex Mass Flow Meters object type.

Properties	Object Types			
	Device	Analog Input	Binary Input	Binary Value
Object_Identifier	<input checked="" type="checkbox"/>	<input checked="" type="checkbox"/>	<input checked="" type="checkbox"/>	<input checked="" type="checkbox"/>
Object_Name	<input checked="" type="checkbox"/>	<input checked="" type="checkbox"/>	<input checked="" type="checkbox"/>	<input checked="" type="checkbox"/>
Object_Type	<input checked="" type="checkbox"/>	<input checked="" type="checkbox"/>	<input checked="" type="checkbox"/>	<input checked="" type="checkbox"/>
System_Status	<input checked="" type="checkbox"/>			
Vendor_Name	<input checked="" type="checkbox"/>			
Vendor_Identifier	<input checked="" type="checkbox"/>			
Model_Name	<input checked="" type="checkbox"/>			
Firmware_Revision	<input checked="" type="checkbox"/>			
Application-Software-Version	<input checked="" type="checkbox"/>			
Protocol_Version	<input checked="" type="checkbox"/>			
Protocol_Revision	<input checked="" type="checkbox"/>			
Protocol_Services_Supported	<input checked="" type="checkbox"/>			
Protocol_Object_Types_Supported	<input checked="" type="checkbox"/>			
Object_List	<input checked="" type="checkbox"/>			
Max_ADPU_Length_Accepted	<input checked="" type="checkbox"/>			
Segmentation_Supported	<input checked="" type="checkbox"/>			
ADPU_Timeout	<input checked="" type="checkbox"/>			
Number_Of_ADPU_Retries	<input checked="" type="checkbox"/>			
Max_Masters	<input checked="" type="checkbox"/>			
Max_Info_Frames	<input checked="" type="checkbox"/>			
Device_Address_Binding	<input checked="" type="checkbox"/>			
Database_Revision	<input checked="" type="checkbox"/>			
Status_Flags				
Event_State		<input checked="" type="checkbox"/>	<input checked="" type="checkbox"/>	<input checked="" type="checkbox"/>
Reliability				
Out_Of_Service		<input checked="" type="checkbox"/> (W)	<input checked="" type="checkbox"/> (W)	<input checked="" type="checkbox"/> (W)
Units		<input checked="" type="checkbox"/>		
Polarity			<input checked="" type="checkbox"/> (W)	
Priority_Array				
Relinquish_Default				
Status_Flag		<input checked="" type="checkbox"/>	<input checked="" type="checkbox"/>	<input checked="" type="checkbox"/>
Present_Value		<input checked="" type="checkbox"/> (W)	<input checked="" type="checkbox"/> (W)	<input checked="" type="checkbox"/> (W)
Inactive_Text				
Active_Text				

(W) – Writable Property.

Device Object

The Device object default property values are as follows:

Property Name	Default Values
object-identifier	7
object-name	Device,1
object-type	Device
system-status	operational
vendor-name	Sierra
vendor-identifier	772
model-name	Multivariable Flowmeter
firmware-revision	N/A
application-software-version	1.07
protocol-version	1
protocol-revision	4
protocol-services-supported	{F,F,F,F,F,F,F,F,F,F,F,T,F,T,T,T,T,F,F,F,F,F,F,F,F,F,F,T,T,F,F,F,F}
protocol-object-types-supported	{T,F,F,T,F,T,F,F,T,F,F,F,F,F,F,F,F,F,F,F,F,F}
object-list	{(analog-input,1),(analog-input,2),(analog-input,3),(analog-input,4), (analog-input,5), (analog-input,6),(analog-input,7),(analog-input,8) (analog-input,9),(analog-input,10), (analog-input,11), (analog-input,12), (analog-input,13),(analog-input,14), (analog-input,15),(analog-input,16),(analog-input,17), (analog-input,18),(analog-input,19),(binary-input,1),(binary-input,2),(binary-input,3),(binary-input,4), (binary-value,1), (device,7) }
max-apdu-length-accepted	300
segmentation-supported	no-segmentation
apdu-timeout	3000
number-of-APDU-retries	1
max-master	127
max-info-frames	1
device-address-binding	()
database-revision	0

Note - Device Communication Control: Password – “sierra”

Analog Input Object

Vortex Mass Flow Meters Analog Input type objects are described below:

Object Instance	Object Name	Unit	Description
1	Volume Flow	cubic-feet-per-second, cubic-feet-per-minute, us-gallons-per-minute, imperial-gallons-per-minute, liters-per-minute, liters-per-second, liters-per-hour, cubic-meters-per-second, cubic-meters-per-minute, cubic-meters-per-hour	This AI object is used to measure volume flow.
2	Mass Flow	pounds-mass-per-second, grams-per-second, kilograms-per-second , kilograms-per-minute , kilograms-per-hour, pounds-mass-per-minute , pounds-mass-per-hour, tons-per-hour, grams-per-second , grams-per-minute	This AI object is used to measure mass flow.
3	Temperature 1	degrees-Celsius, degrees-Kelvin, degrees-Fahrenheit	This AI object measures Temperature in one of the given Unit.
4	Temperature 2	degrees-Celsius, degrees-Kelvin, degrees-Fahrenheit	This AI object measures Temperature in one of the given Unit.
5	Pressure	pounds-force-per-square-inch, inches-of-water, inches-of-mercury, millimeters-of-mercury, bars, millibars, pascals, kilopascals	TBD
6	Density	kilograms-per-cubic-meter	TBD
7	Energy Flow	Kilowatts, Horsepower, btus-per-hour, kilo-btus-per-hour, megawatts	TBD
8	Totalizer 1 & Totalizer 2	If Totalizer selection for Mass measure – pounds-mass-per-second,	An electronic counter which records the total

		grams-per-second, kilograms-per-second, kilograms-per-minute, kilograms-per-hour, pounds-mass-per-minute, pounds-mass-per-hour, tons-per-hour, grams-per-second, grams-per-minute If Totalizer selection for Volume measure – cubic-feet-per-second, cubic-feet-per-minute, us-gallons-per-minute, imperial-gallons-per-minute, liters-per-minute, liters-per-second, liters-per-hour, cubic-meters-per-second, cubic-meters-per-minute, cubic-meters-per-hour If Totalizer selection for Energy measure – Kilowatts, Horsepower, btus-per-hour, kilo-btus-per-hour, megawatts	accumulated flow over a certain range of time.
10	StatusRegister	NO UNITS	TBD
11	Channel 1 (4-20mA)	milliamperes	TBD
12	Channel 2 (4-20mA)	milliamperes	TBD
13	Channel 3 (4-20mA)	milliamperes	TBD
14	Scaled Freq	hertz	TBD
15	Flow Velocity	feet-per-second	TBD
16	Viscosity	centipoises	TBD
17	Frequency	hertz	TBD
18	Vortex Amp	millivolts	TBD
19	FilterSetting	hertz	TBD

Binary Input Object

Vortex Mass Flow Meters Binary Input type objects are described below:

Object Instance	Object Name	Description
1	Alarm1	The status of the three alarms may be monitored via the Modbus command. The value returned indicates the state of the alarm and will be 1 only if the alarm is enabled and active. A zero value is transmitted for alarms that are either disabled or inactive
2	Alarm2	
3	Alarm3	
4	External	TBD

Note - Binary Input 4, Present value always read zero, because no information available from client, so the polarity property doesn't impact on Present value property when the Out of service property is false.

Binary Value Object

Vortex Mass Flow Meters Binary Value type objects are described below:

Object Instance	Object Name	Description
1	Reset	Resets Totalizer

ANNEX – BACnet Protocol Implementation Conformance Statement

Date: 19-April-2012

Vendor Name: Sierra Instruments

Product Name: InnovaMass 240S/241S multivariable flow-meter

Product Model Number: 240S/241S/240S-R VT/VTP

Applications Software Version: 1.07

Firmware Revision: N/A

BACnet Protocol Revision: 4

Product Description: Sierra multivariable flow-meter

Annex L – BACnet Standardized Device Profile

- BACnet Operator Workstation (B-OWS)
- BACnet Advanced Operator Workstation (B-AWS)
- BACnet Operator Display (B-OD)
- BACnet Building Controller (B-BC)
- BACnet Advanced Application Controller (B-AAC)
- BACnet Application Specific Controller (B-ASC)
- BACnet Smart Sensor (B-SS)
- BACnet Smart Actuator (B-SA)

Annex K – All BACnet Interoperability Building Blocks Supported

BIBBs
DS-RP-B
DS-WP-B
DM-DDB-B
DM-DOB-B
DM-DCC-B
DS-RPM-B
DS-WPM-B

Services Supported	
Read Property	Execute
Write Property	Execute
Read Property Multiple	Execute
Write Property Multiple	Execute
Who-Is	Execute
I-Am	Initiate
Who-Has	Execute
I-Have	Initiate
Device Communication Control	Execute

Segmentation Capability:

- Able to transmit segmented messages Window Size
- Able to receive segmented messages Window Size

Standard Object Types Supported

Standard Object Types Supported				
Object Type	Dynamically Creatable	Dynamically Delete-able	Additional Writable Properties	Range Restrictions
Analog Input (AI)	No	No	None	None
Binary Input (BV)	No	No	None	None
Binary Value	No	No	None	None
Device	No	No	None	None

Standard Object Types Supported Writable Properties			
Object Type	Properties		
Analog Input (AI)	Present Value	Out-Of-Service	
Binary Input (BV)	Present Value	Out-Of-Service	Polarity
Binary Value	Present Value	Out-Of-Service	
Device			

Object List

Properties of Analog Input/Value Objects Type						
ID	Name	Present Value	Status Flags	Event State	Out of Service	Units
AI1	Volume Flow	?	F,F,F,F	Normal	False	?
AI2	Mass Flow	?	F,F,F,F	Normal	False	?
AI3	Temperature 1	?	F,F,F,F	Normal	False	?
AI4	Temperature 2	?	F,F,F,F	Normal	False	?
AI5	Pressure	?	F,F,F,F	Normal	False	?
AI6	Density	?	F,F,F,F	Normal	False	?
AI7	Energy Flow	?	F,F,F,F	Normal	False	?
AI8	Totalizer 1	?	F,F,F,F	Normal	False	?
AI9	Totalizer 2	?	F,F,F,F	Normal	False	?
AI10	StatusRegister	?	F,F,F,F	Normal	False	?
AI11	Channel 1 (4-20mA)	?	F,F,F,F	Normal	False	?
AI12	Channel 2 (4-20mA)	?	F,F,F,F	Normal	False	?
AI13	Channel 3 (4-20mA)	?	F,F,F,F	Normal	False	?
AI14	Scaled Freq	?	F,F,F,F	Normal	False	?
AI15	Flow Velocity	?	F,F,F,F	Normal	False	?
AI16	Viscosity	?	F,F,F,F	Normal	False	?
AI17	Frequency	?	F,F,F,F	Normal	False	?
AI18	Vortex Amp	?	F,F,F,F	Normal	False	?
AI19	FilterSetting	?	F,F,F,F	Normal	False	?

Properties of Analog Input/Value Objects Type						
ID	Name	Present Value	Status Flags	Event State	Out of Service	Polarity
BI1	Alarm1	?	F,F,F,F	Normal	False	Normal
BI2	Alarm2	?	F,F,F,F	Normal	False	Normal
BI3	Alarm3	?	F,F,F,F	Normal	False	Normal
BI4	External	?	F,F,F,F	Normal	False	Normal

Properties of Analog Input/Value Objects Type						
ID	Name	Present Value	Status Flags	Event State	Out of Service	Out of Service
BV1	Reset	?	F,F,F,F	Normal	False	False

Data Link Layer Options

- BACnet IP, (Annex J)
- BACnet IP, (Annex J), Foreign Device
- ISO 8802-3, Ethernet (Clause 7)
- ANSI/ATA 878.1, 2.5 Mb. ARCNET (Clause 8)
- ANSI/ATA 878.1, EIA-485 ARCNET (Clause 8), baud rate(s)
- MS/TP master (Clause 9), baud rate(s): 9600, 19200, 38400
- MS/TP slave (Clause 9), baud rate(s):
- Point-To-Point, EIA 232 (Clause 10), baud rate(s):
- Point-To-Point, modem, (Clause 10), baud rate(s):
- LonTalk, (Clause 11), medium:
- Other:

Device Address Binding

Is static device binding supported? (This is currently necessary for two-way communication with MS/TP slaves and certain other devices.):

- Yes
- No

Networking Options

- Router, Clause 6 - List all routing configurations, e.g., ARCNET-Ethernet, Ethernet-MS/TP, etc.
- Annex H, BACnet Tunneling Router over IP
- BACnet/IP Broadcast Management Device (BBMD)

Does the BBMD support registrations by Foreign Devices?

- Yes
- No

Does the BBMD support network address translation?

- Yes
- No

Network Security Options

- Non-secure Device - is capable of operating without BACnet Network Security
- Secure Device - is capable of using BACnet Network Security (NS-SD BVBB)
- Multiple Application-Specific Keys:
- Supports encryption (NS-ED BVBB)
- Key Server (NS-KS BVBB)

Character Sets Supported

Indicating support for multiple character sets does not imply that they can all be supported simultaneously.

- ANSI X3.4
- IBM™/Microsoft™DBCS
- ISO 8859-1
- ISO 10646 (UCS-2)
- ISO 10646 (UCS-4)
- JIS C 6226

If this product is a communication gateway, describe the types of non-BACnet equipment/networks(s) that the gateway supports: N/A

Acronyms and Definitions

Item	Description
APDU	Application Protocol Data Unit
BACnet	Building Automation and Control Network- Data communication protocol
MS/TP	Master-Slave Token passing (a twisted pair RS485 network created by BACnet)
BIBB	BACnet Interoperability Building Block (Specific individual function blocks for data exchange between interoperable devices).
BV	Binary Value
BI	Binary Input
AI	Analog Input
RP	Read Property
WP	Write Property
RPM	Read Property Multiple
WPM	Write Property Multiple.
DDB	Dynamic Device Binding
DOB	Dynamic Object Binding
DCC	Device communication Control

POE Communications

Direct Connection Options

The unit must be powered by DC power or ethernet cable (see page 50). If using DC powering option, connect a standard ethernet cable to your PC and the unit. If using POE, ensure the switch is connected to your PC.

For testing and initial setup purposes, one may use direct connection to PC or Laptop. After reconnecting, you need to cycle the power to the meter. The meter will display the current IP address on the screen. Once the unit is connected it will try to request an IP address from the nonexistent DHCP server and then switch to AutoIP address (unfortunately random), for example 169.254.xxx.xxx.

If you could not see the IP address after cycling the meters power, you can run the IPSetup utility program. See more instructions on how to use the IPSetup program below in Network Configuration (see page 124). Once you find out assigned meter IP address or the NetBios name <http://VRTXXXXX>, type one of them into a browser to connect to the unit.

Connection Issues

The common issue is that PC does not recognize the plugged Ethernet cable. You may have to disable/enable Ethernet adapter to force it to “see” connected cable.

Alternatively, you may use static IP setting for both your PC and meter. The addresses should be on the same network, like 192.168.1.xxx or 10.10.10.xxx.

Tip: To quickly find Microsoft Network configuration page, type WindowsKey+R and in command window enter “ncpa.cpl”

Network Configuration

Sierra/TCP meter needs to be configured in order to be “visible” on your local network. There are two methods of configuration:

- Static IP address
- Dynamically assigned IP address via DHCP (Dynamic Host Configuration Protocol)

For static configuration consult your network administrator which IP address to use. To set up your Static IP address on Windows, follow the below instructions.

1. Open your “Network and Internet Settings” and then click on “Change adapter options.”

Status

Network status



You're connected to the Internet

If you have a limited data plan, you can make this network a metered connection or change other properties.

Wi-Fi 3.93 GB
From the last 30 days

Properties

Data usage

Ethernet 4
From the last 30 days

Properties

Data usage

Show available networks
View the connection options around you.

Advanced network settings

Change adapter options
View network adapters and change connection settings.

Network and Sharing Center

2. Right click on “Wireless Network Connection” and then click “Disable.”

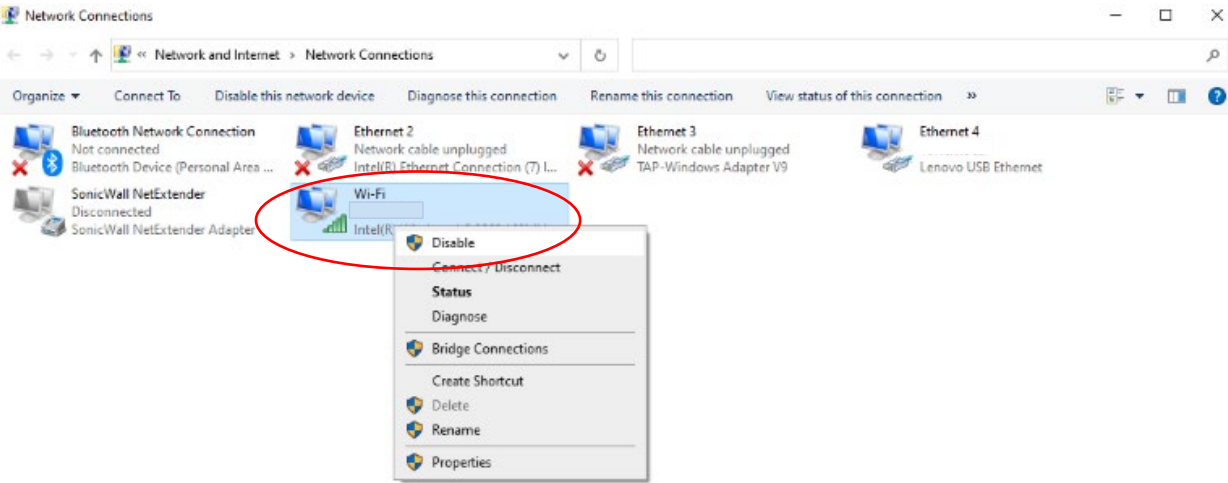

3. Right click on “Ethernet” and then select “Properties.”

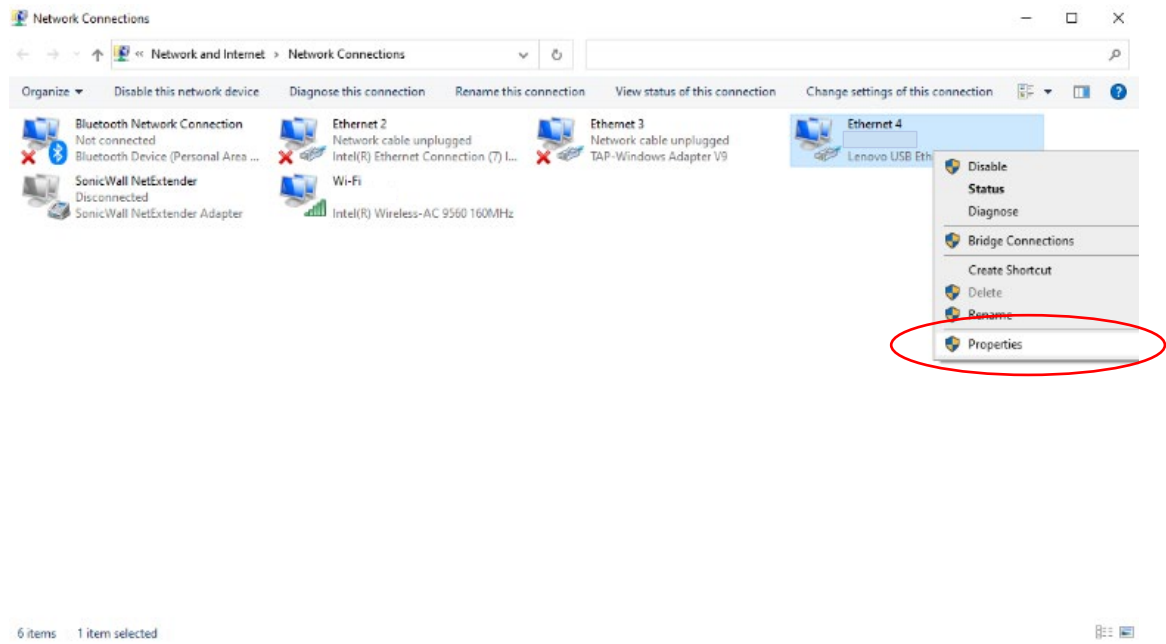

4. Click on “Internet Protocol Version 4 (TCP/IPv4)” and select “Properties.”

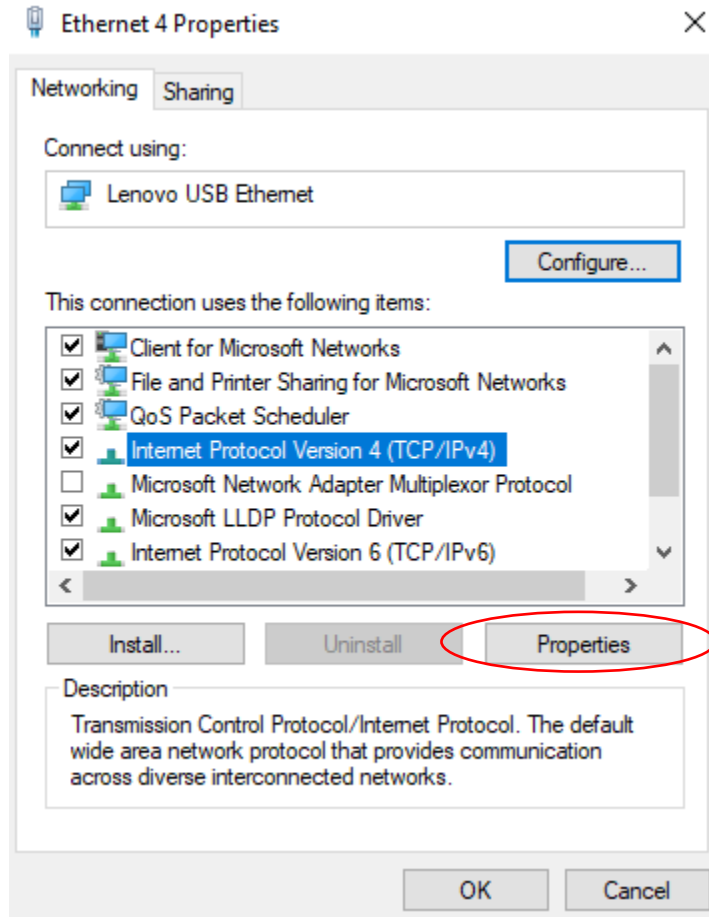

5. The below window will be displayed. Fill in the following information and then click “OK.”
 - a. Select “Use the following IP address.”
 - b. Enter the IP address you wish to use. The IP address cannot be the same as the device IP address you are connecting to. Change the last set of digits by one.
 - i. Example: If your device IP address is 169.254.202.225, then set your Static IP address to 169.254.202.226.
 - c. Enter the Subnet Mask. This is the exact same as the device you are connecting to.
 - d. Enter the Default Gateway (optional). If you do not know the Default Gateway, leave this field blank.

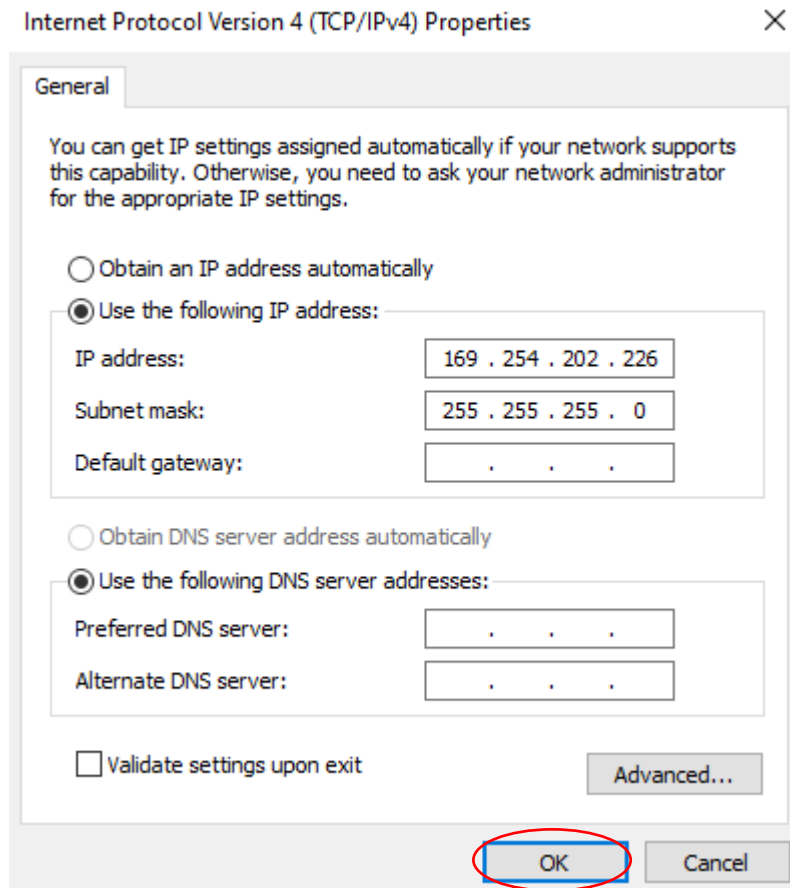

6. Once your Static IP address is set, make sure to go back to “Internet Protocol Version 4 (TCP/Pv4)” “Properties” and select “Obtain an IP address automatically.” Also, “Enable” your “Wireless Network Connection” so that you can connect back to wireless networks.

IPSetup Network Configuration Tool

IPSetup is used to configure network settings on your Sierra/TCP device such as IP Address, Mask, Gateway, and DNS Server. If enabled in your device, IPSetup uses a User Datagram Protocol (UDP) broadcast on port 20034 to identify Sierra/TCP network devices. UDP broadcasts are not forwarded by routers, so IPSetup can only be used on a LAN or direct connection. You need to run it on a PC connected to the same switch as your device.

IP Setup is commonly used for:

- Determining the DHCP assigned IP address of your device.
- Configuring the network settings of your device.

IPSetup can be downloaded from the Sierra website (Documents & Downloads). This program can run on any Windows or Linux machine under Windows emulator WINE.

Configuring the Meter with IPSetup

IPSetup/Configuration should only need to be done at initial commissioning on the customer's network.

Before you begin, please ensure the device is on the same LAN or directly connected to a PC.

To configure a device with IPSetup, follow the below instructions once opening the IPSetup tool.

1. Click on a device in the “Select a Unit” window. Note, each unit has been assigned a unique identifier code that begins with the VRTX as seen below. Also, the meter will display the current IP address upon powering up the meter.
2. Enter your configuration settings in the “NDK Settings” group. Configuration can either be set up as a static IP address assigned by your network administrator or can be set up to DHCP by setting the IP address to 0.0.0.0.
3. Once you have specified all your configuration settings, click on the “Set” button to transmit them to your device. Please Note: Besides IP, Network Mask, GateWay and DNS, do not change any other parameters, such as Uart, delay, baud rate, etc. Correct GateWay settings are necessary if you are planning to access device from the Internet or other subnets of your local network.
4. The DHCP assigned address, or static IP address, will appear in the description next to each Sierra/TCP device in the Select a Unit window.

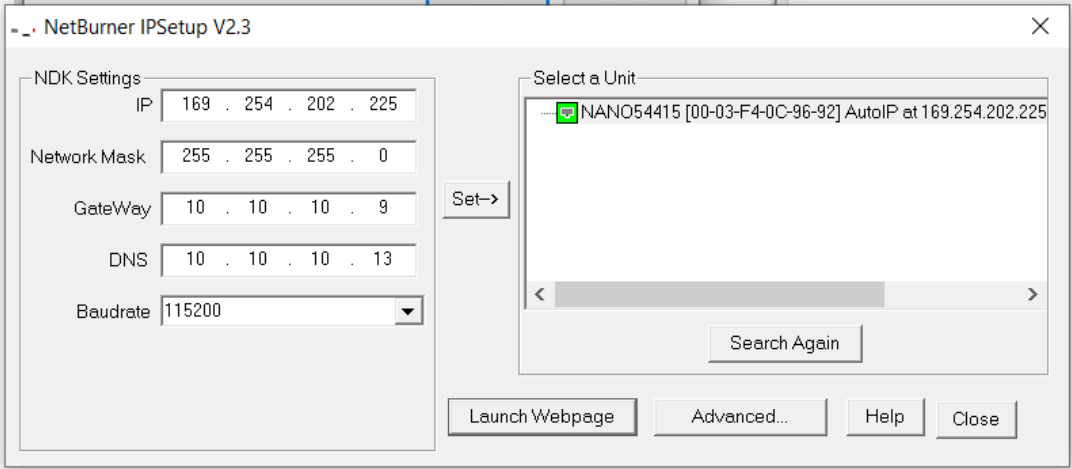

Figure 71 - IPSetup Displaying the Current IP Address

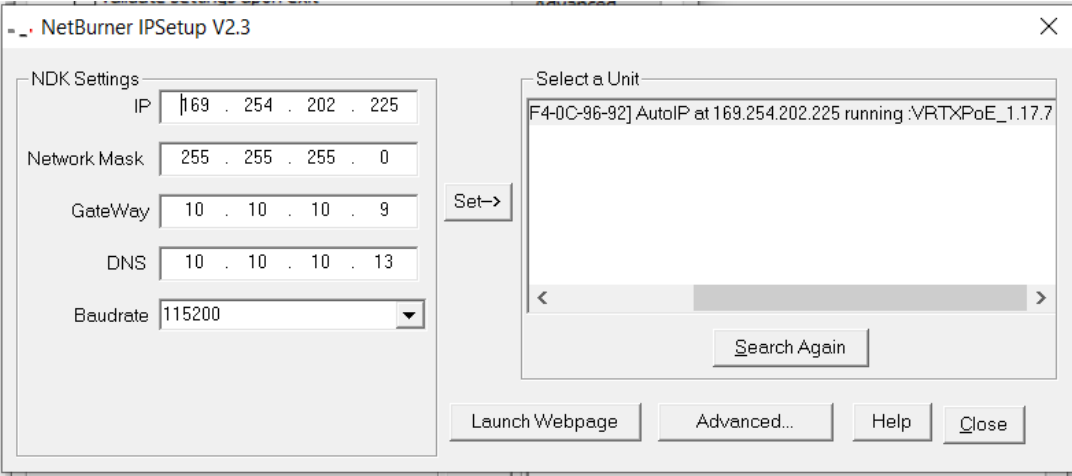

Figure 72 - IPSetup Displaying the Unique Identifier Code VRTX (NetBIOS Name)

IPSetup Does Not Display Your Sierra/TCP Device

If IPSetup does not display your device, the issue could be one of the following:

- A firewall on your PC is blocking network port number 20034. Try temporarily disabling your firewall and try again.
- If you are trying to talk to a device on the other side of a router. Check to see if the PC and Sierra/TCP devices are on the same LAN.

IPSetup FAQ

- If DHCP serve can't assign an address to the meter, it will switch to AutoIP. AutoIPs are special addresses in the range 169.254.XXX.XXX. The XXX.XXX values are randomly selected with an attempt to avoid duplication. AutoIP is used for DIRECT CONNECTION to a PC.
- IPSetup shows the name of the application as shown on Figure 70 and 71 above. The name is composed of letters VRTX and 4 last HEX digits of unit's MAC address. For example: VRTX9692 also referred to as the NetBIOS name.
- You may access the unit by typing the name in the address field of WEB browser, for example: <http://VRTX9692>. This works on Microsoft computers and may not work on Linux machines. For Linux machines it needs to have SMB protocol enabled to understand the NetBios names. You can also type the IP address of the device directly into the WEB browser, for example: 169.254.202.225
- Tip: there is linux nmblookup command, which shows IP address by NetBios name.
- It is recommended to provide a correct GateWay address. DNS is necessary only if access to the Internet is needed for the device. in case, for example, accessing Network Time Servers. It may be set as 0.0.0.0.

Meter WEB Pages

VRTXmeter has an internal WEB server providing real time measurement information and a configuration interface. It is recommended to use Google Chrome or Microsoft Edge when using the WEB pages.

The meter supports two protocols for accessing the WEB pages:

- HTTP – insecure connection to TCP port 80
- HTTPS – secure connection to configuration pages on TCP port 443.

It is possible to connect to all pages using HTTPS instead of HTTP. The assumption is that measurement data does not need to be secure, while configuration must be always encrypted.

SIERRA
<https://www.sierrainstruments.com>

Device IP:169.254.202.225 Calling IP:169.254.202.228
 F/W Revision:VRTX_1.17.7
 Device name:VRTX9692

FlowCalc
 HOME
 FLOW
 METER
 FLUID
 DIAGNOSTIC
 CONFIGURE
 DATA LOG
 STARTUP LOG

Flow Meters:
 Units: 1

Addr	Serial Number	HW	FW	Sig.Rev	OEM
1	123456	24	97.2	3.15	2 0

FlowCalc WEB Interface Rev: VRTX_1.17.7
 Configuration: PoE Generic
 Uptime: 00:03:33
 Meter RTC: 02/06/2000 02:56:34
 Networking Data: MAC:00:03:F4:0C:96:92, NETBIOS Name:VRTX9692
 My IP:169.254.202.225
 SD Free size:7,792,787,456, Options: 0x00000010
 Transmissions: 60 Errors:0

2023
 Figure 73 - Main/Home Page

Above is a Figure of the main page of the webpage with the menu selections on the left side. When the meter is initially powered up, it scans for connected meters. This version is intended for master/slave configuration with multiple meters connected to a single gateway. Normally this Slave Address selector is not used and there is always only one selection possible.

SIERRA
<https://www.sierrainstruments.com>

FlowCalc
 HOME
 FLOW
 METER
 FLUID
 DIAGNOSTIC
 CONFIGURE
 DATA LOG
 STARTUP LOG

Measured Values

Uptime	00:04:22	
Flow Values		
Mass Flow	1160.25	lb/hr
Volume Flow	2.32471	gal/min
Pressure	0	PSI (A)
Temperature 1	77.6817	°F
Fluid Density	62.2248	lbm/ft³
Flow Totalizer	256	lb
Flow Total Qty per Pulse	1000	

Figure 74 - Flow Menu

The above figure displays what values are available on the Flow Menu.

Meter Configuration		
Meter Index	2	inch
Meter K-Factor	269.159	P/ft ³
Insertion Pipe ID	1.939	inch
Insertion Base K	269.159	P/ft
Insertion Base Re	0	
Low Flow Cutoff	10	
Vortex Coefficient Ck	5	
Press Coefficient B00	-1.96404	
Press Coefficient B01	-2.39886	
Press Coefficient B02	0.196427	
Press Coefficient B10	1057.53	
Press Coefficient B11	362.476	
Press Coefficient B12	-227.993	
Press Coefficient B20	-1115.91	
Press Coefficient B21	1205.24	
Press Coefficient B22	-357.796	
Meter Diagnostic		
Faults	0	
NV Faults	0	
ADC_Counts[0]	512	
ADC_Counts[1]	238	
ADC_Counts[2]	28	
ADC_Counts[3]	4	
Analog OutCount[0]	2637	
Analog OutCount[1]	2637	
Analog OutCount[2]	2637	
Exceptions	131	

Figure 75 - Meter Menu

The above figure displays what values are available in the Meter Menu.

Fluid Configuration		
Selected Fluid Type	Real Liquid: Water	
All Fluid Parameters		
Real Liquid Type	Water	
Fluid Standard Temperature	59	°F
Fluid Standard Pressure	14.6959	psia
Fluid Normal Temperature	0	°C
Fluid Normal Pressure	101.325	kPa
Steam Standard Temperature	0	°F
Steam Standard Pressure	32.042	psia

Figure 76 - Fluid Menu

The above figure displays the values of the Fluid Menu.

SIERRA
<https://www.sierrainstruments.com>
 Device IP: 169.254.202.225
 F/W Revision: VRTX_1.17.7
 Device name: VRTX9692

FlowCalc

HOME
 FLOW
 METER
 FLUID
 DIAGNOSTIC
 CONFIGURE
 DATA LOG
 STARTUP LOG

Meter Diagnostic Details			
Shedding Frequency	1.93873	Hz	
Filter Frequency	10.1722	Hz	
Fluid Velocity	0.0943466	ft/s	
Reynolds Number	1585.68		
Temp. Compensated K-Factor	269.159	P/ft ³	
RTD1 Resistance	1098.77	Ohms	
Insertion Local K	20.549	P/ft	
Scaled Output Frequency	0	Hz	
Maximum Velocity	0.989219	ft/s	
Maximum Fluid Temperature	78.9989	°F	
Maximum Pressure	0	PSI (A)	
Amplitude (Vrms)	0.00350241	Vrms	
Electronics Temperature	84.35	°F	
Maximum Electronics Temperature	83.6887	°F	
Minimum Electronics Temperature	74.4436	°F	
Hourly Flow	0		
Obscuration	1		
Profile Factor	1.33263		
Insertion	0.9695		
Pipe Area	2.95288		
Glycol Weight %	32.3415		
External Loop mA	0	mA	

Figure 77 - Diagnostic Menu

The above figure shows the values of the Diagnostics Menu.

SIERRA
<https://www.sierrainstruments.com>
 Device IP:169.254.202.225 Calling IP:169.254.202.228
 F/W Revision:VRTX_1.17.7
 Device name:VRTX9692

FlowCalc

HOME
 FLOW
 METER
 FLUID
 DIAGNOSTIC
 CONFIGURE
 DATA LOG
 STARTUP LOG

Output	Input	Display	Alarms	Totalizer	Units
Fluid	Diagnostics	Calibration	SD Log Config	HART	System
Diagnostic Level 1	Diagnostic Level 2				

Figure 78 - Configure Menu

The above figure shows the Configure page options. You may see the following screen if this is the first time accessing the WEB page for the meter. The Username is “creator” and the Password is 16363.



Figure 79 - Configure Password Protection

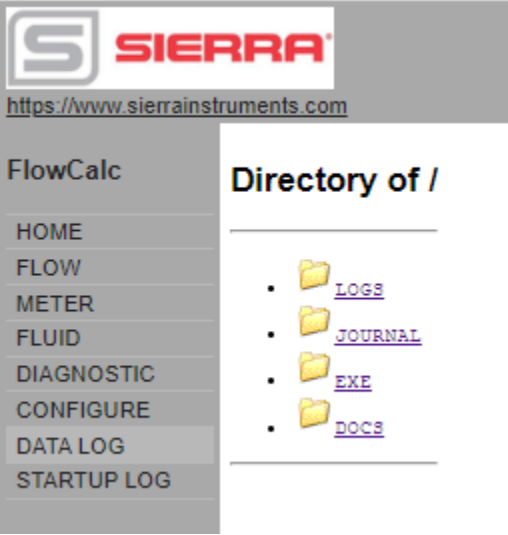

Figure 80 - Data log Menu

The above figure shows the Data Log options.

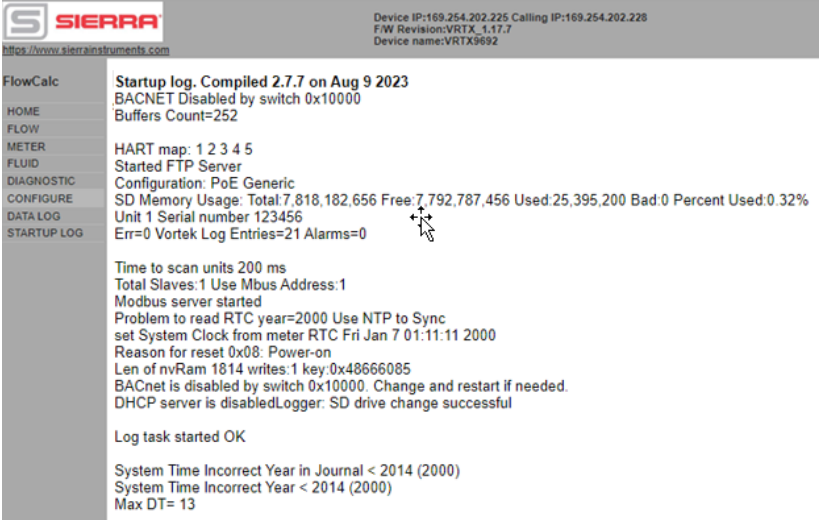

Figure 81 - Startup Log Menu

The figure above shows the Startup Log page.

WEB Configuration Interface

When access tabs in the Configure Page, you will need to enter the Username and Password.

The screenshot displays the Sierra Instruments web configuration interface. At the top, the device information is shown: Device IP: 169.254.202.225, Calling IP: 169.254.202.228, F/W Revision: VRTX_1.17.7, and Device name: VRTX9692. The URL is https://www.sierrainstruments.com. A navigation menu on the left includes HOME, FLOW, METER, FLUID, DIAGNOSTIC CONFIGURE, DATA LOG, and STARTUP LOG. The main navigation bar contains tabs for Output, Input, Display, Alarms, Totalizer, Units, Fluid, Diagnostics, Calibration, SD Log Config, HART, System, Diagnostic Level 1, and Diagnostic Level 2. The 'Output' tab is selected, showing the 'Analog Outputs Configuration' section. This section includes three 4-20 mA output configurations. Each output has a 'Measure' dropdown, '4 mA' and '20 mA' scale inputs, and a 'Time Const(s)' input. The units are specified as lb/hr, °F, and PSI (A) respectively. A 'setOutputs' button is located below the first three outputs. Below this, there is a 'Scaled Frequency' configuration with a 'Measure' dropdown (set to 'Volume Flow'), 'Lower', 'Upper', 'TC', and 'Full Scale' inputs, and a 'SET' button. At the bottom, there is a 'Bacnet Instance' input field with the value '10' and a 'SET' button.

Figure 82 - Output Tab

The screenshot displays the Sierra Instruments web configuration interface, similar to the previous one. The 'Input' tab is selected, showing the 'Analog Input Configuration' section. This section includes an 'Analog Input' configuration with a 'Measure' dropdown (set to 'Inactive'), 'Zero Scale', and 'Full Scale' inputs, and a 'SET' button.

Figure 83 - External Input Tab

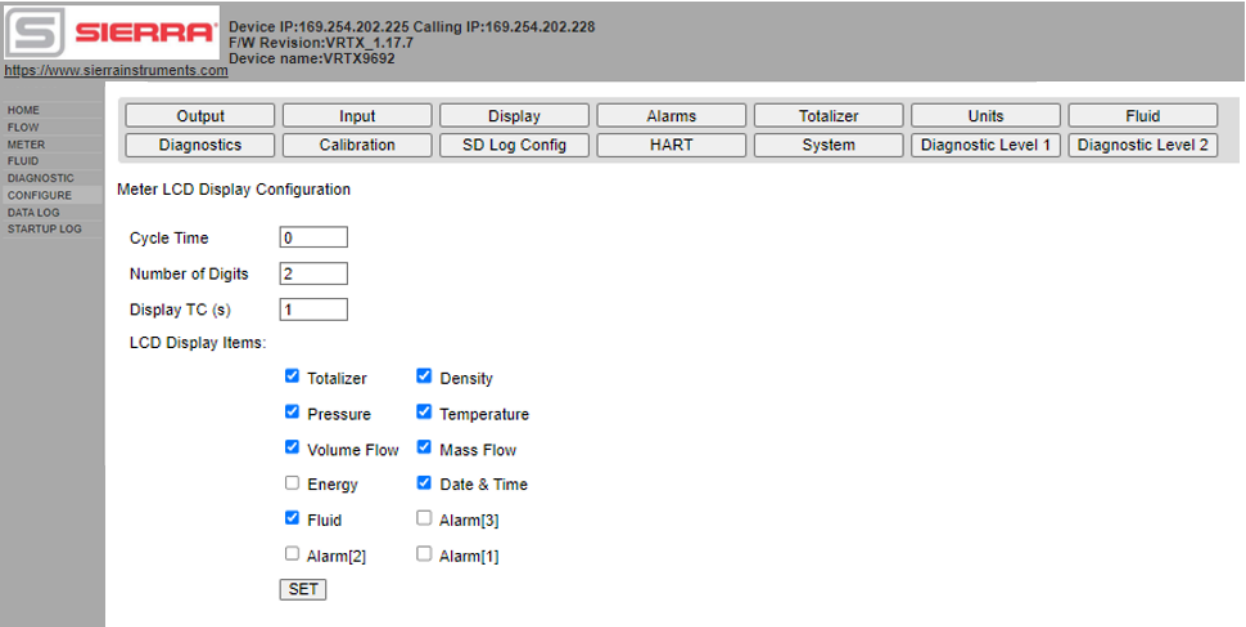

Figure 84 - Display Tab

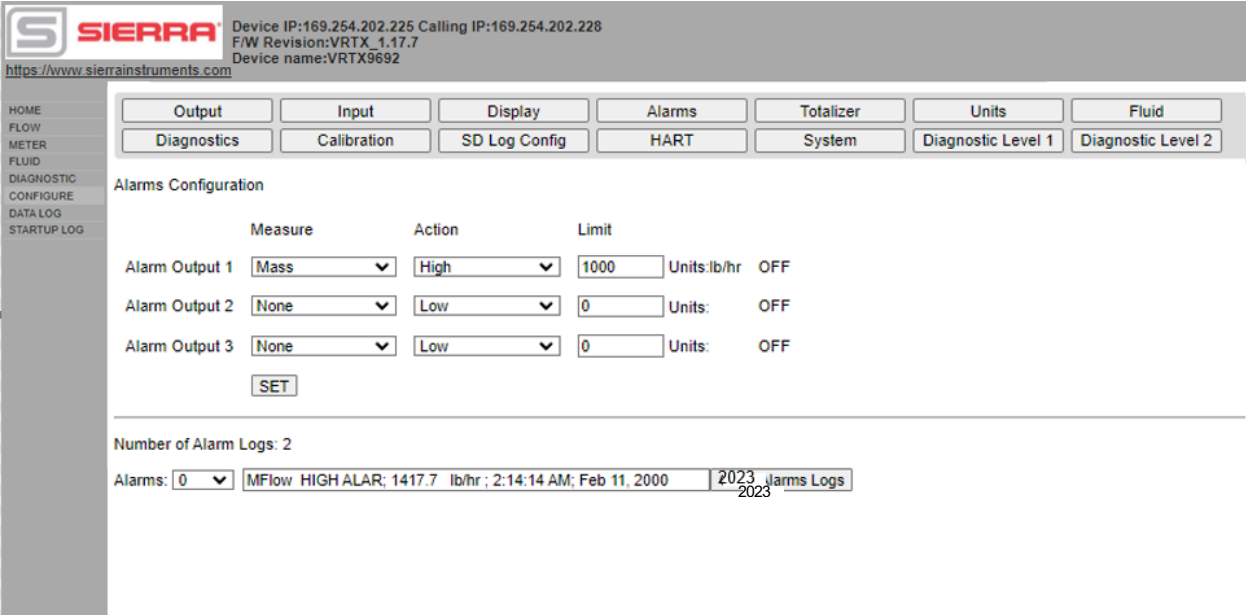

Figure 85 - Alarms Tab

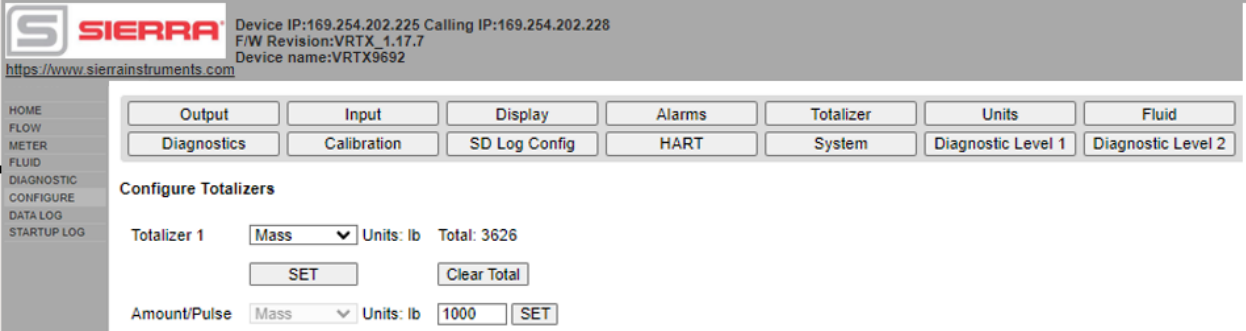

Figure 86 - Totalizer Tab

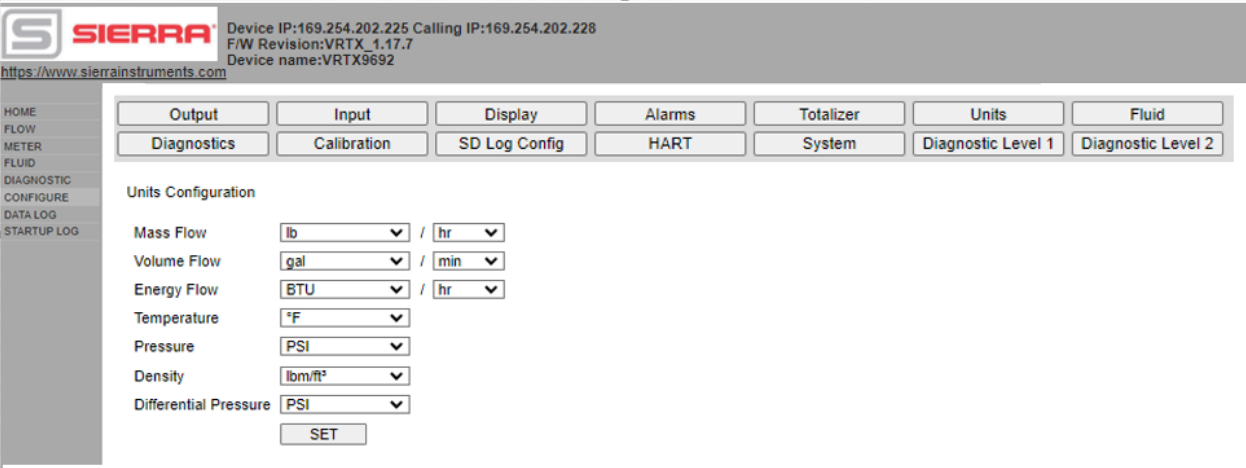

Figure 87 - Units Tab

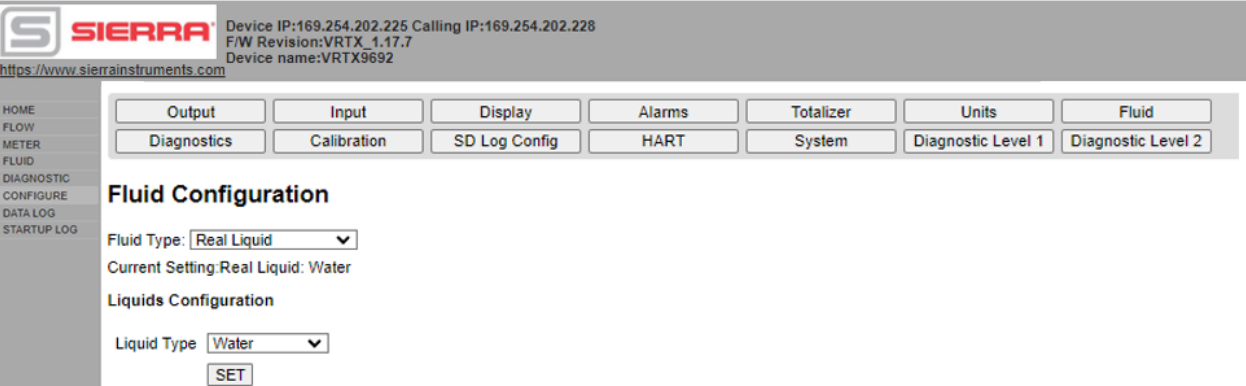

Figure 88 - Fluid Tab

SIERRA Device IP:169.254.202.225 Calling IP:169.254.202.228
 F/W Revision:VRTX_1.17.7
 Device name:VRTX9692
 https://www.sierrainstruments.com

HOME
 FLOW
 METER
 FLUID
 DIAGNOSTIC
 CONFIGURE
 DATA LOG
 STARTUP LOG

Output Input Display Alarms Totalizer Units Fluid
 Diagnostics Calibration SD Log Config HART System Diagnostic Level 1 Diagnostic Level 2

Diagnostics Menu

Zero values stop simulation.

Simulated Vor Freq (Hz)

Simulated Temp1 (°F)

Simulated Temp2 (°F)

Simulated Press (PSIA)

Highest Velocity (ft/sec)

Highest Temp (°F)

Highest Temp1 (°F)

Highest Internal Temp (°F)

Lowest Internal Temp (°F)

Highest Press (PSIA)

Number of System Logs: 23

System:

Figure 89 - Diagnostics Tab

SIERRA Device IP:169.254.202.225 Calling IP:169.254.202.228
 F/W Revision:VRTX_1.17.7
 Device name:VRTX9692
 https://www.sierrainstruments.com

HOME
 FLOW
 METER
 FLUID
 DIAGNOSTIC
 CONFIGURE
 DATA LOG
 STARTUP LOG

Output Input Display Alarms Totalizer Units Fluid
 Diagnostics Calibration SD Log Config HART System Diagnostic Level 1 Diagnostic Level 2

Calibration and Other Settings

Calibration Parameters

Meter Parameters

Misc Parameters

This Meter is Insertion Type: Use Calibration Param to set Diameter

Set Meter Clock: Month: Day: Year: H: L: Min: Sec:

TimeZone offset:

Averaging

Config Options

Avg dPt(0x04) Analog Input (0x10) BACnet (0x10000)
 Hide Quality LCD (0x1000) Hide Quality by Temp (0x2000000) PROGN (0x40000)
 Autocalc(Kr) (0x1000000) HART Temperature/Pressure (0x100000) Modbus RTU (0x20)

Figure 90 - Calibration Tab

The screenshot shows the 'SD Card Logging Configuration' tab. At the top, it displays the Sierra logo and device information: Device IP:169.254.202.225, Calling IP:169.254.202.228, F/W Revision:VRTX_1.17.7, and Device name:VRTX9692. The interface includes a navigation menu on the left with options like HOME, FLOW, METER, FLUID, DIAGNOSTIC, CONFIGURE, DATA LOG, and STARTUP LOG. The main area contains a 'Log Interval (s)' field set to '0' and an 'MB9K Config' box with the text '#offset, N-regs, format'. Below this is a grid of checkboxes for various logging items, including Flow Totalizer, Pressure, Mass Flow, Fluid Viscosity, Fluid Enthalpy1, Filter Frequency, RTD Resistance, RTotal, NRTotal, Base Re, Max Temperature, Min Internal Temperature, Temp HART, Den of water, T saturated, Mass Flow_ppl, PLR, Y1, Y3, Z_corr, Warn signature, MassFlow_av, Temperature 1, Pressure Units, Mass Flow Units, Fluid Density, Standard Ref. Density, Fluid Velocity, RTD Resistance, RTotal, NRTotal, Internal Temperature, Max Temperature1, V rms, Press HART, Den of steam, P saturated, Cd_iterated, PRR, InfTemp_av, VolFlow_av, Temperature 2, Volume Flow, Energy Flow, Density Units, Normal Ref. Density, Reynolds Number, Kc, RTotal, NRTotal, Scaled Output Frequency, Max Velocity, Hourly Flow, Den of sat steam, Den of water, Mass Flow_t, Kr_iterated, RPR, Y2, Re_iterated, XX2_simple, Temp_av, Freq_av, Temperature Units, Volume Flow Units, Energy Flow Units, Fluid Enthalpy0, Frequency, Temp Comp K Factor, RTTotal, NRTotal, Base Kc, Max Internal Temperature, Loop mA, Den of steam, Den of steam, Mass Flow_r, Kpp_iterated, X1, X3, Y_iterated, XX3_simple, Pres_av, and MB9K. A 'SET' button is located at the bottom of the configuration area.

Figure 91 - SD Log Config. Tab

The screenshot shows the 'External HART communication' tab. It features the same Sierra logo and device information as Figure 91. The navigation menu on the left is identical. The main area contains a grid of tabs: Output, Input, Display, Alarms, Totalizer, Units, Fluid, Diagnostics, Calibration, SD Log Config, HART, System, Diagnostic Level 1, and Diagnostic Level 2. The 'HART' tab is selected. Below the tabs, the text reads: 'External HART communication'. It provides instructions on the 'Format of request' and 'Format of reply'. The 'Format of request' section includes: 'unit command format_out format_in [data] (Enter)', 'where: unit 1-3 one of three HART devices', 'format: string of characters b,i,l,f,n for byte, int, long, float, length of reply', and 'Example: send command 3 - read PV, SV 1 3 0 fbfbf (Enter)'. The 'Format of reply' section includes: 'expected reply: 4.0 1 0.0 32 24.3 - where 4.0 output current, 1-units PV,PV, units SV, SV to set units=1,URV=100,ULV=0 type: 1 35 bff bff 1 100 0 (Enter)' and 'commands 12,13 and 15 do not require format.'. A 'HART Request:' label is followed by an empty text input field.

Figure 92 - HART Tab

Device IP:169.254.202.225 Calling IP:169.254.202.228
 F/W Revision:VRTX_1.17.7
 Device name:VRTX9692

Navigation Menu: HOME, FLOW, METER, FLUID, DIAGNOSTIC, CONFIGURE, DATA LOG, STARTUP LOG

System Actions:

- Reboot Gateway
- Erase Logs For year:
- Save Configuration Save File: ..
- Restore Configuration CFG file:
- Restore NV data ..
- Reset Calibration Table

Meter name: Set

Internet name: Set

Figure 93 - System Tab

Device IP:169.254.202.225 Calling IP:169.254.202.228
 F/W Revision:VRTX_1.17.7
 Device name:VRTX9692

Navigation Menu: HOME, FLOW, METER, FLUID, DIAGNOSTIC, CONFIGURE, DATA LOG, STARTUP LOG

Troubleshooting Values 1	
F (Vortex shedding frequency (Hz))	1.58213
Fi (Adaptive Filter)	7.52941
G (Gain)	0
A (Amplitude (volts rms))	0.00166508
A1	512
A2	123
A3	13
A4	2
V (Calculated average pipe velocity (ft/sec))	0.0561016
RTD1 (Resistance value of integral RTD (Ω))	1100.07
RTD2 (optional RTD resistance value (Ω))	0
CK (calculated CK at current operating conditions)	5
Lvl (threshold level)	10

Figure 94 - Diagnostic Level 1 Troubleshooting Values 1 Tab

Device IP:169.254.202.225 Calling IP:169.254.202.228
 F/W Revision:VRTX_1.17.7
 Device name:VRTX9692

Navigation Menu: HOME, FLOW, METER, FLUID, DIAGNOSTIC, CONFIGURE, DATA LOG, STARTUP LOG

Troubleshooting Values 2	
Kc	16.5917
Kb	269.159
Re (Calculated Reynolds number)	2405.34
Visc (calculated viscosity of flowing fluid (Cp))	0.891101
Enthalpy1 (BTU/hr)	0
Enthalpy2 (BTU/hr)	0
x Cnts (4-20 mA input counts)	0
Extx.xx(mA)(4-20 mA input current)	0
Sig. Rev Hardware	3
Sig. Rev Software	15
Hardware Rev	24
Software Rev	97
Firmware Minor Rev	2
Internal Temp (°F)	88.3362

Figure 95 - Diagnostics Level 1 Troubleshooting Values 2 Tab

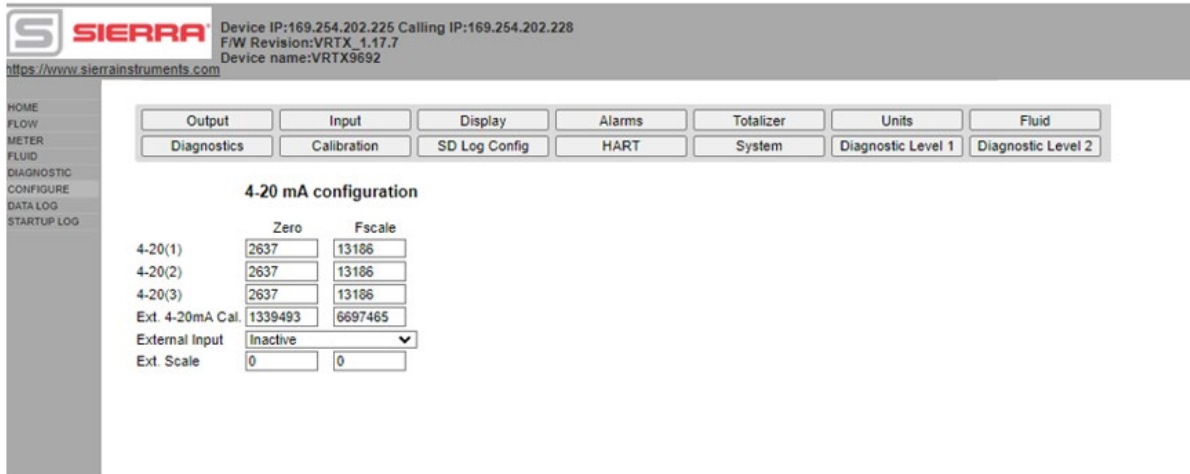

Figure 96 - Diagnostics Level 2 4-20 mA Configuration Tab

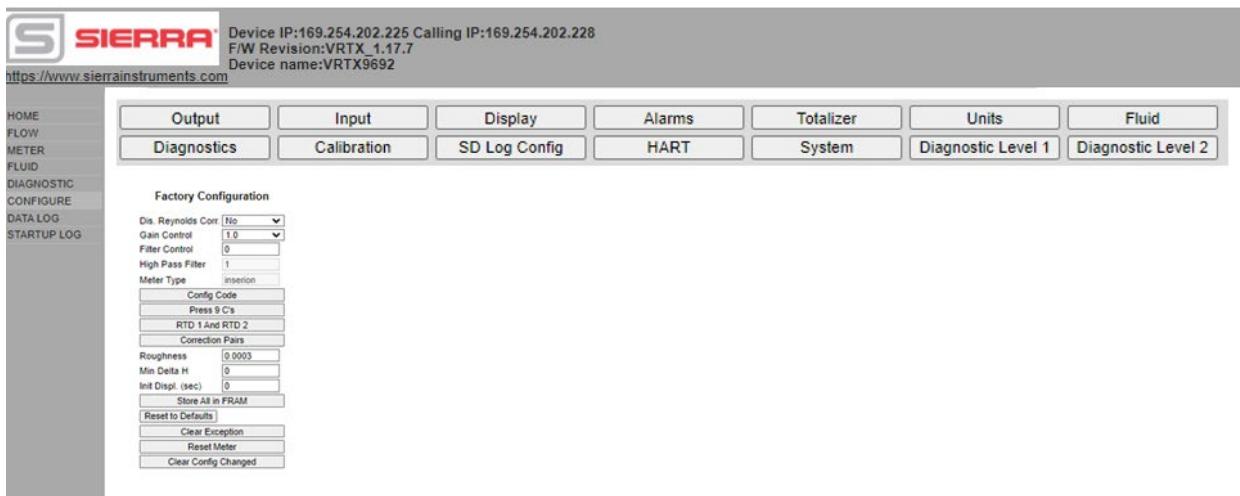

Figure 97 - Diagnostic Level 2 Factory Configuration Tab

Internet Connection to the Meter – Security Issues

Typically the meter is connected to the Local Area Network (LAN) with non-routable Private Network Address (192.168.xx.xx, 10.xx.xx.xx, 172.16-31.xx.xx). There are two options to setup the meter from the Internet:

- Connect via Virtual Private Network (VPN)
- Port Forwarding technique

In case of VPN, your home PC becomes part of your corporate network, which will allow access to all resources on the corporate LAN. Usually, your home PC is assigned an IP address from a different subnet than the meters. Therefore, the IPSetup program may not function correctly. You will need to

know the specific IP address of the meter in order to connect. Please contact your IT department about availability of VPN and connection instructions.

Second method of Port Forwarding is configuring the corporate firewall to allow you access to certain internal (LAN) IP address by mapping it to your external corporate gateway IP and port number. This is usually done by mapping. See the following for an example. Assuming your corporate gateway is 50.202.79.132 and your meter IP on LAN is 10.10.10.75.

Example of Port Forwarding

External IP 50.202.79.132 Port 8080 → mapped to → 10.10.10.75 Port 80

External IP 50.202.79.132 Port 10502 → mapped to → 10.10.10.75 Port 502

External IP 50.202.79.132 Port 10443 → mapped to → 10.10.10.75 Port 443

Please contact your IT department for configuration on corporate routers. They will need the following information on the used network port:

TCP port 80

Non-secure access to main WEB pages. Read only. Protocol HTTP. It is also possible to access meter using only secure connection via Port 443.

TCP port 443

Secure encrypted access to configuration pages. Protocol HTTPS, SSL. Encryption 128 bit – does not require Export licensing.

User/password protected (secure)

TCP port 502

Access by automation software to Modbus/TCP server. Protocol Modbus/TCP

Optional: TCP ports 20,21- Access to internal FTP server. Protocol FTP. User/password protected (insecure)

UDP port 20034

Broadcast discover protocol. Used to find units on the local Network.

It is not routable and therefore works only within the same subnet.

Used by IPSetup (discover/IP config) and AutoUpdate (flash) programs. AutoUpdate works across Ethernet switches. It uses UDP with direct address. It may be blocked by most routers.

TCP port 20034

Firmware update using TcpUpdate utility. (Not enabled in Rev 1.0 of firmware).

Corporate gateways can have additional security enhancing measures, like sourcing. Sourcing addresses only allows access from certain individual IPs or networks. If security concerns are an issue, you may limit access to the meter using encrypted protocol only: port 443, https. On special request Sierra can add special capability of Access Control List (ACL) to insecure by definition Modbus protocol. Using ACL user may define number of hosts or networks from which connection to Modbus port 502 can be accepted. Normally this function can be implemented in corporate firewall. ACL in meter may be needed when it is exposed to the Internet directly.

General information about Port Forwarding and instructions how to set up it in simple home routers available everywhere. E.g. here: <http://www.howtogeek.com/66214/how-to-forward-ports-on-your-router/>

Modbus/TCP Interface

Sierra’s TCP meter supports industry standard automation protocol Modbus/TCP. Once connected to Modbus/TCP, the addresses will be the same as our standard options.

General specifications:

Protocol	TCP
Port	502
Number of Simultaneous Connections	20
Format of 16-bit Registers	Standard MSB first (big endian)
Format of 32 Long and Float Values	Most significant word coming first (big endian)
Modbus Address	0
Supported Function Codes	3, 4, 16, 5

Modbus Utilities

We include for customer convenience two applications which may be used during integration into your automation system:

- MbusGui.exe – Windows GUI application for reading Modbus registers of the meter.
- mbus.exe – Generic DOS console application for reading Modbus/TCP registers.

These two applications are stored on SD card inside the meter. To download them click on menu link “LOG DATA” and then select directory EXE. Right click on MBUS.EXE or MBGUI.EXE link to download it to your PC.



Figure 98 - EXE Folder

BACnet/TCP Interface

All meters are configured for Modbus communications when shipped. If you are communicating with BACnet TCP/IP, make sure “BACnet (0x10000)” is selected in the “Config Options” section of the Calibration tab and the setting are saved (see below). Cycle power to the meter once this setting is saved. Note, do not change settings on the physical meter. Once connected to BACnet/TCP, the objects will be the same as our standard options.

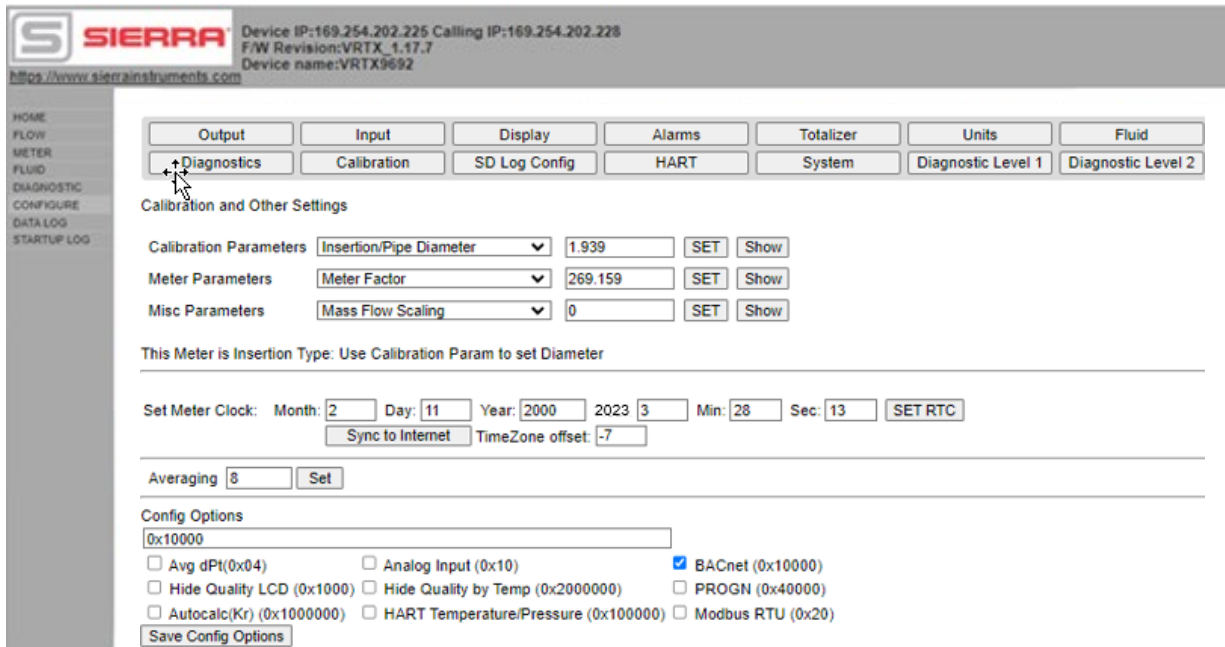

Figure 99 - Calibration Tab with BACnet Selected

Data Logging

VRTX/TCP meter has internal logging capability. The data is logged to micro SD card inside unit. The capacity of SD card may vary from 4 to 32 GB. The size of card and free space are shown on StartUp Log page. Card is formatted as FAT32 with long file name disabled. All file names are in 8.3 format. To access the log files, click menu link “DATA LOG”

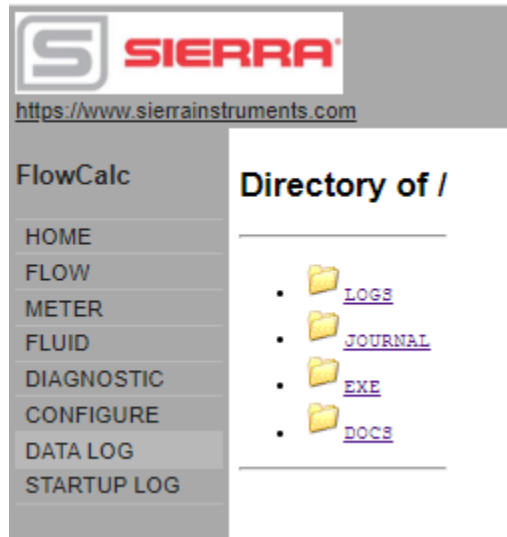

Figure 100 - Data Log Menu

The following folders are in the Data Log Menu:

- LOGS Contains Log Files
- JOURNAL Log files of unit on/off states as well as operator’s actions
- EXE Folder with several executables
- DOCS Documentation

Log files are arranged as a tree: LOGS

2019 – Year

04 – Month

22 – Day

...

04 – April 190422.CSV

190422.CSV – Daily files in Comma Separated Values text format

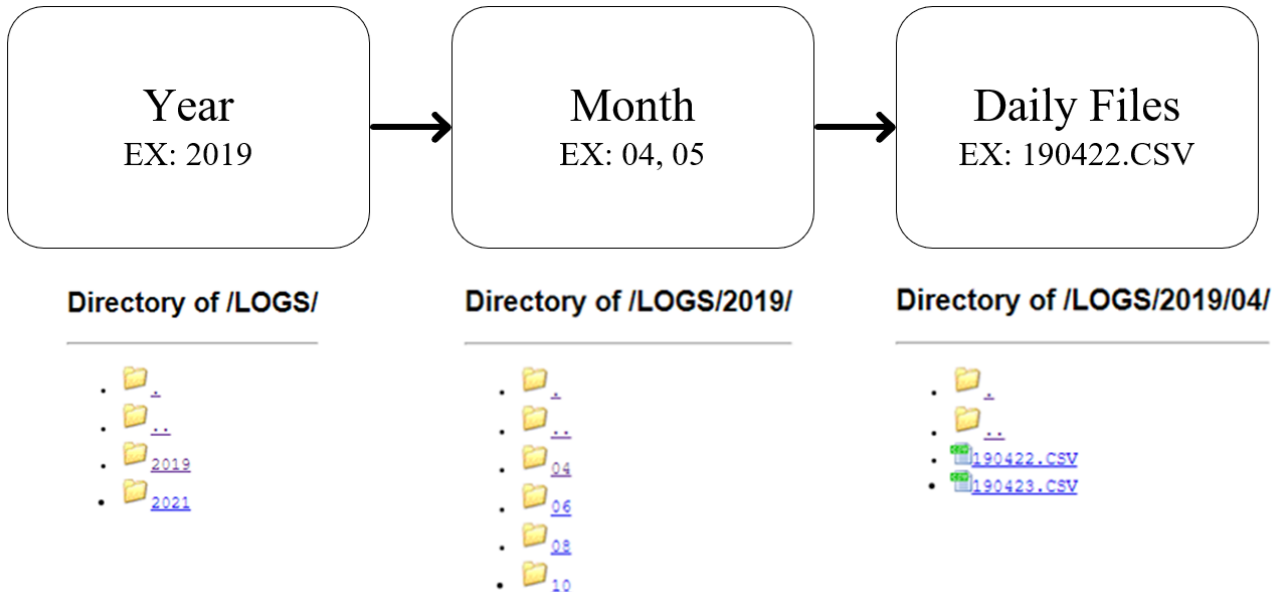

To download file to your PC, right click on the file and select “save”. You may also open it immediately by clicking on the file. It will be opened as text file or in EXCEL depending on your settings of used browser. Consult HELP of used browser to find out how to configure a default application for file extension. Normally, your browser will ask what to do with this file extension (.CSV).

In each daily file log, the first three columns in table (A, B, and C) are fixed and always present. Column A is the date, Column B is the time, and Column C is the number of seconds since the meter was restarted. All other values are configurable on the SD Log Config tab on the CONFIGURE page.

The first row in the .CSV files will be the variable name. Columns named TU, PU, VFU, MFU, and DU display Temperature, Pressure, Volume Flow, Mass Flow, and Density Units accordingly. A new header will output whenever the operator changes the list of logged items. Log interval is set on the configure page and can vary from as low as 5 seconds to whatever you choose.

	A	B	C	D	E	F	G	H	I	J	K	L	M	N	O	P	Q	R	S	T
1	Date	Time	Secs	Temp1	TU	Press	PU	VolFlow	VFU	MassFlow	MFU	FIVisc	FDens	DU	Freq	Re	Kf	IntTemp	MaxintT	hFlow
2	4/22/2019	16:05:18	176	70 F		100 PSI		0 gal/min		0 lb/hr		1.00055	62.2864	lbm/ft ³	0	0	269.159	79.9135	86.1926	0
3	4/22/2019	16:05:48	206	70 F		100 PSI		0 gal/min		0 lb/hr		1.00055	62.2864	lbm/ft ³	0	0	269.159	79.9765	86.1926	0
4	4/22/2019	16:06:19	237	70 F		100 PSI		0 gal/min		0 lb/hr		1.00055	62.2864	lbm/ft ³	0	0	269.159	80.1451	86.1926	0
5	4/22/2019	16:06:49	267	70 F		100 PSI		0 gal/min		0 lb/hr		1.00055	62.2864	lbm/ft ³	0	0	269.159	80.0761	86.1926	0
6	4/22/2019	16:07:19	297	70 F		100 PSI		0 gal/min		0 lb/hr		1.00055	62.2864	lbm/ft ³	0	0	269.159	80.2206	86.1926	0
7	4/22/2019	16:07:49	327	70 F		100 PSI		0 gal/min		0 lb/hr		1.00055	62.2864	lbm/ft ³	0	0	269.159	80.2977	86.1926	0
8	4/22/2019	16:08:20	358	70 F		100 PSI		0 gal/min		0 lb/hr		1.00055	62.2864	lbm/ft ³	0	0	269.159	80.4274	86.1926	0
9	4/22/2019	16:08:50	388	70 F		100 PSI		0 gal/min		0 lb/hr		1.00055	62.2864	lbm/ft ³	0	0	269.159	80.4164	86.1926	0
10	4/22/2019	16:09:20	418	70 F		100 PSI		0 gal/min		0 lb/hr		1.00055	62.2864	lbm/ft ³	0	0	269.159	80.5828	86.1926	0
11	4/22/2019	16:09:50	448	70 F		100 PSI		0 gal/min		0 lb/hr		1.00055	62.2864	lbm/ft ³	0	0	269.159	80.5992	86.1926	0
12	4/22/2019	16:10:20	478	70 F		100 PSI		0 gal/min		0 lb/hr		1.00055	62.2864	lbm/ft ³	0	0	269.159	80.5499	86.1926	0
13	4/22/2019	16:10:50	508	70 F		100 PSI		0 gal/min		0 lb/hr		1.00055	62.2864	lbm/ft ³	0	0	269.159	80.5647	86.1926	0
14	4/22/2019	16:11:21	539	70 F		100 PSI		0 gal/min		0 lb/hr		1.00055	62.2864	lbm/ft ³	0	0	269.159	80.6835	86.1926	0
15	4/22/2019	16:11:51	569	70 F		100 PSI		0 gal/min		0 lb/hr		1.00055	62.2864	lbm/ft ³	0	0	269.159	80.6758	86.1926	0
16	4/22/2019	16:12:21	599	70 F		100 PSI		0 gal/min		0 lb/hr		1.00055	62.2864	lbm/ft ³	0	0	269.159	80.7113	86.1926	0
17	4/22/2019	16:12:51	629	70 F		100 PSI		0 gal/min		0 lb/hr		1.00055	62.2864	lbm/ft ³	0	0	269.159	80.6583	86.1926	0
18	4/22/2019	16:13:22	660	70 F		100 PSI		0 gal/min		0 lb/hr		1.00055	62.2864	lbm/ft ³	0	0	269.159	80.7283	86.1926	0
19	4/22/2019	16:13:52	690	70 F		100 PSI		0 gal/min		0 lb/hr		1.00055	62.2864	lbm/ft ³	0	0	269.159	80.7414	86.1926	0
20	4/22/2019	16:14:22	720	70 F		100 PSI		0 gal/min		0 lb/hr		1.00055	62.2864	lbm/ft ³	0	0	269.159	80.76	86.1926	0
21	4/22/2019	16:14:52	750	70 F		100 PSI		0 gal/min		0 lb/hr		1.00055	62.2864	lbm/ft ³	0	0	269.159	80.8159	86.1926	0
22	4/22/2019	16:15:22	780	70 F		100 PSI		0 gal/min		0 lb/hr		1.00055	62.2864	lbm/ft ³	0	0	269.159	80.7852	86.1926	0
23	4/22/2019	16:15:52	810	70 F		100 PSI		0 gal/min		0 lb/hr		1.00055	62.2864	lbm/ft ³	0	0	269.159	80.7475	86.1926	0
24	4/22/2019	16:16:23	841	70 F		100 PSI		0 gal/min		0 lb/hr		1.00055	62.2864	lbm/ft ³	0	0	269.159	80.8728	86.1926	0
25	4/22/2019	16:16:53	871	70 F		100 PSI		0 gal/min		0 lb/hr		1.00055	62.2864	lbm/ft ³	0	0	269.159	80.9165	86.1926	0
26	4/22/2019	16:17:23	901	70 F		100 PSI		0 gal/min		0 lb/hr		1.00055	62.2864	lbm/ft ³	0	0	269.159	80.8006	86.1926	0
27	4/22/2019	16:17:53	931	70 F		100 PSI		0 gal/min		0 lb/hr		1.00055	62.2864	lbm/ft ³	0	0	269.159	80.9023	86.1926	0

Figure 101 - EXCEL Example

The SD Log Config tab has the following variables available to log. Just select desired items and click SET button at the bottom of the page.

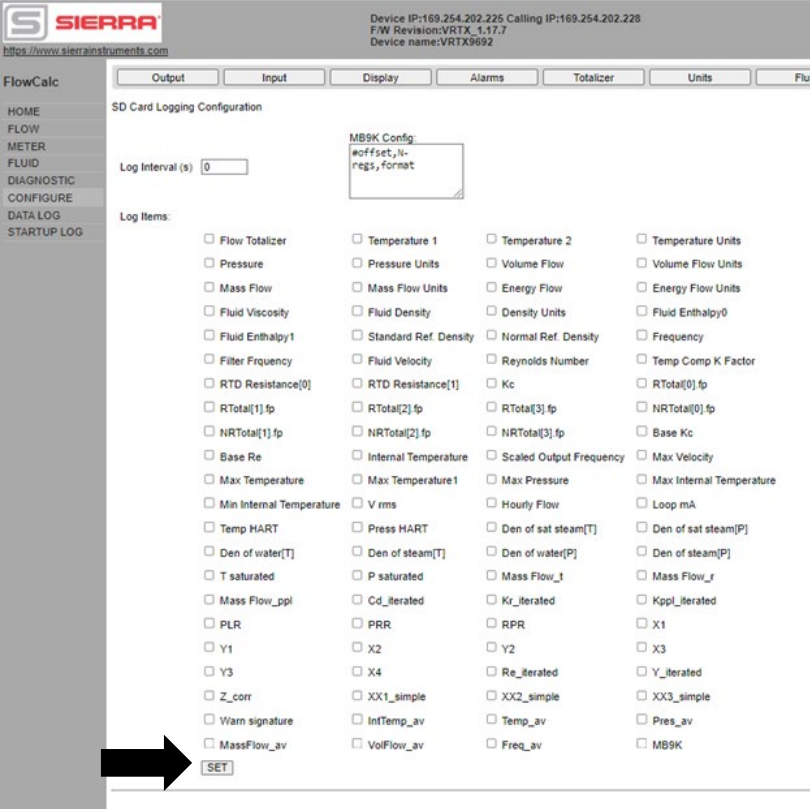

Figure 102 - SD Log Configuration Tab

Updating the Firmware

VORTEX meter firmware can be updated on-line. For that there are two applications:

- AutoUpdate – Standard update utility using UDP protocol. Local network only.
- TcpUpdate – Update utility using TCP protocol allowing access from other networks.

In revision 1.0 of VORTEX/TCP TcpUpdate is disabled. AutoUpdate should always be used.

The AutoUpdate application can be downloaded from EXE directory on SD file system of the unit.

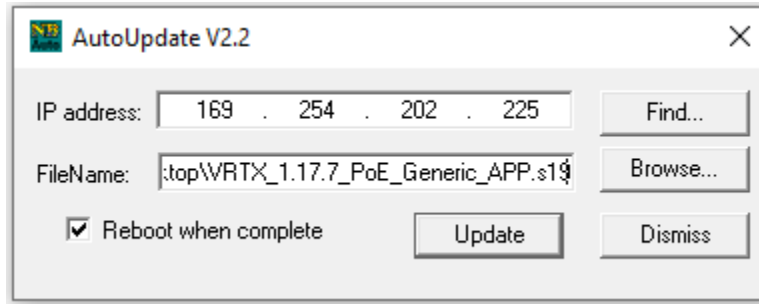

Figure 103 - AutoUpdate

Enter the IP address of your meter (or find meter on the local network). Browse for provided by Sierra application file in xxx_APP.s19 format. Click update and then your firmware will be updated.

Update with TcpUpdate is the same, except FIND may not work across routers/switches.

Chapter 5 Troubleshooting and Repair



Warning! Before attempting any flow meter repair, verify that the line is not pressurized. Always remove main power before disassembling any part of the mass flow meter

Hidden Diagnostics Menus

The menus shown on the following page can be accessed using the password 16363, then moving to the display that reads “Diagnostics Menu” and pressing ENTER (rather than one of the arrow keys).

Use the right arrow key to move to the second level. Press EXIT to move from the second level back to the first, press EXIT while in the first level to return to the setup menus.



Caution! password 16363 will allow full access to the configuration and should be used carefully to avoid changes that can adversely alter the function of the meter.

Each of the menus on the following page will first be defined followed by specific troubleshooting steps.

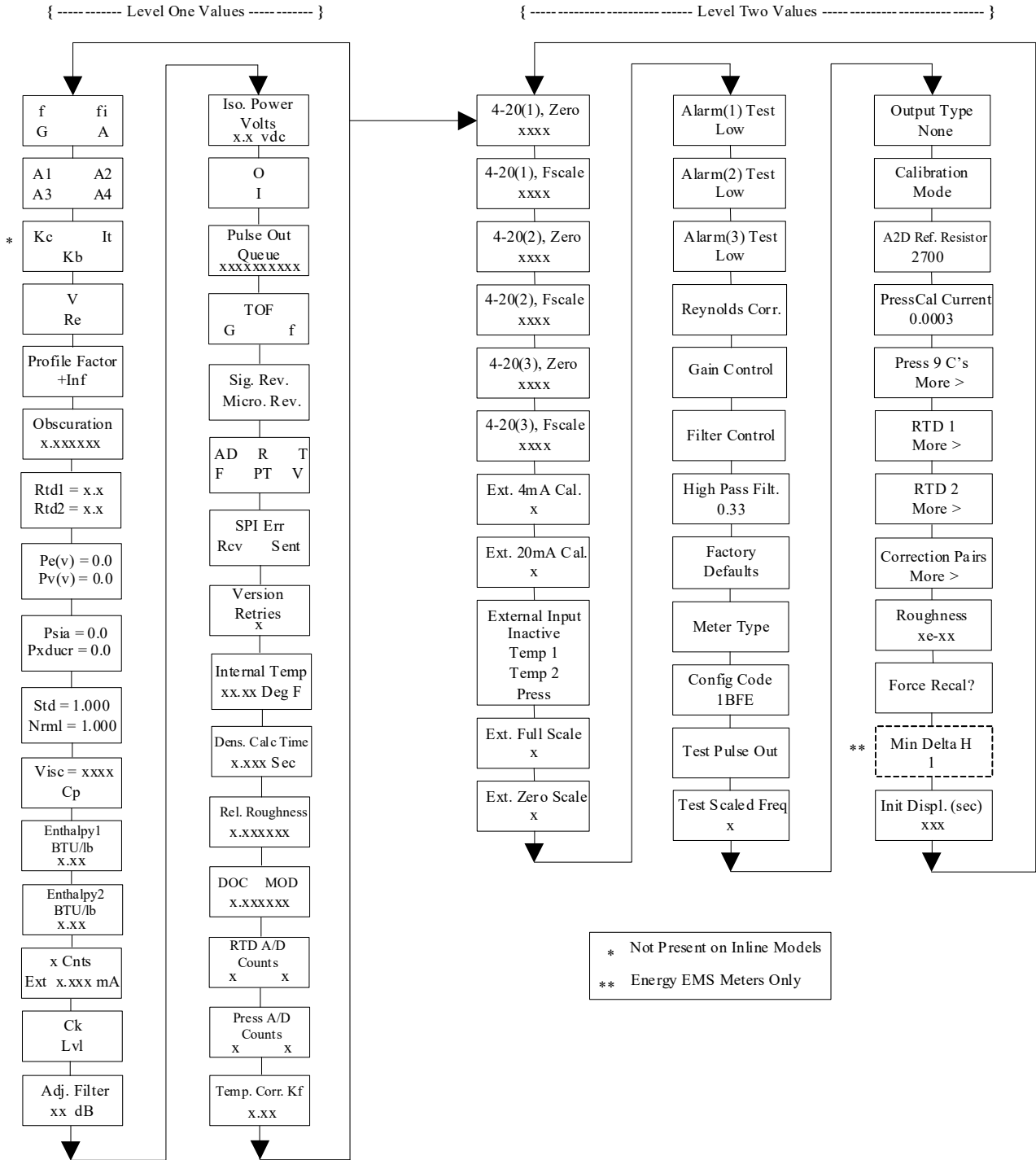

Level One Hidden Diagnostics Values

- **f** = Vortex shedding frequency (Hz).
- **fi** = Adaptive filter – should be approximately 25% higher than the vortex shedding frequency, this is a low-pass filter. If the meter is using the Filter Control (see below) in the manual mode, **fi** will be displayed as **fm**.
- **G** = Gain (applied to vortex signal amplitude). Gain defaults to 1.0 and can be changed using the Gain Control (see below).
- **A** = Amplitude of vortex signal in Volts rms.
- **A1, A2, A3, A4** = A/D counts representing the vortex signal amplitude. Each stage (A1-A4) cannot exceed 512. Beginning with stage A1, the A/D counts increase as the flow increases. When stage A1 reaches 512, it will shift to stage A2. This will continue as the flow rate increases until all 4 stages read 512 at high flow rates. Higher flow rates (stronger signal strength) will result in more stages reading 512.
- **Kc, It, Kb** = Profile equation (factory use only). Model 241S only.
- **V** = Calculated average pipe velocity (ft/sec).
- **Re** = Calculated Reynolds number.
- **Profile Factor** = Factory use only.
- **Obscuration** = Factory use only.
- **RTD1** = Resistance value of integral RTD in ohms.
- **RTD2** = Optional RTD resistance value in ohms.
- **Pe(v)** = Pressure transducer excitation voltage.
- **Pv(v)** = Pressure transducer sense voltage.
- **Psia** = Pressure value of integral transducer in psia.
- **Pxducr** = Pressure value of integral transducer in pressure unit.
- **Std** = Density of fluid at standard conditions.
- **Nrml** = Density of fluid at normal conditions.
- **Viscosity** = Calculated viscosity of flowing fluid.
- **Enthalpy1 BTU/lb** = Factory use only.
- **Enthalpy2 BTU/lb** = Factory use only.
- **x Cnts** = A/D counts from the external 4-20 mA input.
- **Ext x.xxx mA** = Calculated external 4-20 mA input from the digital counts.
- **Ck** = Calculated Ck at current operating conditions. Ck is a variable in the equation that relates signal strength, density, and velocity for a given application. It is used for noise rejection purposes. Ck directly controls the fi value (see above). If the Ck is set too low (in the calibration menu), then the fi value will be too low and the vortex signal will be rejected resulting in zero flow rate being displayed. The calculated Ck value in this menu can be compared to the actual Ck setting in the calibration menu to help determine if the Ck setting is correct.
- **Lvl** = Threshold level. If the Low Flow Cutoff in the calibration menu is set above this value, the meter will read zero flow. The Lvl level can be checked at no flow. At no flow, the Lvl must be below the Low Flow Cutoff setting or the meter will have an output at no flow.

- **Adj. Filter** = Adjustable filter. Displays the filtering in decibels. Normally reads zero. If this value is consistently -5 or -10, for example, the Ck or density setting may be wrong.
- **Iso. Power Volts** = Nominally 2.7 VDC, if less than this check the flow meter input power.
- **O, I** = Factory use only.
- **Pulse Out Queue** = Pulse output queue. This value will accumulate if the totalizer (unit)/pulse is set too low. Pulses will accumulate faster than the pulse output hardware can function. The queue will allow the pulses to “catch up” later if the flow rate decreases, causing stored pulses to output not in real time. A better practice is to slow down the totalizer pulse by increasing the value in the (unit)/pulse setting in the totalizer menu.
- **TOF, G, f** = Factory use only.
- **Sig. Rev** = Signal board hardware and firmware revision.
- **Miro Rev** = Microprocessor board hardware and firmware revision.
- **AD, R, T, F, PT, V** = Factory use only.
- **SPI Err, Rcv, Sent** = Factory use only.
- **Version Retries** = Factory use only.
- **Internal Temperature** = Electronics temperature.
- **Dens. Calc Time** = Factory use only.
- **Rel. Roughness** = Factory use only.
- **DOC, MOD** = Factory use only.
- **RTD A/D Counts** = Factory use only.
- **Press A/D Counts** = Factory use only.
- **Temp. Corr. Kf** = Factory use only.

Level Two Hidden Diagnostics Values

- **4-20(1) Zero** = Analog counts to calibrate zero on analog output 1.
- **4-20(1) FScale** = Analog counts to cal. full scale on analog output 1.
- **4-20(2) Zero** = Analog counts to calibrate zero on analog output 2.
- **4-20(2) FScale** = Analog counts to cal. full scale on analog output 2.
- **4-20(3) Zero** = Analog counts to calibrate zero on analog output 3.
- **4-20(3) FScale** = Analog counts to cal. full scale on analog output 3.
- **Ext. 4 mA Cal.** = Enter 0 for auto calibration or enter factory supplied A/D counts. Note: You must connect a known 4.00 mA input if you are going to calibrate the unit.
- **Ext. 20 mA Cal.** = Enter 0 for auto calibration or enter factory supplied A/D counts. Note: You must connect a known 20.00 mA input if you are going to calibrate the unit.
- **External Input** = Enter what the external 4-20 mA input represents, i.e. Temperature 1, Temperature 2, or Pressure. The meter will use this for its internal calculations.
- **Ext. Full Scale** = Enter the full scale units that correlate to the 20 mA point. Note: It must be in the units for the selected input type such as Deg F, Deg C, PSIA, Bar A, etc.

- **Ext. Zero Scale** = Same as above but for the 4 mA point.
- **Alarm (1) Test** = Used as a test to verify that the alarm circuit is functioning. When low is selected the alarm will initiate a low alarm on the output. When High is selected it will give a high alarm on the output.
- **Alarm (2) Test** = Used as a test to verify that the alarm circuit is functioning. When low is selected the alarm will initiate a low alarm on the output. When High is selected it will give a high alarm on the output.
- **Alarm (3) Test** = Used as a test to verify that the alarm circuit is functioning. When low is selected the alarm will initiate a low alarm on the output. When High is selected it will give a high alarm on the output.
- **Reynolds Corr.** = Reynolds number correction for the flow profile. Set to Enable for 241S insertion and set to Disable for 240S inline.
- **Gain Control** = Manual gain control (factory use only). Leave set at 1.
- **Filter control** = Manual filter control. This value can be changed to any number to force the f_i value to a constant. A value of zero activates the automatic filter control which sets f_i at a level that floats above the f value.
- **High Pass Filter** = Filter setting – Factory use only
- **Factory Defaults** = Reset factory defaults. If you change this to Factory and press Enter, all the factory configuration is lost and you must reconfigure the entire program. Consult the factory before performing this process, it is required only in very rare cases.
- **Meter Type** = Insertion (241S) or Inline (240S) meter.
- **Config Code** = Factory use only.
- **Test Pulse Out** = Force totalizer pulse. Set to Yes and press enter to send one pulse. Very useful to test totalizer counting equipment.
- **Test Scaled Freq** = Enter a frequency value in order to test the scaled frequency output. Return to 0 to stop the test.
- **Output Type** = Factory use only.
- **Calibration Mode** = Factory use only.
- **A2D Ref. Resistor** = Factory use only.
- **Pressure Cal Current** = Calibration value for the electronics and pressure transducer combination. Consult Factory for value.
- **Pressure 9 C's** = Nine pressure coefficients unique to the pressure transducer. Use the RIGHT ARROW to access all nine coefficients.
 - **Press. Max psi** = Based on installed sensor.
 - **Press. Min psi** = 0 psia
- **RTD1** = Press the RIGHT ARROW to access:
 - **Ro** = RTD resistance at 0°C (1000 ohms).
 - **A** = RTD coefficient A (.0039083).
 - **B** = RTD coefficient B (-5.775e-07).
 - **RTD1 Max Deg. F** = 500
 - **RTD1 Min Deg. F** = -330

- **RTD2** = Second RTD configuration, for special applications only.
- **Correction Pairs**
 - **ft3/sec** (1 through 10)
 - **%Dev.** (1 through 10)
- **Roughness** = Factory use only.
- **Force Recal?** = Factory use only.
- **Min. Delta H** – Energy EMS meters only. Sets the deadband for totalization to begin. Must be greater than this number (1 default) to initiate the totalizer.
Init Displ. (sec) = Enter a value in seconds to initialize the display every xxx seconds. Enter a value of 0 to disable initializing the display.

Analog Output Calibration

To check the 4–20 mA circuit, connect a DVM in series with the output loop. Select zero or full scale (from the second level of the hidden diagnostics) and then actuate the enter key twice. This action will cause the meter to output its 4 mA or 20 mA condition. If the DVM indicates a current greater than ± 0.006 mA from 4 or 20, adjust the setting up or down until the output is calibrated.

Note: these settings are not for adjusting the output zero and span to match a flow range, that function is located in the Output Menu.

Display Contrast Adjustment

The flow meter display contrast is set at the factory but if the display characters appear too dark or too light proceed as follows:

1. Hold down the “Exit” button on the front panel for 5 to 10 seconds. “Setting Contrast” will appear.
2. Push the “Up” arrow to darken the display or the “Down” arrow to lighten it.
3. Push the “Enter” button to save the contrast setting.

Troubleshooting the Flow Meter



Warning! Before attempting any flow meter repair, verify that the line is not pressurized. Always remove main power before disassembling any part of the mass flow meter. Use hazardous area precautions if applicable. Static sensitive electronics - use electro-static discharge precautions.

First Check Items:

- Installation Direction Correct
- Installation Depth Correct (Insertion style meter)
- Power and Wiring Correct
- Application Fluid Correct

Please record what the fluid is _____

- Meter Range Correct for the Application
- Meter Configuration Correct
- Describe Installation Geometry i.e. upstream diameters, valve position, downstream diameters, etc.

Record Values:

Record the following values from the Run Menu with the meter installed in order to determine the operating state of the flow meter:

	With Flow	With No Flow (if possible)
Flow =		
Temperature =		
Pressure =		
Density =		
Error Messages? =		

Record the following values from the Hidden Diagnostics Menu with the meter installed: (Use password 16363 to access)

	With Flow	With No Flow (if possible)
f =		
fi =		
A =		
A1 =		
A2 =		
A3 =		
A4 =		
V =		

Record values - Hidden Diagnostics Menu continued:

	With Flow	With No Flow (if possible)
Ck =		
Lvl =		
Adj. Filter =		
Iso. Power Volts =		
Config. Code =		

Note: The Config. Code is in Hidden Diagnostics Level 2

Record the following values from the Calibration Menu.

Meter Size / Pipe ID =	
Meter Factor =	
Vortex Coef Ck =	
Low Flow Cutoff =	
Serial Number =	

Determine the Fault

Symptom: Output at No Flow

If the Low Flow Cutoff is less than Lvl and there is an output at no flow, then the Low Flow Cutoff is set too low. At no flow, go to the first level of the Hidden Diagnostics Menu and record the Lvl value. The Low Flow Cutoff must be set above the Lvl value. Increase the Low Flow Cutoff until the meter no longer gives an output at no flow.

Example: No flow and Lvl = 25

Set the Low Flow Cutoff in the Calibration Menu to approximately 28 and the meter will no longer read a flow rate at no flow.

Symptom: Erratic Output

The flow rate may be too low, just at the cutoff of the meter range, and the flow cycles above and below the cutoff causing an erratic output. Consult the factory if necessary to confirm the meter range based on current operating conditions.

Mechanical installation may be incorrect. Verify the straight run is adequate as described in Chapter 2. For inline meters, make sure the meter is not installed backwards and there are no gaskets protruding into the flow stream. For insertion meters, verify the insertion depth and flow direction.

The meter may be reacting to actual changes in the flow stream. The displayed values can be smoothed using the time constant in the Display Menu. The analog outputs can be smoothed using the time constant in the Output Menu. Increasing the time constant will average out the flow rate data over a longer period of time, resulting in a smoother reading.

Symptom: No Output

The Vortex Coefficient Ck may need to be adjusted. The Ck is a value in the equation used to determine if a frequency represents a valid vortex signal given the fluid density and signal amplitude. In practice, the Ck value controls the adaptive filter, fi, setting. During flow, view the f and fi values in the first level of the Hidden Diagnostics. The fi value should be approximately 10-20 % higher than the f value. The Calibration Menu Ck and the Hidden Diagnostics Ck should be close to the same value. If the Calibration Menu Ck value is significantly lower than the Hidden Diagnostics Ck value, this may cause the vortex signal to be rejected resulting in zero flow being displayed. If you raise the Ck setting in the Calibration Menu, then the fi value will increase and the Ck values should be closer to each other. The fi is a low pass filter, so by increasing it or lowering it, you can alter the range of frequencies that the meter will accept. If the vortex signal is strong, the fi value should increase to a large number.

For remote mounted electronics, carefully check all the wiring connections in the remote mount junction box. There are 18 connections that must be correct, verify each color (black and red), shield, and wire number.

Turn on the pressure and temperature display in the Display Menu and verify that the pressure and temperature are correct.

Using ESD precautions and hazardous area precautions, remove the electronics enclosure window cover. Disconnect all sensors and gently wiggle on sensor wires. In some cases, loose wires can affect readings. If wires pop out, simply place the crimped metal end back into the white Molex connectors. There will be a small click once the sensor wire is correctly in place. Cycle power and note measurements.

Symptom: Meter Displays Temperature Fault

The recorded RTD values are resistance values that should correspond to the process temperature. 1000 ohm platinum RTD's are used. Please consult a resistance versus temperature table to check the temperature value. They are approximately 1080 ohms at room temperature. If the temperature is in error, the RTD may be checked as described in the Check Sensors section below. RTD2 is used for energy flow meter models.

Symptom: Meter Displays Pressure Fault

If the recorded value for pressure (Pe(V) or Pv(V)) are in error or the meter displays a pressure faults, the pressure sensor may be checked as described in the Check Sensors section below.

Check Sensors

Using ESD precautions and hazardous area precautions, remove the electronics enclosure window cover. Disconnect the sensor connectors from the electronic stack or remote feedthrough board. Refer to Figures 103 or 104.

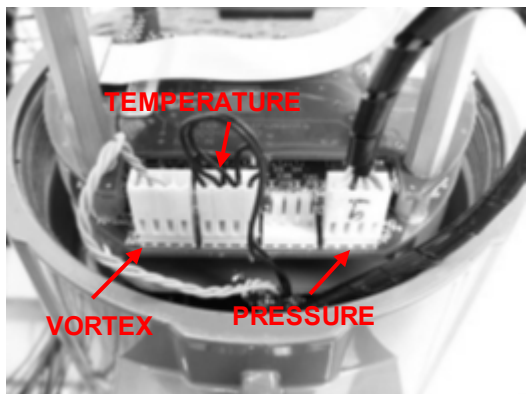

Figure 104 - Electronic Stack Sensor Connections (Local Meters)

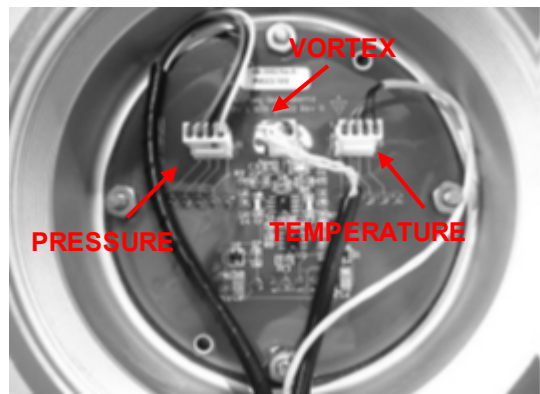

Figure 105 - Remote Feedthrough Board Sensor Connections (Remote Meters)

Check Vortex Sensor:

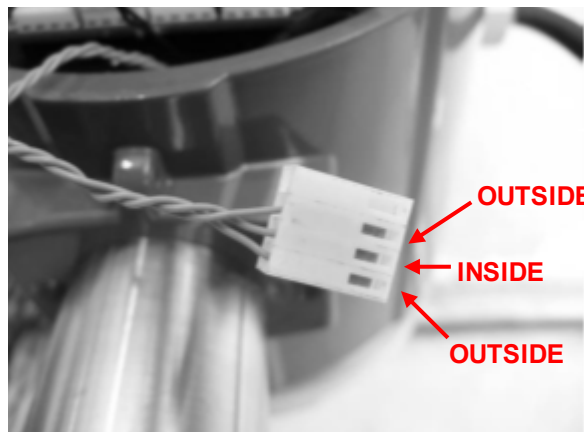

Figure 106 - Vortex Sensor Connector

Measure the resistance from each outside pin to the meter ground. Each should be open.

Measure the resistance from the center pin to the meter ground. This should be grounded to the meter.

With the sensor still disconnected, go to the first level of the Hidden Diagnostics and display the vortex shedding frequency, f . Hold a finger on the three exposed pins on the analog board. The meter should read electrical noise, 60 Hz for example. If all readings are correct, reinstall the vortex sensor wires.

Check Temperature Sensor:

Note, if you have a High Temperature meter, the temperature sensor wires will be orange.

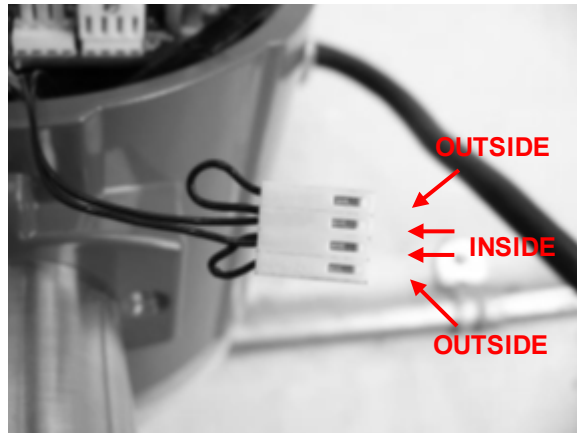

Figure 107 - Temperature Sensor Connector

Measure the resistance across the outside pins of the temperature sensor connector. It should read approximately 1080 ohms at room temperature (higher resistance at higher temperatures).

Measure the resistance across the inside pins, they should read the same.

Measure the resistance from one of the outside pins to case ground then from one of the inside pins to case ground. They should read open.

If all readings are correct, reinstall the temperature sensor wires. Go to the first level of the Hidden Diagnostics and check the resistance of the RTD1. It should be about 1080 ohms at room temperature.

Check Pressure Sensor:

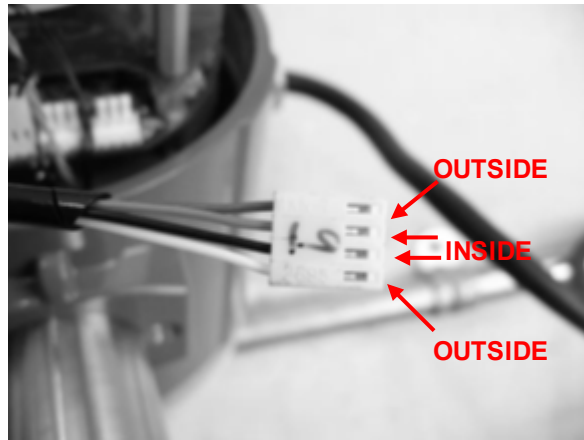

Figure 108 - Pressure Sensor Connector

Measure the resistance across the outside pins of the pressure sensor connector, then across the inside pins. Both readings should be approximately 4300-4800 ohms.

Measure the resistance from one of the outside pins to case ground then from one of the inside pins to case ground. They should read open.

If all readings are correct, reinstall the temperature sensor wires. Go to the first level of the hidden diagnostics and record the $P_e(V)$ and $P_v(V)$ values and consult the factory with findings.

Electronics Assembly Replacement (All Meters)

The electronics boards are electrostatically sensitive. Wear a grounding wrist strap and make sure to observe proper handling precautions required for static-sensitive components.



Warning!

Before attempting any flow meter repair, verify that the line is not pressurized. Always remove main power before disassembling any part of the mass flow meter.

1. Turn off power to the unit.
2. Locate and loosen the small set screw which locks the larger enclosure cover in place. Unscrew the cover to expose the electronics stack.
3. Locate the sensor harnesses which come up from the neck of the flow meter and attaches to the circuit boards. Make note of the location of each sensor connection. Refer to figures 103 and 104. The vortex sensor connection is on the left, the temperature sensor connection (if present) is second from the left, and the pressure sensor connection (if present) is the right most connector. Use small pliers to pull the sensor wiring connectors off of the circuit boards.
4. Locate and loosen the small set screw which locks the smaller enclosure cover in place. Unscrew the cover to expose the field wiring strip. Tag and remove the field wires.
5. Remove the screws that hold the black wiring label in place, remove the label.
6. Locate the 4 Phillips head screws which are spaced at 90-degrees around the terminal board. These screws hold the electronics stack in the enclosure. Loosen these screws (Note: that these are captive screws, they will stay inside the enclosure).
7. Carefully remove the electronics stack from the opposite side of the enclosure. If the electronics stack will not come out, gently tap the terminal strip with the screw driver handle. This will loosen the rubber sealing gasket on the other side of the enclosure wall. Be careful that the stack does not hang up on the loose sensor harnesses.
8. Repeat steps 1 through 6 in reverse order to install the new electronics stack.

Returning Equipment to the Factory

Factory Calibration—All Models

Sierra Instruments maintains a fully-equipped calibration laboratory. All measuring and test equipment used in the calibration of Sierra transducers are traceable to NIST Standards. Sierra is ISO-9001 registered and conforms to the requirements of ANSI/NCSSL-Z540 and ISO/IEC Guide 25.

Instructions for Returning Your Instrument for Service

The following information will help you return your instrument to Sierra Instruments' Factory Service Center and will ensure that your order is processed promptly. Prices may vary depending on the flow range, type of gas and operating pressure of your unit. To request detailed pricing, contact your local Sierra Instruments distributor or contact one of our offices directly.

Please follow these easy steps to return your instrument for factory service:

1. To obtain a Return Materials Authorization (RMA) number from the Sierra Instruments to <http://www.sierrainstruments.com/rma/new.php> to create a Sierra Account.
2. Once you have created an account, click on the Submit New RMA tab and fill in the RMA form and follow the instructions. You will receive an email confirmation once you have submitted your RMA.
3. Print a copy of the RMA (that now includes RMA#) and send a copy of the RMA form along with your meter back to the factory.

If you require service beyond calibration, but do not know which service(s) will be required, describe the symptoms as accurately as possible on the RMA form.

Pack your instrument carefully. Use the original packaging and foam or bubble wrap (packing peanuts NOT recommended) and include a copy of the RMA form (complete with Sierra supplied RMA number) with the unit(s).

Ship the unit(s) to the following address:

Sierra Instruments, Inc.
Attention: Factory Service Center
20 Ryan Ranch Road, Suite 109
Monterey, CA 93940 USA
RE: RMA# (your number)

Appendix A Product Specifications

Accuracy

Process Variables	240S Series In-Line Meters		241S Series Insertion Meters	
Fluid	Liquids	Gas & Steam	Liquids	Gas & Steam
Mass Flow Rate	±1% of rate over a 30:1 range ⁽³⁾	±1.5% of rate ⁽²⁾ over a 30:1 range ⁽³⁾	±1.5% of rate over a 30:1 range ⁽³⁾	±2% of rate ⁽²⁾ over a 30:1 range ⁽³⁾
Volumetric Flow Rate	±0.7% of rate over a 30:1 range ⁽³⁾	±1% of rate over a 30:1 range ⁽³⁾	±1.2% of rate over a 30:1 range ⁽³⁾	±1.5% of rate over a 30:1 range ⁽³⁾
Temperature	± 2° F (± 1° C)	± 2° F (± 1° C)	± 2° F (± 1° C)	± 2° F (± 1° C)
Pressure	0.3% of transducer full scale	0.3% of transducer full scale	0.3% of transducer full scale	0.3% of transducer full scale
Density	0.3% of reading	0.5% of reading ⁽²⁾	0.3% of reading	0.5% of reading ⁽²⁾

- Notes:
- (1) Accuracies stated are for the total mass flow through the pipe.
 - (2) Over 50 to 100% of the pressure transducer's full scale.
 - (3) Nominal rangeability is stated. Precise rangeability depends on fluid and pipe size.

Repeatability	<p>Mass Flow Rate: 0.2% of rate.</p> <p>Volumetric Flow Rate: 0.1% of rate.</p> <p>Temperature: ± 0.2° F (± 0.1° C).</p> <p>Pressure: 0.05% of full scale.</p> <p>Density: 0.1% of reading.</p>
Stability Over 12 Months	<p>Mass Flow Rate: 0.2% of rate maximum.</p> <p>Volumetric Flow Rate: Negligible error.</p> <p>Temperature: ± 0.1° F (± 0.5° C) maximum.</p> <p>Pressure: 0.1% of full scale maximum.</p> <p>Density: 0.1% of reading maximum.</p>
Response Time	Adjustable from 1 to 100 seconds.
Material Capability	<p>Series 240S In-Line Flow Meter:</p> <p>Any gas, liquid or steam compatible with 316L stainless steel, C276 hastelloy or A105 carbon steel. Not recommended for multi-phase fluids.</p>

Series 241S Insertion Flow Meter:

Any gas, liquid or steam compatible with 316L stainless steel. Not recommended for multi-phase fluids.

Flow Rates

Typical mass flow ranges are given in the following table. Precise flow depends on the fluid and pipe size. M23 insertion meters are applicable to pipe sizes from 3 inch and above. Consult factory for sizing program.

Water Minimum and Maximum Flow Rates									
Line Size	½-inch	¾-inch	1-inch	1.5-inch	2-inch	3-inch	4-inch	6-inch	8-inch
	15 mm	20 mm	25 mm	40 mm	50 mm	80 mm	100 mm	150 mm	200 mm
gpm	1	1.3	2.2	5.5	9.2	21	36	81	142
	22	40	67	166	276	618	1076	2437	4270
m³/hr	.23	.3	0.5	1.3	2.1	4.7	8.1	18	32
	5	9.1	15	38	63	140	244	554	970

Typical Air Minimum and Maximum Flow Rates (SCFM)									
Air at 70°F									
Pressure	Nominal Pipe Size (in)								
	0.5	0.75	1	1.5	2	3	4	6	8
0 psig	1.8	3	5	13	22	50	87	198	347
	18	41	90	221	369	826	1437	3258	5708
100 psig	5	9	15	38	63	141	245	555	972
	138	325	704	1730	2890	6466	11254	25515	44698
200 psig	7	13	21	52	86	193	335	761	1332
	258	609	1322	3248	5427	12140	21131	47911	83931
300 psig	8	15	25	63	104	234	407	922	1615
	380	896	1944	4775	7978	17847	31064	70431	123375
400 psig	10	18	29	72	120	269	467	1060	1857
	502	1183	2568	6309	10542	23580	41043	93057	163000
500 psig	11	20	33	80	134	300	521	1182	2071
	624	1472	3195	7849	13115	28034	51063	115775	203000

Typical Air Minimum and Maximum Flow Rates (nm ³ /hr) Air at 20°C									
Pressure	Nominal Pipe Size (mm)								
	15	20	25	40	50	80	100	150	200
0 barg	3	5	9	21	36	79	138	313	549
	28	66	142	350	584	1307	2275	5157	9034
5 barg	7	13	21	52	87	194	337	764	1339
	165	309	847	2080	3476	7775	13533	30682	53749
10 barg	9	17	29	70	117	262	457	1035	1814
	304	716	1554	3819	6381	14273	24844	56329	98676
15 barg	11	21	34	85	142	317	551	1250	2190
	442	1044	2265	5565	9299	20801	36205	82087	143801
20 barg	13	24	40	97	162	363	632	1434	2511
	582	1373	2979	7318	12229	27354	47612	107949	189105
30 barg	16	29	48	118	198	442	770	1745	3057
	862	2034	4414	10843	18119	40529	70544	159942	280187

Linear Range

Smart electronics corrects for lower flow down to a Reynolds number of 5,000. The Reynolds number is calculated using the fluid's actual temperature and pressure monitored by the meter. Rangeability depends on the fluid, process connections and pipe size. Consult factory for your application. Typical velocity range ability in standard applications is as follows:

Liquids 30:1 1 foot per second velocity minimum

30 feet per second velocity maximum

Gases 30:1 10 feet per second velocity minimum

300 feet per second velocity maximum

Typical Saturated Steam Minimum and Maximum Flow Rates (lb/hr)									
Pressure	Nominal Pipe Size (in)								
	0.5	0.75	1	1.5	2	3	4	6	8
5 psig	6.5	12	20	49	82	183	318	722	1264
	52	122	265	650	1087	2431	4231	9594	16806
100 psig	15	27	46	112	187	419	728	1652	2893
	271	639	1386	3405	5690	12729	22156	50233	87998
200 psig	20	37	62	151	253	565	983	2229	3905
	493	1163	2525	6203	10365	23184	40354	91494	160279
300 psig	24	45	74	182	304	680	1184	2685	4704
	716	1688	3664	9000	15040	33642	58556	132763	232575
400 psig	28	51	85	209	349	78	1358	3079	5393
	941	2220	4816	11831	19770	44222	76971	174516	305717
500 psig	31	57	95	233	389	870	1514	3433	6014
	1170	2760	5988	14711	24582	54987	95710	217001	380148

241S Pressure Ratings				
Probe Seal	Process Connection	Material	Rating	Ordering Code
Compression Fitting	2-inch MNPT	316L SS	ANSI 600 lb	CM
	2-inch 150 lb flange, DN50 PN16, JIS 10K	316L SS	ANSI 150 lb, PN16 JIS 10K	CF, CFD, CFJ
	2-inch 300 lb flange, DN50 PN40, JIS 20K	316L SS	ANSI 300 lb, PN40 JIS 20K	CG, CGD, CGJ
	2-inch 600 lb flange, DN50 PN63, JIS 30K	316L SS	ANSI 600 lb, PN63 JIS 30K	CH, CHD, CHJ
	2-inch 900 lb flange	316L SS	ANSI 900 lb	CI
Packing Gland	2-inch MNPT	316L SS	50 psig	PM
	2-inch 150 lb flange, DN50 PN16, JIS 10K	316L SS	50 psig	PF, PFD, PFJ
	2-inch 300 lb flange, DN50 PN40, JIS 20K	316L SS	50 psig	PG, PGD, PGJ
Packing Gland with Removable Retractor	2-inch MNPT	316L SS	ANSI 300 lb	PM, 241-RR
	2-inch 150 lb flange, DN50, PN16	316L SS	ANSI 150 lb	PF, PFD, 241-RR
	2-inch 300 lb flange	316L SS	ANSI 300 lb	PG, PGD, 241-RR
Packing Gland with Permanent Retractor	2-inch MNPT	316L SS	ANSI 600 lb	PMR
	2-inch 150 lb flange, DN50 PN16, JIS 10K	316L SS	ANSI 150 lb	PFR, PFDR, PFJR
	2-inch 300 lb flange, DN50, PN40, JIS 20K	316L SS	ANSI 300 lb	PGR, PGDR, PGJR
	2-inch 600 lb flange, DN50 PN63, JIS 30K	316L SS	ANSI 600 lb	PHR, PHDR, PHJR
	2-inch 900 lb flange	316L SS	ANSI 900 lb	PIR

Pressure Transducer Ranges

Pressure Sensor Ranges ⁽¹⁾ , psia (bara)			
Full Scale Operating Pressure		Maximum Over-Range Pressure	
psia	(bara)	psia	(bara)
30	2	60	4
100	7	200	14
300	20	600	40
500	35	1000	70
1500	100	2500	175

Note: (1) To maximize accuracy, specify the lowest full scale operating pressure range for the application. To avoid damage, the flow meter must never be subjected to pressure above the over-range pressure shown above.

Power Requirements 12 to 36 VDC, 25 mA, 1 W max., Loop Powered Volumetric or Mass
 12 to 36 VDC, 300 mA, 9 W max. Multiparameter Mass options
 100 to 240 VAC, 50/60 Hz, 5 W max. Multiparameter Mass options

Use a Class 2 isolated power supply that is grounded, provides DC output, and has no more than 10% output ripple.

Installation (Over-voltage) Category II for transient over-voltages

AC & DC Mains supply voltage fluctuations are not to exceed +/-10% of the rated supply voltage range.

User is responsible for the provision of an external disconnect means, disconnect line 1 and line 2 when 220 / 240 VAC power is used, also provide over-current protection for the equipment (both AC and DC models).

Display Alphanumeric 2 x 16 LCD digital display.
 Six push-button switches (up, down, right, left, enter, exit) operable through explosion-proof window using hand-held magnet. Viewing at 90-degree mounting intervals.

Process Fluid and Ambient Temperature

Process Fluid:

Standard temperature sensor: -330° F to 500° F (-200°C to 260°C)

High temperature sensor: to 750° F (400° C)

Ambient:

Operating temperature range: -40° F to 140° F (-40° C to 60° C)

Storage temperature range: -40° F to 185° F (-40° C to 85° C)

Maximum relative humidity: 0-98%, non-condensing conditions

Maximum altitude: -2000 to 14,000 feet (-610 to 4268 meters)

Pollution Degree 2 for the ambient environment

Output Signals (1)

Analog: Volumetric Meter: field rangeable linear 4-20 mA output signal (1200 Ohms maximum loop resistance) selected by user for mass flow rate or volumetric flow rate.

Communications: HART, MODBUS, RS485, BACnet

Multiparameter Meter: up to three field rangeable linear 4-20 mA output signals (1200 Ohms maximum loop resistance) selected from the five parameters—mass flow rate, volumetric flow rate, temperature, pressure and density.

Pulse: Pulse output for totalization is a 50-millisecond duration pulse operating a solid-state relay capable of switching 40 VDC, 40 mA maximum.

Note: (1) All outputs are optically isolated and require external power for operation.

Alarms

Up to three programmable solid-state relays for high, low or window alarms capable of switching 40 VDC, 40 mA maximum.

Totalizer

Based on user-determined flow units, six significant figures in scientific notation. Total stored in non-volatile memory.

Wetted Materials

Series 240S In-Line Flow Meter:

316L stainless steel standard.

C276 hastelloy or A105 carbon steel optional.

Series 241S Insertion Flow Meter:

316L stainless steel standard.

Teflon® packing gland below 500° F (260° C).

Graphite packing gland above 500° F (260° C).

Enclosure Protection Classification NEMA 4X and IP66 cast enclosure.

Electrical Ports Two 3/4-inch female NPT ports.

Mounting Connections Series 240S: Wafer, 150, 300, 600, 900 lb ANSI flange, PN16, PN40, PN63 flange, JIS 10K, 20K, 30K flange.

Series 241S Permanent installation: 2-inch MNPT; 150, 300, 600, 900 lb ANSI flange, PN16, PN40, PN63 flange, JIS 10K, 20K, 30K flange with compression fitting probe seal.

Series 241SHot Tap(1) Installation: 2-inch MNPT; 150, 300, 600, 900 lb ANSI flange, PN16, PN40, PN63 flange, JIS 10K, 20K, 30K flange and optional retractor with packing gland probe seal.

Note: (1) Removable under line pressure.

Mounting Position Series 240S In-Line Flow Meter: No effect.

Series 241S Insertion Flow Meter: Meter must be perpendicular with-in $\pm 5^\circ$ of the pipe centerline.

Certifications Material Certificate – US Mill certs on all wetted parts

Pressure Test Certificate

Certificate of Conformance

NACE Certification (MR0175)

Oxygen Cleaning (CGA G-4).

Approvals FM / FMC, ATEX, IECEx

ORDERING THE 240 IN-LINE

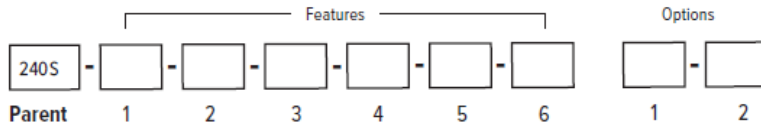

Parent 1 2 3 4 5 6 1 2
 Instructions: To order a 240S please fill in each number block by selecting the codes from the corresponding features below and following pages.

Parent Number	
240S	InnovaMass Inline Multiparameter Mass Vortex Flow Meter
240S-R-XX	InnovaMass Inline Reducing Vortex Flow Meter (XX= Feature 2, FloR-W body ; example 240S-R-F2)

Feature 1: Multiparameter Options	
V	Volumetric flow meter for liquid, gas and steam
VT	Velocity and Temperature Sensors. Mass measurement with temperature compensation
VTP	Velocity, temperature and pressure sensors. Mass measurement with pressure and temperature compensation
VETEP	Velocity, External RTD Temperature input, External 4-20mA input (T or P)
VETEP-EMS	Velocity, External RTD Temperature input, External 4-20mA input (T or P). Energy Monitoring option. Permits real-time calculation of energy consumption. Not loop powered. Requires DC or AC power
VTEP	Velocity, Temperature and External 4-20mA input (T or P)
VTEP-EMS	Velocity, Temperature and External 4-20mA input (T or P). Energy Monitoring option. Permits real-time calculation of energy consumption.
VT-EMS	Velocity and Temperature Sensors. Energy Monitoring option. Permits real-time calculation of energy consumption.
VTP-EMS	Velocity, Temperature and Pressure Sensors. Energy Monitoring option. Permits real-time calculation of energy consumption.

Feature 2 Codes For 240s Only. Go To Page 11 To See Codes For Flow Bodies Used With Reducer Vortex 240s-R.

Feature 2: Flow Body ANSI 316L (240S Only)							
F2	1/2-inch (15mm) ANSI 150 lb Flanged	G2	1/2-inch (15mm) ANSI 300 lb Flanged	H2	1/2-inch (15mm) ANSI 600 lb Flanged	I2	1/2-inch (15mm) ANSI 900 lb Flanged
F3	3/4-inch (20mm) ANSI 150 lb Flanged	G3	3/4-inch (20mm) ANSI 300 lb Flanged	H3	3/4-inch (20mm) ANSI 600 lb Flanged	I3	3/4-inch (20mm) ANSI 900 lb Flanged
F4	1-inch (25mm) ANSI 150 lb Flanged	G4	1-inch (25mm) ANSI 300 lb Flanged	H4	1-inch (25mm) ANSI 600 lb Flanged	I4	1-inch (25mm) ANSI 900 lb Flanged
F5	1.5-inch (40mm) ANSI 150 lb Flanged	G5	1.5-inch (40mm) ANSI 300 lb Flanged	H5	1.5-inch (40mm) ANSI 600 lb Flanged	I5	1.5-inch (40mm) ANSI 900 lb Flanged
F6	2-inch (50mm) ANSI 150 lb Flanged	G6	2-inch (50mm) ANSI 300 lb Flanged	H6	2-inch (50mm) ANSI 600 lb Flanged	I6	2-inch (50mm) ANSI 900 lb Flanged
F7	3-inch (80mm) ANSI 150 lb Flanged	G7	3-inch (80mm) ANSI 300 lb Flanged	H7	3-inch (80mm) ANSI 600 lb Flanged	I7	3-inch (80mm) ANSI 900 lb Flanged
F8	4-inch (100mm) ANSI 150 lb Flanged	G8	4-inch (100mm) ANSI 300 lb Flanged	H8	4-inch (100mm) ANSI 600 lb Flanged	I8	4-inch (100mm) ANSI 900 lb Flanged
F9	6-inch (150mm) ANSI 150 lb Flanged	G9	6-inch (150mm) ANSI 300 lb Flanged	H9	6-inch (150mm) ANSI 600 lb Flanged	I9	6-inch (150mm) ANSI 900 lb Flanged
F10	8-inch (200mm) ANSI 150 lb Flanged	G10	8-inch (200mm) ANSI 300 lb Flanged	H10	8-inch (200mm) ANSI 600 lb Flanged	I10	8-inch (200mm) ANSI 900 lb Flanged
F11	10-inch (250mm) ANSI 150 lb Flanged	G11	10-inch (250mm) ANSI 300 lb Flanged	H11	10-inch (250mm) ANSI 600 lb Flanged	I11	10-inch (250mm) ANSI 900 lb Flanged
F12	12-inch (300mm) ANSI 150 lb Flanged	G12	12-inch (300mm) ANSI 300 lb Flanged	H12	12-inch (300mm) ANSI 600 lb Flanged	I12	12-inch (300mm) ANSI 900 lb Flanged

Note: For Flow Body 316L

Feature 2: Flow Body Carbon Steel (240S Only)							
FC5	1.5-inch (40mm) ANSI 150 lb Flanged	GC5	1.5-inch (40mm) ANSI 300 lb Flanged	HC5	1.5-inch (40mm) ANSI 600 lb Flanged	IC5	1.5-inch (40mm) ANSI 900 lb Flanged
FC6	2-inch (50mm) ANSI 150 lb Flanged	GC6	2-inch (50mm) ANSI 300 lb Flanged	HC6	2-inch (50mm) ANSI 600 lb Flanged	IC6	2-inch (50mm) ANSI 900 lb Flanged
FC7	3-inch (80mm) ANSI 150 lb Flanged	GC7	3-inch (80mm) ANSI 300 lb Flanged,	HC7	3-inch (80mm) ANSI 600 lb Flanged	IC7	3-inch (80mm) ANSI 900 lb Flanged
FC8	4-inch (100mm) ANSI 150 lb Flanged	GC8	4-inch (100mm) ANSI 300 lb Flanged,	HC8	4-inch (100mm) ANSI 600 lb Flanged,	IC8	4-inch (100mm) ANSI 900 lb Flanged
FC9	6-inch (150mm) ANSI 150 lb Flanged	GC9	6-inch (150mm) ANSI 300 lb Flanged	HC9	6-inch (150mm) ANSI 600 lb Flanged,	IC9	6-inch (150mm) ANSI 900 lb Flanged
FC10	8-inch (200mm) ANSI 150 lb Flanged	GC10	8-inch (200mm) ANSI 300 lb Flanged	HC10	8-inch (200mm) ANSI 600 lb Flanged	IC10	8-inch (200mm) ANSI 900 lb Flanged,
FC11	10-inch (250mm) ANSI 150 lb Flanged	GC11	10-inch (250mm) ANSI 300 lb Flanged	HC11	10-inch (250mm) ANSI 600 lb Flanged	IC11	10-inch (250mm) ANSI 900 lb Flanged
FC12	12-inch (300mm) ANSI 150 lb Flanged	GC12	12-inch (300mm) ANSI 300 lb Flanged	HC12	12-inch (300mm) ANSI 600 lb Flanged	IC12	12-inch (300mm) ANSI 900 lb Flanged

Note: For Flow Body Carbon Steel (CS)

ORDERING THE 240S IN-LINE (CONTINUED)

Feature 2: Flow Body DN, PN #, 316L (240S Only)					
FD2	1/2-inch (15mm) PN16 Flanged, 316L	GD2	1/2-inch (15mm) PN40 Flanged, 316L	HD2	1/2-inch (15mm) PN63 Flanged, 316L
FD3	3/4-inch (20mm) PN16 Flanged, 316L	GD3	3/4-inch (20mm) PN40 Flanged, 316L	HD3	3/4-inch (20mm) PN63 Flanged, 316L
FD4	1-inch (25mm) PN16 Flanged, 316L	GD4	1-inch (25mm) PN40 Flanged, 316L	HD4	1-inch (25mm) PN63 Flanged, 316L
FD5	1.5-inch (40mm) PN16 Flanged, 316L	GD5	1.5-inch (40mm) PN40 Flanged, 316L	HD5	1.5-inch (40mm) PN63 Flanged, 316L
FD6	2-inch (50mm) PN16 Flanged, 316L	GD6	2-inch (50mm) PN40 Flanged, 316L	HD6	2-inch (50mm) PN63 Flanged, 316L
FD7	3-inch (80mm) PN16 Flanged, 316L	GD7	3-inch (80mm) PN40 Flanged, 316L	HD7	3-inch (80mm) PN63 Flanged, 316L
FD8	4-inch (100mm) PN16 Flanged, 316L	GD8	4-inch (100mm) PN40 Flanged, 316L	HD8	4-inch (100mm) PN63 Flanged, 316L
FD9	6-inch (150mm) PN16 Flanged, 316L	GD9	6-inch (150mm) PN40 Flanged, 316L	HD9	6-inch (150mm) PN63 Flanged, 316L
FD10	8-inch (200mm) PN16 Flanged, 316L	GD10	8-inch (200mm) PN40 Flanged, 316L	HD10	8-inch (200mm) PN63 Flanged, 316L
FD11	10-inch (250mm) PN16 Flanged, 316L	GD11	10-inch (250mm) PN40 Flanged, 316L	HD11	10-inch (250mm) PN63 Flanged, 316L
FD12	12-inch (300mm) PN16 Flanged, 316L	GD12	12-inch (300mm) PN40 Flanged, 316L	HD12	12-inch (300mm) PN63 Flanged, 316L

Feature 2: Flow Body JIS, 316L (240S Only)					
FJ2	1/2-inch (15mm) JIS 10k Flanged, 316L	GJ2	1/2-inch (15mm) JIS 20k Flanged, 316L	HJ2	1/2-inch (15mm) JIS 30k Flanged, 316L
FJ3	3/4-inch (20mm) JIS 10k Flanged, 316L	GJ3	3/4-inch (20mm) JIS 20k Flanged, 316L	HJ3	3/4-inch (20mm) JIS 30k Flanged, 316L
FJ4	1-inch (25mm) JIS 10k Flanged, 316L	GJ4	1-inch (25mm) JIS 20k Flanged, 316L	HJ4	1-inch (25mm) JIS 30k Flanged, 316L
FJ5	1.5-inch (40mm) JIS 10k Flanged, 316L	GJ5	1.5-inch (40mm) JIS 20k Flanged, 316L	HJ5	1.5-inch (40mm) JIS 30k Flanged, 316L
FJ6	2-inch (50mm) JIS 10k Flanged, 316L	GJ6	2-inch (50mm) JIS 20k Flanged, 316L	HJ6	2-inch (50mm) JIS 30k Flanged, 316L
FJ7	3-inch (80mm) JIS 10k Flanged, 316L	GJ7	3-inch (80mm) JIS 20k Flanged, 316L	HJ7	3-inch (80mm) JIS 30k Flanged, 316L
FJ8	4-inch (100mm) JIS 10k Flanged, 316L	GJ8	4-inch (100mm) JIS 20k Flanged, 316L	HJ8	4-inch (100mm) JIS 30k Flanged, 316L
FJ9	6-inch (150mm) JIS 10k Flanged, 316L	GJ9	6-inch (150mm) JIS 20k Flanged, 316L	HJ9	6-inch (150mm) JIS 30k Flanged, 316L
FJ10	8-inch (200mm) JIS 10k Flanged, 316L	GJ10	8-inch (200mm) JIS 20k Flanged, 316L	HJ10	8-inch (200mm) JIS 30k Flanged, 316L
FJ11	10-inch (250mm) JIS 10k Flanged, 316L	GJ11	10-inch (250mm) JIS 20k Flanged, 316L	HJ11	10-inch (250mm) JIS 30k Flanged, 316L
FJ12	12-inch (300mm) JIS 10k Flanged, 316L	GJ12	12-inch (300mm) JIS 20k Flanged, 316L	HJ12	12-inch (300mm) JIS 30k Flanged, 316L

Feature 2: Flow Body ANSI Wafer, 316L (240S Only)	
W2	1/2-inch (15mm) ANSI 600 316L Wafer
W3	3/4-inch (20mm) ANSI 600 lb 316L Wafer
W4	1-inch (25mm) ANSI 600 lb 316L Wafer
W5	1.5-inch (40mm) ANSI 600 lb 316L Wafer
W6	2-inch (50mm) ANSI 600 lb 316L Wafer
W7	3-inch (80mm) ANSI 600 lb 316L Wafer
W8	4-inch (100mm) ANSI 600 lb 316L Wafer

ORDERING THE 240S IN-LINE (CONTINUED)

Feature 2 Codes on this page for Flow Bodies used with REDUCER VORTEX 240S-R only.

Feature 2: Flow Body (240S-R Only)			
R-F3	3/4-inch (20mm) ANSI 150 lb Flanged, 316L R-With a 1/2" (15mm) bore reducing meter	R-G3	3/4-inch (20mm) ANSI 300 lb Flanged, 316L R-With a 1/2" (15mm) bore reducing meter
R-F4	1-inch (25mm) ANSI 150 lb Flanged, 316L R-With a 1/2" (15mm) bore reducing meter	R-G4	1-inch (25mm) ANSI 300 lb Flanged, 316L R-With a 1/2" (15mm) bore reducing meter
R-F5	1.5-inch (40mm) ANSI 150 lb Flanged, 316L R-With a 1" (25mm) bore reducing meter	R-G5	1.5-inch (40mm) ANSI 300 lb Flanged, 316L R-With a 1" (25mm) bore reducing meter
R-F6	2-inch (50mm) ANSI 150 lb Flanged, 316L R-With a 1.5" (40mm) bore reducing meter	R-G6	2-inch (50mm) ANSI 300 lb Flanged, 316L R-With a 1.5" (40mm) bore reducing meter
R-F7	3-inch (80mm) ANSI 150 lb Flanged, 316L R-With a 2" (50mm) bore reducing meter	R-G7	3-inch (80mm) ANSI 300 lb Flanged, 316L R-With a 2" (50mm) bore reducing meter
R-F8	4-inch (100mm) ANSI 150 lb Flanged, 316L R-With a 3" (80mm) bore reducing meter	R-G8	4-inch (100mm) ANSI 300 lb Flanged, 316L R-With a 3" (80mm) bore reducing meter
R-F9	6-inch (150mm) ANSI 150 lb Flanged, 316L R-With a 4" (100mm) bore reducing meter	R-G9	6-inch (150mm) ANSI 300 lb Flanged, 316L R-With a 4" (100mm) bore reducing meter
R-F10	8-inch (200mm) ANSI 150 lb Flanged, 316L R-With a 6" (150mm) bore reducing meter	R-G10	8-inch (200mm) ANSI 300 lb Flanged, 316L R-With a 6" (150mm) bore reducing meter
R-F11	10-inch (250mm) ANSI 150 lb Flanged, 316L R-With an 8" (200mm) bore reducing meter	R-G11	10-inch (250mm) ANSI 300 lb Flanged, 316L R-With an 8" (200mm) bore reducing meter
R-F12	12-inch (300mm) ANSI 150 lb Flanged, 316L R-With a 10" (250mm) bore reducing meter	R-G12	12-inch (300mm) ANSI 300 lb Flanged, 316L R-With a 10" (250mm) bore reducing meter

Feature 2: Flow Body (240S-R Only)			
R-H3	3/4-inch (20mm) ANSI 600 lb Flanged, 316L R-With a 1/2" (15mm) bore reducing meter	R-I3	3/4-inch (20mm) ANSI 900 lb Flanged, 316L R-With a 1/2" (15mm) bore reducing meter
R-H4	1-inch (25mm) ANSI 600 lb Flanged, 316L R-With a 1/2" (15mm) bore reducing meter	R-I4	1-inch (25mm) ANSI 900 lb Flanged, 316L R-With a 1/2" (15mm) bore reducing meter
R-H5	1.5-inch (40mm) ANSI 600 lb Flanged, 316L R-With a 1" (25mm) bore reducing meter	R-I5	1.5-inch (40mm) ANSI 900 lb Flanged, 316L R-With a 1" (25mm) bore reducing meter
R-H6	2-inch (50mm) ANSI 600 lb Flanged, 316L R-With a 1.5" (40mm) bore reducing meter	R-I6	2-inch (50mm) ANSI 900 lb Flanged, 316L R-With a 1.5" (40mm) bore reducing meter
R-H7	3-inch (80mm) ANSI 600 lb Flanged, 316L R-With a 2" (50mm) bore reducing meter	R-I7	3-inch (80mm) ANSI 900 lb Flanged, 316L R-With a 2" (50mm) bore reducing meter
R-H8	4-inch (100mm) ANSI 600 lb Flanged, 316L R-With a 3" (80mm) bore reducing meter	R-I8	4-inch (100mm) ANSI 900 lb Flanged, 316L R-With a 3" (80mm) bore reducing meter
R-H9	6-inch (150mm) ANSI 600 lb Flanged, 316L R-With a 4" (100mm) bore reducing meter	R-I9	6-inch (150mm) ANSI 900 lb Flanged, 316L R-With a 4" (100mm) bore reducing meter
R-H10	8-inch (200mm) ANSI 600 lb Flanged, 316L R-With a 6" (150mm) bore reducing meter	R-I10	8-inch (200mm) ANSI 900 lb Flanged, 316L R-With a 6" (150mm) bore reducing meter
R-H11	10-inch (250mm) ANSI 600 lb Flanged, 316L R-With an 8" (200mm) bore reducing meter	R-IG11	10-inch (250mm) ANSI 900 lb Flanged, 316L R-With an 8" (200mm) bore reducing meter
R-H12	12-inch (300mm) ANSI 600 lb Flanged, 316L R-With a 10" (250mm) bore reducing meter	R-I12	12-inch (300mm) ANSI 900 lb Flanged, 316L R-With a 10" (250mm) bore reducing meter

Feature 2: Flow Body Wafer 316L (240S-R Only)	
R-W3	3/4-inch (20mm) by 1/2-inch (15mm) Nominal Bore Reducing Wafer Meter, ANSI 600 lb 316L
R-W4	1-inch (25mm) by 3/4" (20mm) Nominal Bore Reducing Wafer Meter, ANSI 600 lb 316L
R-W5	1.5-inch (40mm) by 1-inch (25mm) Nominal Bore Reducing Wafer Meter, ANSI 600 lb 316L
R-W6	2-inch (50mm) by 1.5-inch (40mm) Nominal Bore Reducing Wafer Meter, ANSI 600 lb 316L
R-W7	3-inch (80mm) by 2-inch (50mm) Nominal Bore Reducing Wafer Meter, ANSI 600 lb 316L
R-W8	4-inch (100mm) by 3-inch (80mm) Nominal Bore Reducing Wafer Meter, ANSI 600 lb 316L

ORDERING THE 240S IN-LINE (CONTINUED)

Feature 3: Electronics Enclosure

E2-DD	Local Electronics NEMA 4X Enclosure Mounted on Meter. Digital Display with pushbuttons included.	E4 (-)DD	Remote Electronics NEMA 4X. Specify Cable Length in Parenthesis, 50 ft max (15.24 m). Digital display with pushbuttons included.
--------------	--	-----------------	--

Note : No charge for extra cable length.

Feature 4: Power Inputs and Digital/Analog Output

PV1L-V4LH	Loop Power Option - One Analog Output (4-20mA), one pulse, one scaled frequency, HART communication protocol -12-36 VDC required on loop powered meters
PV1-V4H	One Analog Output (4-20mA), one alarm, one pulse, one scaled frequency, HART communication protocol - Not Loop Powered 12-36 VDC
PV1-V4M	One analog output (4-20 mA), one alarm, one pulse, one scaled frequency, MODBUS RTU communication protocol - Not Loop Powered 12-36 VDC
PV1-V4B	One Analog Output (4-20mA), one alarm, one pulse, one scaled frequency, BACnet MS/TP communication protocol - Not Loop Powered 12-36 VDC
PV1-V6H	Three analog outputs (4-20 mA), three alarms, one pulse, one scaled frequency, HART communication protocol - Not Loop Powered 12-36 VDC
PV1-V6M	Three analog outputs (4-20 mA), three alarms, one pulse, one scaled frequency, MODBUS RTU communication protocol - Not Loop Powered 12-36 VDC
PV1-V6B	3 Analog Outputs (4-20mA), three alarms, one pulse, one scaled frequency output, BACnet MS/TP communication protocol - Not Loop Powered 12-36 VDC
PV1-V4M-IP	One analog output (4-20 mA), one alarm, one pulse, one scaled frequency, MODBUS TCP/IP communication protocol - Not Loop Powered 12-28 VDC powered over Ethernet, 5 Watts maximum
PV1-V4B-IP	One Analog Output (4-20mA), one alarm, one pulse, one scaled frequency, BACnet /IP communication protocol - Not Loop Powered 12-28 VDC powered over Ethernet, 5 Watts maximum
PV1-V6M-IP	Three analog outputs (4-20 mA), three alarms, one pulse, one scaled frequency, Ethernet, MODBUS TCP/IP communication protocol - Not Loop Powered 12-28 VDC powered over Ethernet, 5 Watts maximum
PV1-V6B-IP	3 Analog Outputs (4-20mA), three alarms, one pulse, one scaled frequency output, Ethernet, BACnet /IP communication protocol - Not Loop Powered, 2-28 VDC powered over Ethernet, 5 Watts maximum
PS-V4H	One Analog Output (4-20mA), one alarm, one pulse, one scaled frequency, HART communication protocol - 100-240 VAC, 50/60Hz Linepower, 5 Watts maximum
PS-V4M	One analog output (4-20 mA), one alarm, one pulse, one scaled frequency, MODBUS RTU communication protocol - 100-240 VAC, 50/60Hz Linepower, 5 Watts maximum
PS-V4B	One Analog Output (4-20mA), one alarm, one pulse, one scaled frequency, BACnet MS/TP communication protocol - 100-240 VAC, 50/60Hz Linepower, 5 Watts maximum
PS-V6H	Three analog outputs (4-20 mA), three alarms, one pulse, one scaled frequency, HART communication protocol - 100-240 VAC, 50/60Hz Linepower, 5 Watts maximum
PS-V6M	Three analog outputs (4-20 mA), three alarms, one pulse, one scaled frequency, MODBUS RTU communication protocol - 100-240 VAC, 50/60Hz Linepower, 5 Watts maximum
PS-V6B	3 Analog Outputs (4-20mA), three alarms, one pulse, one scaled frequency output, BACnet MS/TP communication protocol - 100-240 VAC, 50/60Hz Linepower, 5 Watts maximum

Feature 5: Process Temperature

ST	Standard Temperatures -330°F to 500°F (-200°C to 260°C)	HT	High Temperatures up to 750°F (400°C)
-----------	---	-----------	---------------------------------------

Feature 6: Process Pressure

MP0	No Pressure Sensor
MP1	Maximum 30 psia (2 bara), Proof 60 psia (4 bara)
MP2	Maximum 100 psia (7 bara), Proof 200 psia (14 bara)
MP3	Maximum 300 psia (20 bara), Proof 600 psia (41 bara)
MP4	Maximum 500 psia (34 bara), Proof 1000 psia (64 bara)
MP5	Maximum 1500 psia (100 bara), Proof 2500 psia (175 bara)

Option 1: Certification and Cleaning

MC	Material Certificates--US Mill certs on all R-Wetted parts
PT	Pressure Test Certificate
CC	Certificate of Conformance
NC	NACE Certification
O2	Oxygen Cleaning
PED	PED certified bodies (Stainless steel meters only)

Option 2: Remote Cables

ARM25V	25' Armored Cable R-With Glands (ATEX, IECEX) V meter only - Adder to Remote option
ARM50V	50' Armored Cable R-With Glands (ATEX, IECEX) V meter only - Adder to Remote option
ARM25VTP	25' Armored Cable R-With Glands (ATEX, IECEX) VT, VTP meter only - Adder to Remote option
ARM50VTP	50' Armored Cable R-With Glands (ATEX, IECEX) VT, VTP meter only - Adder to Remote option

Note: An Application Data Sheet (ADS) must be completely filled in for each item ordered. Non-compliance will delay delivery.

ORDERING THE 241S INSERTION

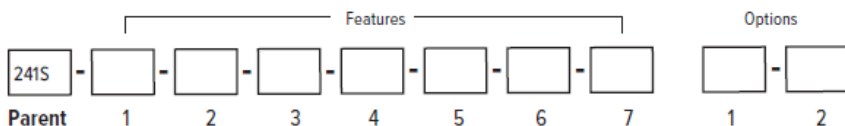

Instructions: To order a 241S please fill in each number block by selecting the codes from the corresponding features below and following pages.

Parent Number	
241S	InnovaMass Insertion Multiparameter Mass Vortex Meter

Feature 1: Multiparameter Options	
V	Volumetric flow meter for liquid, gas and steam
VT	Velocity and Temperature Sensors. Mass measurement with temperature compensation
VTP	Velocity, temperature and pressure sensors. Mass measurement with pressure and temperature compensation
VETEP	Velocity, External RTD Temperature input, External 4-20mA input (T or P)
VETEP-EMS	Velocity, External RTD Temperature input, External 4-20mA input (T or P). Energy Monitoring option. Permits real-time calculation of energy consumption. Not loop powered. Requires DC or AC power
VTEP	Velocity, Temperature and External 4-20mA input (T or P)
VTEP-EMS	Velocity, Temperature and External 4-20mA input (T or P). Energy Monitoring option. Permits real-time calculation of energy consumption.
VT-EMS	Velocity and Temperature Sensors. Energy Monitoring option. Permits real-time calculation of energy consumption.
VTP-EMS	Velocity, Temperature and Pressure Sensors. Energy Monitoring option. Permits real-time calculation of energy consumption.

Feature 2: Probe Length	
LS	Standard probe
LC	Compact Probe Available only for compression fitting connections CM, CF, CG, CH, CFD, CGD, AND CHD
LE	Extended Probe: Ensure the extended length (xxx-LE) probe is selected if using a retractor

Note: See Feature 7 to select the proper process connection.

Feature 3: Electronics Enclosure	
E2-DD	Local Electronics NEMA 4X Enclosure Mounted on Meter. Digital Display with pushbuttons included.
E4(-)DD	Remote Electronics NEMA 4X. Specify Cable Length in Parenthesis, 50 ft max (15.24 m). Digital display with pushbuttons included

Note: No charge for extra cable length.

ORDERING THE 241S INSERTION (CONTINUED)

Feature 4: Power Inputs and Digital/Analog Output	
PV1L-V4LH	Loop Power Option - One Analog Output (4-20mA), one pulse, one scaled frequency, HART communication protocol -12-36 VDC required on loop powered meters
PV1-V4H	One Analog Output (4-20mA), one alarm, one pulse, one scaled frequency, HART communication protocol - Not Loop Powered 12-36 VDC
PV1-V4M	One analog output (4-20 mA), one alarm, one pulse, one scaled frequency, MODBUS RTU communication protocol - Not Loop Powered 12-36 VDC
PV1-V4B	One Analog Output (4-20mA), one alarm, one pulse, one scaled frequency, BACnet MS/TP communication protocol - Not Loop Powered 12-36 VDC
PV1-V6H	Three analog outputs (4-20 mA), three alarms, one pulse, one scaled frequency, HART communication protocol - Not Loop Powered 12-36 VDC
PV1-V6M	Three analog outputs (4-20 mA), three alarms, one pulse, one scaled frequency, MODBUS RTU communication protocol - Not Loop Powered 12-36 VDC
PV1-V6B	3 Analog Outputs (4-20mA), three alarms, one pulse, one scaled frequency output, BACnet MS/TP communication protocol - Not Loop Powered 12-36 VDC
PV1-V4M-IP	One analog output (4-20 mA), one alarm, one pulse, one scaled frequency, MODBUS TCP/IP communication protocol - Not Loop Powered 12-28 VDC powered over Ethernet, 5 Watts maximum
PV1-V4B-IP	One Analog Output (4-20mA), one alarm, one pulse, one scaled frequency, BACnet /IP communication protocol - Not Loop Powered 12-28 VDC powered over Ethernet, 5 Watts maximum
PV1-V6M-IP	Three analog outputs (4-20 mA), three alarms, one pulse, one scaled frequency, Ethernet, MODBUS TCP/IP communication protocol - Not Loop Powered 12-28 VDC powered over Ethernet, 5 Watts maximum
PV1-V6B-IP	3 Analog Outputs (4-20mA), three alarms, one pulse, one scaled frequency output, Ethernet, BACnet /IP communication protocol - Not Loop Powered, 12-28 VDC powered over Ethernet, 5 Watts maximum
PS-V4H	One Analog Output (4-20mA), one alarm, one pulse, one scaled frequency, HART communication protocol - 100-240 VAC, 50/60Hz Linepower, 5 Watts maximum
PS-V4M	One analog output (4-20 mA), one alarm, one pulse, one scaled frequency, MODBUS RTU communication protocol - 100-240 VAC, 50/60Hz Linepower, 5 Watts maximum
PS-V4B	One Analog Output (4-20mA), one alarm, one pulse, one scaled frequency, BACnet MS/TP communication protocol - 100-240 VAC, 50/60Hz Linepower, 5 Watts maximum
PS-V6H	Three analog outputs (4-20 mA), three alarms, one pulse, one scaled frequency, HART communication protocol - 100-240 VAC, 50/60Hz Linepower, 5 Watts maximum
PS-V6M	Three analog outputs (4-20 mA), three alarms, one pulse, one scaled frequency, MODBUS RTU communication protocol - 100-240 VAC, 50/60Hz Linepower, 5 Watts maximum
PS-V6B	3 Analog Outputs (4-20mA), three alarms, one pulse, one scaled frequency output, BACnet MS/TP communication protocol - 100-240 VAC, 50/60Hz Linepower, 5 Watts maximum

Feature 5: Process Temperature	
ST	Standard process temperature -330°F to 500°F (-200°C to 260°C)
HT	High Temperatures up to 750°F (400°C)

Feature 6: Process Pressure	
MP0	No Pressure Sensor
MP1	Maximum 30 psia (2 bara), Proof 60 psia (4 bara)
MP2	Maximum 100 psia (7 bara), Proof 200 psia (14 bara)
MP3	Maximum 300 psia (20 bara), Proof 600 psia (41 bara)
MP4	Maximum 500 psia (34 bara), Proof 1000 psia (64 bara)
MP5	Maximum 1500 psia (100 bara), Proof 2500 psia (175 bara)

Feature 7: Process Connection (Compression Fittings ANSI)	
CM	Compression Fitting, stem seal 2-inch Male NPT process connection, 600 lb pressure rating.
CF	Compression Fitting, probe seal 2-inch 150 lb Flange process connection
CG	Compression Fitting, stem seal 2-inch 300 lb Flange process connection
CH	Compression Fitting, stem seal 2-inch 600 lb Flange process connection
CI	Compression Fitting, stem seal 2-inch 900 lb Flange process connection

Feature 7: Process Connection (Compression Fittings DN)	
CFD	Compression Fitting stem seal, DN50 PN16 process connection
CGD	Compression Fitting, DN50 PN40 process connection
CHD	Compression Fitting stem seal, DN50 PN63 process connection

Feature 7: Process Connection (Compression Fittings JIS)	
CMJ	Compression Fitting stem seal, 2-inch Male NPT process connection, JIS 30K pressure rating.
CFJ	Compression Fitting stem seal, 2-inch JIS 10K process connection
CGJ	Compression Fitting, 2-inch JIS 20K process connection
CHJ	Compression Fitting stem seal, 2-inch JIS 30K process connection

ORDERING THE 241S INSERTION (CONTINUED)

Feature 7: Process Connection (Packing Glands No Retractor ANSI)	
PM	Packing Gland* stem seal, 2-inch Male NPT process connection, 50 psig (3.5 barg) maximum process pressure without removable retractor.
PF	Packing Gland* stem seal, 2-inch 150 lb Flange process connection, 50 psig (3.5 barg) maximum process pressure without removable retractor.
PG	Packing Gland* stem seal, 2-inch 300 lb Flange process connection, 50 psig (3.5 barg) maximum process pressure without removable retractor.

Note: A retractor is recommended for hot tap installations with line pressures above 50psig

Feature 7: Process Connection (Packing Glands No Retractor DN)	
PFDR	Packing Gland* stem seal, DN50 PN16 Flange process connection, 50 psig (3.5 barg) maximum process pressure without removable retractor.
PGDR	Packing Gland* stem seal, DN50 PN40 Flange process connection, 50 psig (3.5 barg) maximum process pressure without removable retractor.

Note: A retractor is recommended for hot tap installations with line pressures above 50psig

Feature 7: Process Connection (Packing Glands No Retractor JIS)	
PMJ	Packing Gland* stem seal, 2-inch Male NPT process connection, JIS 30K pressure rating maximum process pressure without removable retractor.
PFJ	Packing Gland* stem seal, 2-inch JIS 10K Flange process connection, 50 psig (3.5 barg) maximum process pressure without removable retractor.
PGJ	Packing Gland* stem seal, 2-inch JIS 20K Flange process connection, 50 psig (3.5 barg) maximum process pressure without removable retractor.

Note: A retractor is recommended for hot tap installations with line pressures above 50psig

Feature 7: Process Connection (Packing Glands Retractor ANSI)	
PMR	Packing Gland stem seal, 2-inch NPT process connection with Retractor
PMHR	Packing Gland stem seal 2-inch NPT process connection with Heavy-Duty Retractor
PFR	Packing Gland stem seal, 2-inch 150 lb Flange process connection with Retractor
PGR	Packing Gland stem seal, 2-inch 300 lb Flange process connection with Retractor
PHR	Packing Gland stem seal, 2-inch 600 lb Flange process connection with Heavy-Duty Retractor
PIR	Packing Gland stem seal, 2-inch 900 lb Flange process connection with Heavy-Duty Retractor

Note: A retractor is recommended for hot tap installations with line pressures above 50psig

Feature 7: Process Connection (Packing Glands Retractor DN)	
PFDR	Packing Gland stem seal, DN50 PN16 Flange process connection with Retractor
PGDR	Packing Gland stem seal, DN50 PN40 Flange process connection with Retractor
PHDR	Packing Gland stem seal, DN50 PN63 Flange process connection with Heavy-Duty Retractor

Feature 7: Process Connection (Packing Glands Retractor JIS)	
PMJR	Packing Gland stem seal, 2-inch NPT. process connection with Retractor
PMJHR	Packing Gland stem seal 2-inch NPT process connection with Heavy-Duty Retractor
PFJR	Packing Gland stem seal, 2-inch JIS 10K Flange process connection with Retractor
PGJR	Packing Gland stem seal, 2-inch JIS 20K Flange process connection with Retractor
PHJR	Packing Gland stem seal, 2-inch JIS 30K Flange process connection with Heavy-Duty Retractor

Feature 7: Process Connection (Packing Glands Retractor ANSI Extended Length Probes)	
PMR-LE	**EL probe** Packing Gland stem seal, 2-inch NPT process connection with Retractor
PMHR-LE	**E: probe** Packing Gland stem seal 2-inch NPT process connection with Heavy-Duty Retractor
PFR-LE	**EL probe** Packing Gland stem seal, 2-inch 150 lb Flange process connection with Retractor
PGR-LE	**EL probe** Packing Gland stem seal, 2-inch 300 lb Flange process connection with Retractor
PHR-LE	**EL probe** Packing Gland stem seal, 2-inch 600 lb Flange process connection with Retractor
PIR-LE	**EL probe** Packing Gland stem seal, 2-inch 900 lb Flange process connection with Retractor

Feature 7: Process Connection (Packing Glands Retractor DN Extended Length Probes)	
PFDR-LE	**EL probe** Packing Gland stem seal, DN50 PN16 Flange process connection with Retractor
PGDR-LE	**EL probe** Packing Gland stem seal, DN50 PN40 Flange process connection with Retractor
PHDR-LE	**EL probe** Packing Gland stem seal, DN50 PN63 Flange process connection with Retractor

ORDERING THE 241S INSERTION (CONTINUED)

Feature 7: Process Connection (Packing Glands Retractor JIS Extended Length Probes)	
PMJR-LE	**EL probe** Packing Gland stem seal, 2-inch NPT JIS 30K pressure rating process connection with Retractor
PMJHR-LE	**EL probe** Packing Gland stem seal 2-inch NPT process connection with Heavy-Duty Retractor
PFJR-LE	**EL probe** Packing Gland stem seal, 2-inch JIS 10K Flange process connection with Retractor
PGJR-LE	**EL probe** Packing Gland stem seal, 2-inch JIS 20K Flange process connection with Retractor
PHJR-LE	**EL probe** Packing Gland stem seal

Option 1: Certification Documents			
MC	Material certificates--US Mill certs on all wetted parts	NC	NACE Certification
PT	Pressure Test Certificate	O2	Oxygen Cleaning
CC	Certificate of Conformance	CO	Certificate of Origin

Option 2: Remote Cable	
ARM25V	25 feet (7.6 m) Armored Cable R-With Glands (ATEX, IECEX) V meter only - Adder to Remote option
ARM50V	50 feet (17 m) Armored Cable R-With Glands (ATEX, IECEX) V meter only - Adder to Remote option
ARM25VTP	25 feet (7.6 m) Armored Cable R-With Glands (ATEX, IECEX) VT, VTP meter only - Adder to Remote option
ARM50VTP	50' (17 m) Armored Cable R-With Glands (ATEX, IECEX) VT, VTP meter only - Adder to Remote option



Measurably Different.®

Sierra Instruments

North America
 20 Ryan Ranch Rd, Suite 109
 Monterey, California 93940
 +1.831.373.0200 • sierrainstruments.com

Asia
 Second Floor Building 5 • Senpu Industrial Park • 25 Hangdu
 Road Hangtoun Town • Pu Dong New District • Shanghai, P.R.
 China 201316 • +8621 5879 8521/22

240S R 12/25

Appendix B Approvals

ATEX-IECEX Specifications / Approval

EN IEC 60079-0: 2018

Electrical Apparatus for explosive gas atmospheres
General Requirements

EN 60079-1:2014

Electrical Apparatus for explosive gas atmospheres
Flameproof enclosures “d”

EN 60079-31: 2014

Explosive atmospheres. Equipment dust ignition protection by enclosure "t"

EN 60529:1992+A2:2013

Degrees of protection provided by enclosures (IP Code)

Directive 2014/34/EU

Equipment Intended for use in Potentially Explosive Atmospheres (ATEX)

240S/241S, ST, w/ATEX and IECEX Label



240S/241S, HT, w/ATEX and IECEX Label

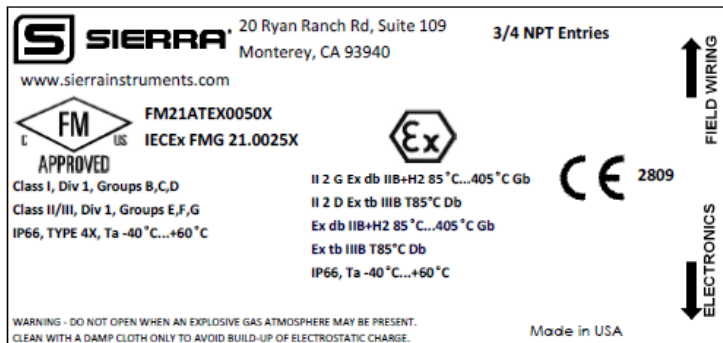



Declaration of Conformity

Sierra Instruments, Inc.
20 Ryan Ranch Road, Suite 109
Monterey, CA 93940

Declares in sole responsibility that the product:
Vortex Flow Meter Type: 240S / 241S

Conforms to the regulations of the European Directives:

EMC Directive 2014/30/EU
Low Voltage Directive 2014/35/EU
Pressure Equipment Directive 2014/68/EU
Explosion Protection Directive 2014/34/EU

Applied harmonized standards or normative documents:

EMC Directive 2014/30/EU

EN 61000-6-2: 2016	(immunity industrial environment)
EN 61000-6-3: 2021	(emission residential, commercial)
EN 61326-1: 2021	(electrical equipment for measurement, control, and laboratory use)
EN 55011: 2016+A2:2021	Group 1, Class A (ISM radio-frequency equipment)

Low Voltage Directive 2014/35/EU

EN 61010-1:2010+A1:2019 Safety requirements for electrical measuring, control and laboratory devices

Pressure Equipment Directive 2014/68/EU

Category I , Annex III, Module H	Full Quality Assurance
Article 4, Paragraph 3	Sound Engineering Practice
AD 2000 Merkblatter	Regulations for pressure vessel calculations

RoHS Directive 2011/65/EU

EN IEC 63000:2018 Technical assessment of electrical and electronic products with respect to RoHS

Explosion Protection Directive 2014/34/EU

EN IEC 60079-0: 2018	Electrical Apparatus for explosive gas atmospheres, General Requirements
EN 60079-1: 2014	Electrical Apparatus for explosive gas atmospheres, flameproof enclosures "d"
EN 60079-31: 2014	Explosive atmospheres. Equipment dust ignition protection by enclosure "t"
EN 60529:1992+A2:2013	Degrees of protection provided by enclosures (IP Code)

EC – Type Examination Certificate: FM 25ATEX0016X

Name and Address of the Notified Body

FM Approvals Europe Ltd
Element 78
1 Georges Quay Plaza
Dublin D02 E440, Ireland

TÜV – Industrie Service GmbH
TÜV SÜD Gruppe
Dudenstraße 28
D-68167 Mannheim



Steve Donjon

Quality Manager

Technical assistance may be obtained by contacting Customer Service at:
(831) 373-0200 in the USA

Appendix C Flow Meter Calculations

In-Line Flow Meter Calculations

Volume Flow Rate

$$Q_v = \frac{f}{K}$$

Flowing Velocity

$$V_f = \frac{Q_v}{A}$$

Mass Flow Rate

$$Q_M = Q_v \rho$$

Where:

A = Cross sectional area of the pipe (ft²)

f = Vortex shedding frequency (pulses / sec)

K = Meter factor corrected for thermal expansion (pulses / ft³)

Q_M = Mass flow rate (lbm / sec)

Q_v = Volume flow rate (ft³ / sec)

V_f = Flowing velocity (ft / sec)

ρ = Density (lbm / ft³)

Insertion Flow Meter Calculations

Flowing Velocity

$$V_f = \frac{f}{K_c}$$

Volume Flow Rate

$$Q_v = V_f A$$

Mass Flow Rate

$$Q_M = V_f A \rho$$

Where:

A = Cross sectional area of the pipe (ft²)

f = Vortex shedding frequency (pulses / sec)

K_c = Meter factor corrected for Reynolds Number (pulses / ft)

Q_v = Volume flow rate (ft³ / sec)

Q_M = Mass flow rate (lbm / sec)

V_f = Flowing velocity (ft / sec)

ρ = Density (lbm / ft³)

Energy Flow Calculations

Energy is calculated for a steam supply/condensate return or hot/chilled water system. For steam/water, the meter must be located in the supply line; otherwise, the meter may be located in either the supply line or in the return line.

Steam supply, water return, meter steam supply

$$\text{Energy} = \text{mdot} * (\text{h0} - \text{pctRet} * \text{h1})$$

Where:

mdot = mass flow at the meter, lbm/sec
 pctRet = estimated percent of mass flow returned
 h0 = Steam Enthalpy (t0, p)
 h1 = Water Enthalpy (t1)
 t0 = steam temperature
 t1 = return water temperature
 p = steam pressure

Water supply and return, meter supply

$$\text{Energy} = \text{mdot} * (\text{h0} - \text{pctRet} * \text{h1})$$

Where:

h0 = Water Enthalpy (t0)
 h1 = Water Enthalpy (t1)
 t0 = supply water temperature
 t1 = return water temperature

Water supply and return, meter return

$$\text{Energy} = \text{mdot} * (\text{h1}/\text{pctRet} - \text{h0})$$

Where:

h0 = Water Enthalpy (t0)
 h1 = Water Enthalpy (t1)
 t0 = return water temperature
 t1 = supply water temperature

The energy flow is positive if less energy is returned than is supplied. This implies that chilled water systems will indicate negative energy flow. Positive and negative energy flows are accumulated in separate totalizers.

Fluid Calculations

Calculations for Steam T & P

When “Steam T & P” is selected in the “Real Gas” selection of the Fluid Menu, the calculations are based on the equations below.

Density

The density of steam is calculated from the formula given by Keenan and Keys. The given equation is for the specific volume of the steam.

$$v = \frac{4.55504 (T)}{p} + B$$

$$B = B_0 + B_0^2 g_1(\tau) \tau \cdot p + B_0^4 g_2(\tau) \tau^3 \cdot p^3 - B_0^{13} g_3(\tau) \tau^{12} \cdot p^{12}$$

$$B_0 = 1.89 - 2641.62 \cdot \tau \cdot 10^{80870\tau^2}$$

$$g_1(\tau) = 82.546 \cdot \tau - 1.6246 \cdot 10^5 \cdot \tau^2$$

$$g_2(\tau) = 0.21828 - 1.2697 \cdot 10^5 \cdot \tau^2$$

$$g_3(\tau) = 3.635 \cdot 10^{-4} - 6.768 \cdot 10^{64} \cdot \tau^{24}$$

Where tau is 1/ temperature in Kelvin.

The density can be found from $1/v$ (specific volume of steam).

Viscosity

The viscosity is based on an equation given by Keenan and Keys.

$$\eta(\text{poise}) = \frac{1.501 \cdot 10^{-5} \sqrt{T}}{1 + 446.8/T}$$

Where T is the temperature in Kelvin

Calculations for Gas (“Real Gas” and “Other Gas”)

Use this formula to determine the settings for “Real Gas; Gas” selections and “Other Gas” selections entered in the Fluid Menu. The calculations for gas were taken from Richard W. Miller, *Flow Measurement Engineering Handbook (Third Edition, 1996)*.

Density

The density for real gases is calculated from the equation:

$$\rho = \frac{GM_{w,Air}P_f}{Z_f R_0 T_f}$$

Where G is the specific gravity, M_w is the molecular weight of air, p_f is the flowing pressure, Z is flowing compressibility, R_0 is the universal gas constant, and T is the flowing temperature.

The specific gravity, and R_0 are known and are stored in a table used by the Vortex meter.

The hard coefficient to find is the compressibility, Z. Z is found using the Redlich-Kwong Equation (Miller page 2-18).

The Redlich-Kwong Equation uses the reduced temperature and pressure to calculate the compressibility factor. The equations are non linear and an iterative solution is used. The Vortex program uses Newton’s Method on the Redlich-Kwong equations to iteratively find the compressibility factor. The critical temperature and pressure used in the Redlich-Kwong equation are stored in the fluid data table with the other coefficients.

Viscosity

The viscosity for real gases is calculated using the exponential equation for two known viscosities. The equation is:

$$\mu_{cp} = aT_K^n$$

Where a and n are found from two known viscosities at two temperatures.

$$n = \frac{\ln[(\mu_{cp})_2 / (\mu_{cp})_1]}{\ln(T_{K2} / T_{K1})}$$

and

$$a = \frac{(\mu_{cp})_1}{T_{K1}^n}$$

Calculations for Liquid

Use this formula to determine the settings for “Goyal-Dorais” selections and “Other Liquid” selections entered in the Fluid Menu. The liquid calculations were taken from Richard W. Miller, *Flow Measurement Engineering Handbook (Third Edition, 1996)*.

Density

The liquid density is found using the Goyal-Doraiswamy Equation. Goyal-Doraiswamy uses the critical compressibility, critical pressure and critical temperature, along with the molecular weight to find the density. The equation for specific gravity is:

$$G_F = \frac{p_c Mw}{T_c} \left(\frac{0.008}{Z_c^{0.773}} - 0.01102 \frac{T_f}{T_c} \right)$$

The specific gravity can then be converted into density.

Viscosity

The liquid viscosity is found by Andrade's equation. This uses two viscosities at different temperatures to extrapolate the viscosity.

Andrade's equation:

$$\mu = A_L \exp \frac{B_L}{T_{\text{deg R}}}$$

To find A and B

$$B_L = \frac{T_{\text{deg R}1} T_{\text{deg R}2} \ln(\mu_1 / \mu_2)}{T_{\text{deg R}2} - T_{\text{deg R}1}}$$

$$A_L = \frac{\mu_1}{\exp(B_L / T_{\text{deg R}1})}$$

The temperatures are all in degrees Rankin. Do not believe the subscript R means they are reduced temperatures.

Appendix D Glossary

A B C D

A	Cross sectional area.
ACFM	Actual Cubic Feet Per Minute (volumetric flow rate).
ASME	American Society of Mechanical Engineers.
Bluff Body	A non-streamlined body placed into a flow stream to create vortices. Also called a Shedder Bar.
BTU	British Thermal Unit, an energy measurement.
Cenelec	European Electrical Code.
Compressibility Factor	A factor used to correct for the non-ideal changes in a fluid's density due to changes in temperature and/or pressure.
CSA	Canadian Standards Association.
d	Width of a bluff body or shedder bar.
D	Diameter of a flow channel.

E F G H

f	Frequency of vortices generated in a vortex flow meter, usually in Hz.
Flow Channel	A pipe, duct, stack, or channel containing flowing fluid.
Flow Profile	A map of the fluid velocity vector (usually non-uniform) in a cross-sectional plane of a flow channel (usually along a diameter).
FM	Factory Mutual.
Ft	Foot, 12 inches, a measure of length.
Ft ²	Square feet, measure of area.
Ft ³	Cubic feet, measure of volume.
GPM	Gallons Per Minute.
Hz	Hertz, cycles per second.

I J K L

In-Line Flow Meter	A flow meter which includes a short section of piping which is put in-line with the user's piping.
Insertion Flow Meter	A flow meter which is inserted into a hole in the user's pipeline.
Joule	A unit of energy equal to one watt for one second. Also equal to a Newton-meter.
LCD	Liquid crystal display.

M N O P

\dot{m}	Mass flow rate.
mA	Milli-amp, one thousandth of an ampere of current.
μ	Viscosity, a measure of a fluid's resistance to shear stress. Honey has high viscosity, alcohol has low viscosity.
nm ³ /hr	Normal cubic meters per hour (flow rate converted to normal conditions, as shipped 101 kPa and 0° C). User definable.
ΔP	Permanent pressure loss.
P	Line pressure (psia or bar absolute).
ρ_{act}	The density of a fluid at the <u>actual</u> temperature and pressure operating conditions.
ρ_{std}	The density of a fluid at <u>standard</u> conditions (usually 14.7 psia and 20° C).
Permanent Pressure Loss	Unrecoverable drop in pressure.
Piezoelectric Crystal	A material which generates an electrical charge when the material is put under stress.
PRTD	An resistance temperature detector (RTD) with platinum as its element. Used because of high stability.
psia	Pounds per square inch absolute (equals psig + atmospheric pressure). Atmospheric pressure is typically 14.696 psi at sea level.
psig	Pounds per square inch gauge.
P _v	Liquid vapor pressure at flowing conditions (psia or bar absolute).

Q R S T

Q	Flow rate, usually volumetric.
Rangeability	Highest measurable flow rate divided by the lowest measurable flow rate.
Reynolds Number or Re	A dimensionless number equal to the density of a fluid times the velocity of the fluid times the diameter of the fluid channel, divided by the fluid viscosity (i.e., $Re = \rho VD/\mu$). The Reynolds number is an important number for vortex flow meters because it is used to determine the minimum measurable flow rate. It is the ratio of the inertial forces to the viscous forces in a flowing fluid.
RTD	Resistance temperature detector, a sensor whose resistance increases as the temperature rises.
scfm	Standard cubic feet per minute (flow rate converted to standard conditions, as shipped 14.696 psia and 59° F). User definable.
Shedder Bar	A non-streamlined body placed into a flow stream to create vortices. Also called a Bluff Body.
Strouhal Number or St	A dimensionless number equal to the frequency of vortices created by a bluff body times the width of the bluff body divided by the velocity of the flowing fluid (i.e., $St = fd/V$). This is an important number for vortex flow meters because it relates the vortex frequency to the fluid velocity.
Totalizer	An electronic counter which records the total accumulated flow over a certain range of time.
Traverse	The act of moving a measuring point across the width of a flow channel.

U V W X Y Z

Uncertainty	The closeness of agreement between the result of a measurement and the true value of the measurement.
V	Velocity or voltage.
VAC	Volts, alternating current.
VDC	Volts, direct current.
VORTEX	An eddy of fluid.

Appendix E Warranty Policy

Limited Warranty Policy – Register Online

All Sierra products are warranted to be free from defects in material and workmanship and will be repaired or replaced at no charge to Buyer, provided return or rejection of product is made within a reasonable period but no longer than one (1) year for calibration and non-calibration defects, from date of delivery. To assure warranty service, customers must register their products online on Sierra's website. Online registration of all of your Sierra products is required for our warranty process. Register now at www.sierrainstruments.com/register . Learn more about Sierra's warranty policy at www.sierrainstruments.com/warranty .