

# QuadraTherm® 640i/780i Series Insertion and In-Line Mass Flow Meters

## Instruction Manual



Part Number: IM-640i/780i Rev.V2.A  
October 2024



## GLOBAL SUPPORT LOCATIONS: WE ARE HERE TO HELP!

### CORPORATE HEADQUARTERS

20 Ryan Ranch Road, Suite 109  
Monterey, CA 93940  
Phone (831) 373-0200  
[www.sierrainstruments.com](http://www.sierrainstruments.com)

### EMEA HEADQUARTERS

Bijlmansweid 2 1934RE Egmond aan den Hoef  
The Netherlands  
Phone +31 72 5071400

### ASIA HEADQUARTERS

Second Floor Building 5, Senpu Industrial Park  
25 Hangdu Road Hangtoun Town  
Pu Dong New District, Shanghai, P.R. China  
Postal Code 201316  
Phone: + 8621 5879 8521

### IMPORTANT CUSTOMER NOTICE- OXYGEN SERVICE

Sierra Instruments, Inc. is not liable for any damage or personal injury, whatsoever, resulting from the use of Sierra Instruments standard mass flow meters for oxygen gas. You are responsible for determining if this mass flow meter is appropriate for your oxygen application. You are responsible for cleaning the mass flow meter to the degree required for your oxygen flow application.

### © COPYRIGHT SIERRA INSTRUMENTS 2024

No part of this publication may be copied or distributed, transmitted, transcribed, stored in a retrieval system, or translated into any human or computer language, in any form or by any means, electronic, mechanical, manual, or otherwise, or disclosed to third parties without the express written permission of Sierra Instruments. The information contained in this manual is subject to change without notice.

### TRADEMARKS

QuadraTherm®, qTherm®, and iAnywhere™ are trademarks of Sierra Instruments, Inc. Other product and company names listed in this manual are trademarks or trade names of their respective manufacturers.

## Operating Instructions - QuadraTherm 640i/780i Meters

This manual is for the latest version of the QuadraTherm® that is easily distinguishable from the earlier version by the flat membrane keypad and additional two LED's visible thru the glass.



# Table of Contents

<b>Chapter 1: Introduction &amp; Product Description</b> .....	5
Technical Assistance .....	7
Principle of Operation .....	8
qTherm™ Electronics Features .....	9
Enclosure Options .....	10
<b>Chapter 2: Installation &amp; Wiring</b> .....	11
Installation Overview .....	11
Installing the Flow Meter.....	13
Cold Tap Installation .....	13
Hot Tap Installation .....	14
Wiring Connections – Protection of Your Meter.....	16
Wiring Connections - General .....	18
Alarm Output Wiring.....	22
Remote Sensor Wiring .....	24
<b>Chapter 3: Operation &amp; Programming</b> .....	27
Start-up Routine.....	28
Level 1: Main Menu.....	28
Level 2: Sub-Menu (Password Protected).....	31
Table 3-2: Level 2 Sub-Menu .....	31
Calibration (Sub-Menu) .....	31
Calibration (Sub-Menu): Gas Type –“qTherm Dial-A Gas” .....	32
Calibration (Sub-Menu): Flow Units .....	34
Calibration (Sub-Menu): Temperature Units.....	35
Calibration (Sub-Menu): Span Adjust.....	36
Calibration (Sub-Menu): % FS Cutoff.....	36
Process Pressure (Sub-Menu): Pressure Units.....	39
Process Pressure Sub-Menu: Process Pressure .....	40
Totalizer (Sub-Menu) .....	40
Totalizer Sub-Menu: Reset Pulse Count.....	41
Totalizer (Sub-Menu): Units Per Pulse.....	42
Totalizer (Sub-Menu): Totalizer On/Off .....	43
Output Adjust (Sub-Menu): Flow, Pressure and Temperature .....	46
Setting Up 4 to 20 mA for Temperature and Pressure .....	48
Reference Conditions (Sub-Menu): Standard and Normal.....	49
<b>Chapter 4: Troubleshooting &amp; Repair</b> .....	52
Troubleshooting the Flow Meter.....	52
Returning Equipment to Factory.....	54
<b>Appendix A: Product Specification</b> .....	55
<b>Appendix B: Smart Interface Installation</b> .....	66
<b>Appendix C: Warranty Policy</b> .....	91

# Warnings and Cautions



**Warning!** Agency approval for hazardous location installations varies between flow meter models. Consult the flow meter nameplate for specific flow meter approvals before any hazardous location installation.

**Warning!** Hot tapping must be performed by a trained professional. U.S. regulations often require a hot tap permit. The manufacturer of the hot tap equipment and/or the contractor performing the hot tap is responsible for providing proof of such a permit

**Warning!** All wiring procedures must be performed with the power off.

**Warning!** To avoid potential electric shock, follow National Electric Code safety practices or your local code when wiring this unit to a power source and to peripheral devices. Failure to do so could result in injury or death. All AC power connections must be in accordance with published CE directives.

**Warning!** Do not power the flow meter with the sensor remote (if applicable)wires disconnected. This could cause over-heating of the sensors and/or damage to the electronics.

**Warning!** Before attempting any flow meter repair, verify that the line is de-pressurized.

**Warning!** Always remove main power before disassembling any part of the mass flow meter.



**Caution!** Before making adjustments to the device, verify the flow meter is not actively monitoring or reporting to any master control system. Adjustments to the electronics will cause direct changes to flow control settings.

**Caution!** All flow meter connections, isolation valves and fittings for hot tapping must have the same or higher pressure rating as the main pipeline.

**Caution!** Changing the length of cables or interchanging sensors or sensor wiring will affect the accuracy of the flow meter. You cannot add or subtract wire length without returning the meter to the factory for re-calibration.

**Caution!** When using toxic or corrosive gases, purge the line with inert gas for a minimum of four hours at full gas flow before installing the meter.

**Caution!** The AC wire insulation temperature rating must meet or exceed 80°C (176°F).

**Caution!** Printed circuit boards are sensitive to electrostatic discharge. To avoid damaging the board, follow these precautions to minimize the risk of damage:

- before handling the assembly, discharge your body by touching a grounded, metal object
- handle all cards by their edges unless otherwise required
- when possible, use grounded electrostatic discharge wrist straps when handling sensitive components

# Chapter 1: Introduction & Product Description

From Sierra's beginning over fifty years ago, Founder Dr. John G. Olin was driven by the vision of supplying industrial customers with the world's most accurate thermal mass flow meter. And, he knew it was a "sensor" game.

The development of an industrialized metal-sheathed sensor in the early 80s was Sierra's first big step, but Dr. Olin is a driven innovator, and this was only the beginning for someone who saw "Thermal Mass Flow" as his life's work. Many successful innovations followed, but in 1999 Sierra experienced a major breakthrough with the introduction of their patented no-drift DrySense™ thermal mass velocity sensor. Sierra engineers now recognized they were on the cusp of realizing Dr. Olin's vision.

**Realizing the Vision:** Thermal technology, by its very nature, uses the physics of heat transfer and conservation of energy in a closed system to measure mass flow rate. This means that for a thermal mass flow meter to achieve the greatest accuracy, it must solve the First Law of Thermodynamics (Heat Energy In = Heat Energy Out) for each data point.

As you can imagine, solving the First Law in a flow instrument was no easy task. By Dr. Olin's own accounting, decades of "hard-nosed dedication to excellence" by himself and Sierra's engineering team, years of testing, and his stack of yellow note pads over five feet high, jammed with his handwritten equations and designs, finally yielded the secret in the form of two revolutionary technologies—QuadraTherm™ and qTherm™, now both patented worldwide.

**The QuadraTherm Sensor:** Traditional thermal sensors have two sensors—one temperature sensor and one velocity sensor, each in a separate probe. QuadraTherm (the term "Quad" meaning "four") introduces four sensors—three precision platinum temperature sensors and one patented DrySense mass velocity sensor. Performance improvements never before possible are gained as the QuadraTherm Technology isolates forced convection (the critical variable for measuring gas mass flow rate) by calculating and then eliminating unwanted heat-transfer components, like sensor stem conduction, one of the major causes of false flow readings.

**qTherm, the Brains Behind it:** qTherm is the true "Brain" of the instrument and a revolutionary, living, learning algorithm set made possible by today's hyper-fast microprocessors and QuadraTherm sensor inputs. qTherm manages changes in gas flow, temperature and pressure, as well as outside temperature, via a comprehensive heat-transfer model. The result of qTherm is a proprietary, fundamentally different gas mass flow rate calculation using all pertinent variables for the most precise, stable and accurate mass flow measurement possible.

## Website & Downloads

QuadraTherm <https://www.sierrainstruments.com/products/quadratherm.html>

Download this manual: <https://www.sierrainstruments.com/userfiles/file/manuals/640i-780i-instruction-manual.pdf>

## ***Features and Benefits***

- Accuracy (air) +/- 0.5% of reading from 50% to 100% of full scale  
+/-0.5% of reading plus 0.5% of full scale from 0% to 50% of full scale
- Patented vastly improved thermal sensor element for high accuracy
- Patented DrySense™ Technology for long term drift stability; lifetime warranty
- Instrument-optimized proprietary qTherm Gas Library for application independence
- Sensor design improvements to eliminate downdraft effects from probe
- Dial-A-Gas®: change gas and engineering units in the field, on the fly with the push of a button
- Dial-A-Pipe™: Use insertion version on different pipe sizes, set up on the fly with the push of a button
- Multivariable: simultaneous measurement of mass flow rate, process temperature, and pressure

## ***Agency Approvals***

QuadraTherm® has a full-global suite of agency approvals for safe operation in potentially hazardous environments:

- cFMus (USA and Canada)
- ATEX (European Union)
- IECEX (International)
- CE Certified
- CRN Approval
- Manufactured under ISO-9001:2015

The 640i/780i is certified as flame-proof, protected from dust ignition sources, and meets all the design criteria for electrically-powered flow meters used in areas where combustible gases may be present. In short, now we are approved for safety in hazardous and potentially explosive plant environments and applications like facilities management, chemical processing, oil & gas, wastewater, and natural gas.

## ***Using This Manual***

This manual provides information needed to install and operate QuadraTherm 640i and 780i thermal mass flow meters. The four chapters and three appendices of this manual cover the following areas:

- Chapter 1: Introduction & Product Description
- Chapter 2 Installation & Wiring
- Chapter 3: Operation & Programming
- Chapter 4: Troubleshooting & Repair
- Appendix A: Product Specifications
- Appendix B: Smart Interface Program (SIP) software
- Appendix C: Warranty Policy

## **Note and Safety Information**

We use caution and warning statements throughout this book to draw your attention to important information.



### **Warning!**

This statement appears with information that is important to protect people and equipment from damage. Pay very close attention to all warnings that apply to your application.



### **Caution!**

This statement appears with information that is important for protecting your equipment and performance. Read and follow all cautions that apply to your application.

## **Receipt of System Components**

When receiving a Sierra mass flow meter, carefully check the outside packing carton for damage incurred in shipment. If the carton is damaged, notify the local carrier and submit a report to the factory or distributor. Remove the packing slip and check that all ordered components are present. Make sure any spare parts or accessories are not discarded with the packing material. Do not return any equipment to the factory without first contacting Sierra Customer Service.

## **Technical Assistance**

If you encounter a problem with your flow meter, review the configuration information for each step of the installation, operation, and setup procedures. Verify that your settings and adjustments are consistent with factory recommendations. Refer to Chapter 4: Troubleshooting, for specific information and recommendations.

If the problem persists after following the troubleshooting procedures outlined in Chapter 4, contact Sierra Instruments by fax or by E-mail (see inside front cover). For urgent phone support you may call (800) 866-0200 or (831) 373-0200 between 8:00 a.m. and 5:00 p.m. PST. In Europe, contact Sierra Instruments Europe at +31 72 5071400. In the Asia-Pacific region, contact Sierra Instruments Asia at + 8221 5879 8521. When contacting Technical Support, make sure to include this information:

- The flow range, serial number, and Sierra order number (all marked on the meter nameplate)
- The software version (visible at start up)
- The problem you are encountering and any corrective action taken
- Application information (gas, pressure, temperature and piping configuration)

## Principle of Operation

Watch a principal of operation video at [www.sierrainstruments.com/thermalprincipal](http://www.sierrainstruments.com/thermalprincipal)

Sierra's unique QuadraTherm™ sensor probe is responsible for the unsurpassed accuracy, ruggedness, and reliability of Sierra industrial flow meters. The immersible sensor consists of four sensing elements—a velocity sensor, a temperature sensor, and two stem conduction sensors that measure heat lost to the outside.

When power is applied to the flow meter, the transducer electronics heats the velocity sensor to a constant temperature differential above the gas temperature and measures the cooling effect of the gas flow. The electrical power required to maintain a constant temperature differential is directly proportional to the gas mass flow rate. The two stem conduction sensors ensure that any heat lost is due to this cooling effect, and not due to conduction to the outside.

The velocity sensor is a reference-grade platinum resistance temperature detector (RTD). The platinum RTD wire is wound on a rugged ceramic mandrel for strength and stability. The temperature sensor is clad in 316 stainless steel. The velocity sensor is clad in a Pt/Ir Alloy.

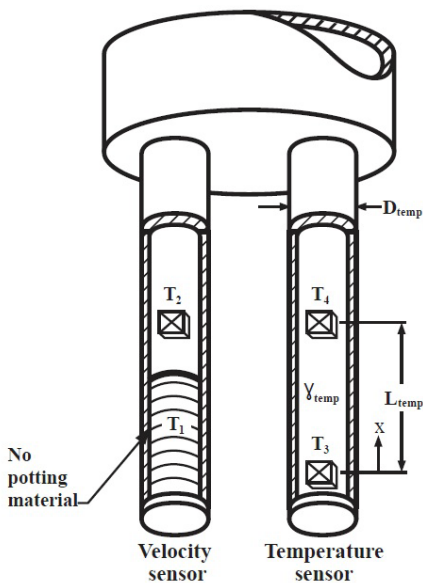

Figure 1-1:640i & 780i Series Sensor Assembly



## **qTherm™ Electronics Features**

### **qTherm™ Dial-A-Gas™ Technology**

Select gas to be measured

### **qTherm™ Dial-A-Pipe™ Technology**

Set-up pipe dimensions

### **Units**

Select units for mass flow, temperature, and pressure

### **User Full Scale Flow Rate**

Field-configure from 50% to 100% of the factory full scale setting

### **Alarms**

Program high & low or window alarm limits independently for mass flow, temperature, pressure and totalizer (select one)

### **MeterTune™ (Span Adjust)**

Change the calibration correction factor to compensate for flow profile disturbances or specific application conditions. The MeterTune™ (span adjust) is a multiplication factor applied to the flow signal

### **Dual Output Signals**

Two 4-20mA separate linear output signals proportional to flow and temperature. Optional 4-20mA proportional to pressure if pressure option selected.

### **Totalizer**

Set up totalizer pulse output

### **Set Standard Conditions**

Chose between, normal, standard and other

### **Set Password**

Set user password

### **Set Low Flow Cut-off**

Force flow to zero at a specified flow rate

### **View Tag Number**

View assigned tag number

**Set Language**

Set language for display

**View Communications Protocol Parameters**

View communications settings: 38,400 Baud rate, no parity, 8 data bits, and 1 stop Bit

**ValidCal™ Diagnostics**

Review minimum, maximum flow, temperature and pressure and other diagnostics

***Enclosure Options***

Flow meter electronics are available mounted directly to the flow body, or remotely mounted up to 100 feet (30 meters) away. The electronics' housing may be used indoors or outdoors.

Display options include a programmable LCD displaying mass flow, temperature, pressure, totalized flow, Dial-A-Gas, Dial-A-Pipe, MeterTune, and user full scale along with alarm, reference conditions, serial numbers and tag number. Local operation and re-configuration is accomplished using the push buttons on the device. Electronics include non-volatile memory that stores all configuration information. The memory allows the flow meter to function immediately upon power up, or after an interruption in power.

# Chapter 2: Installation & Wiring

## Installation Overview

The 640i and 780i are easy to set up in the field. The flow meter should be inserted to the centerline of the pipe.

When selecting an installation site, make sure that:



### Warning!

Agency approval for hazardous location installations varies between flow meter models. Consult the flow meter nameplate for specific flow meter approvals before any hazardous location installation.

1. Line pressure and temperature will not exceed the flow meter rating. If ambient temperature exceeds 50°C, remove flow meter to a cooler area.
2. The location meets the required minimum number of pipe diameters upstream and downstream of the sensor head (see Figure 2-1 on the next page)
3. Safe and convenient access with adequate clearance. Also, verify the meter is located where the gas is clean and dry.
4. Verify that the cable entry into the instrument meets the FM standard (if required).
5. For remote installations, verify the supplied cable length is sufficient to connect the flow meter sensor to the remote electronics. (Do not extend or shorten the supplied cable between the probe and the electronics.)
6. Also, before installation check your flow system for anomalies such as:
  - Leaks
  - Valves or restrictions in the flow path that could create disturbances in the flow profile that might cause unexpected flow rate indications
  - Heaters that might cause rapid excursions in the measured temperature

## Unobstructed Flow Requirements

Select an installation site that will minimize possible distortion in the flow profile. Valves, elbows, control valves and other piping components may cause flow disturbances. Check your specific piping condition against the examples shown below. In order to achieve accurate and repeatable performance, install the flow meter using the recommended number of straight run pipe diameters upstream and downstream of the sensor.

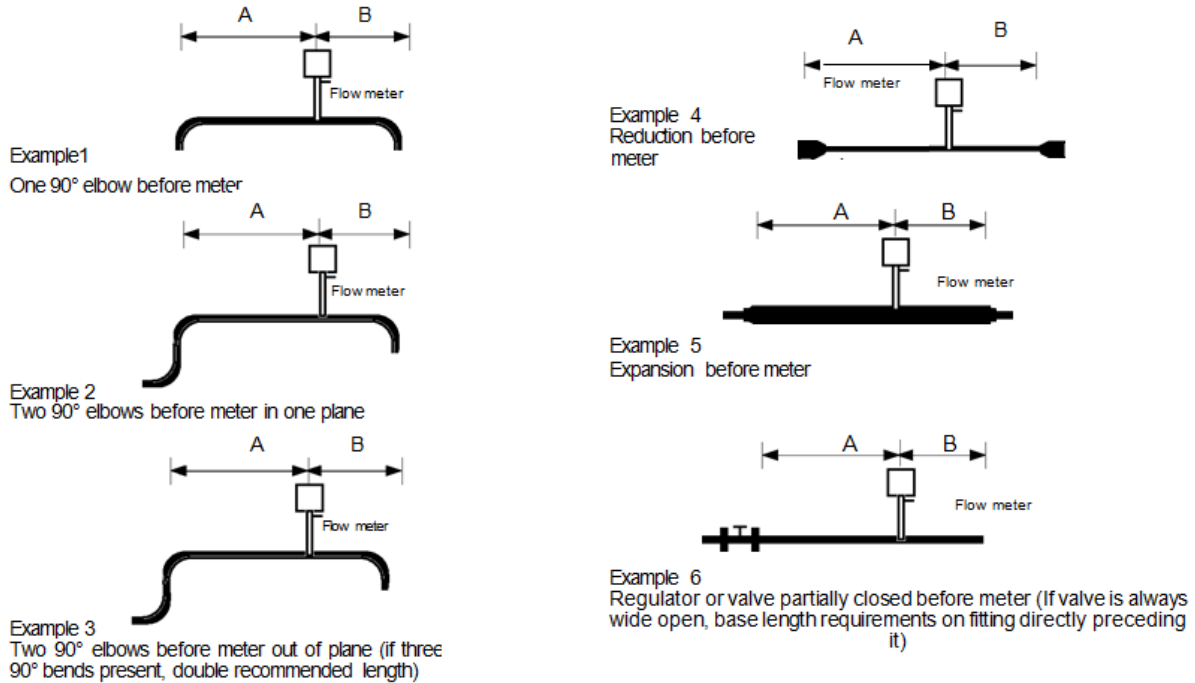

640i and 780i Straight Run Requirements				
Piping Condition Example	A-Upstream 640i Insertion <sup>(1)</sup>	A-Upstream 780i Inline with Flow Conditioning <sup>(1)</sup>	B- Downstream <sup>(2)</sup> 640i	B- Downstream <sup>(2)</sup> 780i
1	15D	1D	1D	0D
2	20D	3D	3D	0D
3	40D	3D	3D	0D
4	15D	3D	3D	0D
5	30D	3D	3D	0D
6	40D	5D	5D	0D
(1) Number of diameters (D) of straight pipe required between upstream disturbance and the flow meter				
(2) Number of diameters (D) of straight pipe required downstream of the flow meter				

Figure 2-1: Recommended Pipe Length Requirements for Installation

## Installing the Flow Meter

When positioning the flow meter, refer to the flow direction indicator attached to the probe. For proper operation, install the meter with the flow direction indicator pointing downstream in the direction of flow. Installing the meter opposite this direction will result in inaccurate flow measurement

## Cold Tap Installation



### Caution!

When using toxic or corrosive gases, purge the line with inert gas for a minimum of four hours at full gas flow before installing the flow meter.

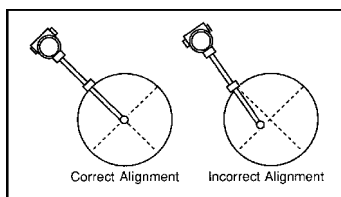

**NOTE:** Probe may enter the pipe from any direction as long as the tips are in the center.

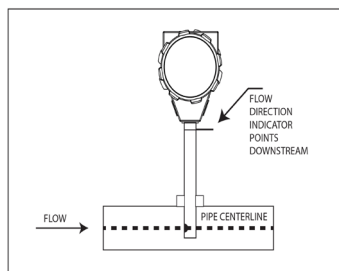

1. Confirm that the installation site meets the minimum upstream and downstream pipe diameter requirements shown in Figure 2-1 and that the ID of the pipe is at least 2 inches.
2. **Turn off the flow of process gas. Verify that the line is not pressurized.**
3. Use a cutting torch or sharp cutting tool to tap into the pipe. The pipe opening must be at least 0.78 inches in diameter. (Do not attempt to insert the sensor probe through a smaller hole.)
4. Remove all burrs from the tap. Rough edges may cause flow profile distortions that could affect flow meter accuracy. Also, obstructions could damage the sensor assembly when inserting into the pipe.
5. Mount the compression or flange fitting on the pipe. Make sure this connection is within  $\pm 5^\circ$  perpendicular to the pipe centerline as shown at left.
6. When installed, cap the fitting. Run a static pressure check on the connection. If pressure loss or leaks are detected, repair the connection and re-test.
7. Insert the sensor probe through the compression or flange fitting into the pipe. The correct insertion depth places the centerline of the sensor tips at the pipe's centerline. Take great care not to push the probe tips into the opposite inside of the pipe, or to have it inserted so far that it will push against it when the compression fitting is installed.
8. Align the sensor head using the flow direction indicator. Adjust the indicator parallel to the pipe pointing downstream in the direction of flow.
9. Tighten the fitting to lock the flow meter in position. (When a compression fitting is tightened, the position is permanent unless using Teflon ferrules.)



**Warning!**

Hot tapping must be performed by a trained professional. U.S. regulations often require a hot tap permit. The manufacturer of the hot tap equipment and/or the contractor performing the hot tap is responsible for providing proof of such a



**Caution!**

All flow meter connections, isolation valves and fittings for hot tapping must have the same or higher pressure rating as the main pipeline.

## Hot Tap Installation

When positioning the flow meter, refer to the flow direction indicator attached to the probe. For proper operation, install the meter with the flow direction indicator pointing downstream in the direction of flow. Installing the meter opposite this direction will result in inaccurate flow measurement. Low pressure hot taps cannot exceed 150 psig (10.3 barg) maximum. High pressure hot tap max pressure is flange dependent up to 400 psig (27.6 barg). Make sure the pipe pressure does not exceed these limits before beginning this procedure.

1. Confirm that the installation site meets the minimum upstream and downstream pipe diameter requirements shown in Figure 2-1.
2. Calculate the flow meter insertion depth as shown in Figure 2-2 for a low pressure tap or Figure 2-3 for a high pressure tap.
3. Weld the process connection on the pipe. Make sure the process connection is within  $\pm 5^\circ$  perpendicular to the pipe centerline (see previous page). The pipe opening must be at least 0.88 inches (22 mm) in diameter.
4. Bolt an isolation valve on the process connection. The valve's full open bore must be at least 0.88 inches (22 mm) in diameter.
5. Hot tap the pipe.
6. Close the isolation valve. Run a static pressure. If pressure loss or leaks are detected, repair the connection and re-test.
7. Insert the sensor probe through the isolation valve into the pipe with the flow direction indicator parallel to the pipe pointing downstream in the direction of flow. The correct insertion depth places the sensor at the pipe's centerline. Do not force into the pipe. The center of the flow sensor is defined as 0.5" up from the tip of the post which protects the sensor elements from damage.
8. Tighten the fittings to lock the flow meter in position.

## Calculating Insertion Depth for a Low Pressure Tap

### 640i Insertion Low Pressure Hot Tap To 150 psig (10.3 barg)

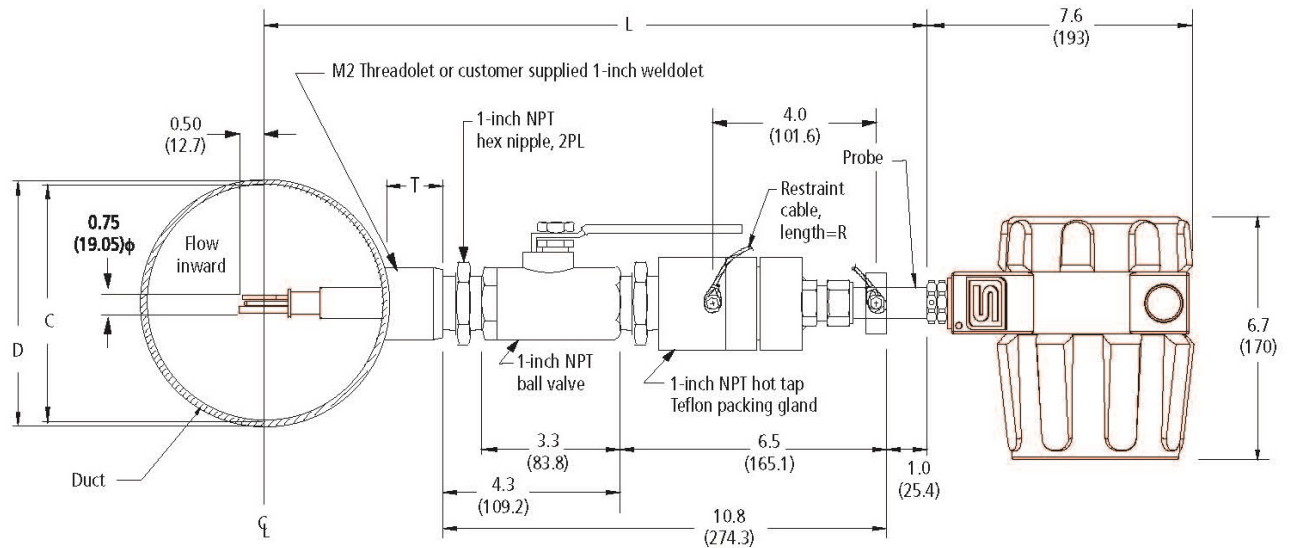

#### Variables

$L$  = Nominal Probe Length

$D$  = Duct O.D.

$C$  = Duct I.D.

$T$  = Height of "Threadolet" or Customer Provided Weldolet

$R$  = Restraint Cable Length

#### Formulas

$$L > 12.3 + T + D/2$$

So  $L$  must be equal or greater than 12.3-inches plus the height of the "Threadolet" plus half the duct O.D.

$$R = D/2 + T + 7.3$$

Figure 2-2: Low Pressure Tap Insertion Depth

## Calculating Insertion Depth for a High Pressure Tap

640i High Pressure Hot Tap Max Pressure is Flange Dependent Up to 400 psig (27.6 barg)

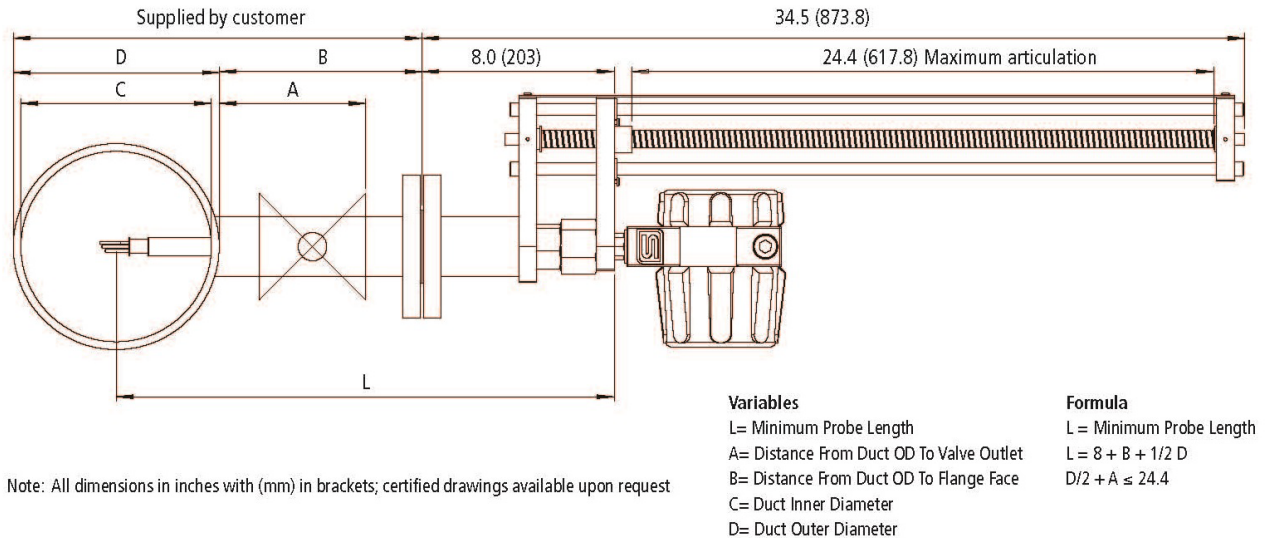

Figure 2-3. High Pressure Tap Insertion Depth



**Warning!**  
Failure to adhere to these guidelines may result in water damage that is not covered under Sierra's [Warranty Policy](#).

### Wiring Connections – Protection of Your Meter

To protect your investment and be certain of a long reliable service life, we have compiled some guidelines (from experience) that will aid your installation team in properly protecting the electronics from the application environment. These instruments have been designed for and proven reliable in some of the most extreme process conditions in industry: Mining, Oil and Gas, Water, Wastewater etc. The key however is to follow best practices to insure a proper seal to protect the internal components of this precision instrument.

Water penetration can lead to a damaged flow meter. Sierra's "E" HALE ex-proof enclosures are rated to a NEMA4X, IP66 rating. This provides protection against, rain, sleet, snow and splashing water, but water can damage the sensor, electronics or wiring terminals if the meter is not properly installed and maintained.

To minimize the potential for water damage, Sierra Instruments recommends the following:

- Install conduit seals near the enclosures on all ports.
- Use a cable gland design that provides shielded cable termination and an environmental seal against dirt and water.
- Do not bend, kink, or otherwise distort the cable at the entry points to the cable glands.



- Route conduit or cable using a drip loop or drain as close as possible to the enclosure ports unless the cable slopes directly down.
- If the factory cable glands are replaced to install other adapter fittings, conduit fittings, cable glands, or any other modification to the cable entry points be sure to use a good quality thread sealant on all NPT threads as well as verifying they are all tightened and sealed appropriately so as not to leak.
- Be certain to use NPT threads when connecting to the housing. Some electrical fittings are not tapered but will fit in the NPT ports of the enclosure. Sufficient Teflon tape and pipe dope is recommended to insure a leak tight seal.
- If you are uncertain of the conditions the interior of the housing is subjected to over time, a small temporary datalogger can be placed in the housing to record temperature and humidity to establish a baseline. Corrective action can be made based on this data before instrument degradation sets in. Contact Sierra Instruments for suggested sources of small dataloggers.
- Keep the enclosure lids sealed tight using the supplied o-rings.
- As part of the lid o-ring inspections look for any signs of condensation inside of the enclosure. If condensation or signs of condensation/corrosion are found be sure all fittings/seals are securely tightened as well as a desiccant bag can be used and replaced as needed. This can be particularly important if the temperature is cycled.

## Wiring Connections - General



### Warning!

To avoid potential electric shock, follow National Electric Code safety practices or your local code when wiring this unit to a power source and to peripheral devices. Failure to do so could result in injury or death. All AC power connections must be in accordance with published CE directives.

Use the terminal blocks located inside the cap of the flow meter enclosure for all wiring connections. Make sure to observe all CE compliance requirements for AC wiring connections given on the next page.

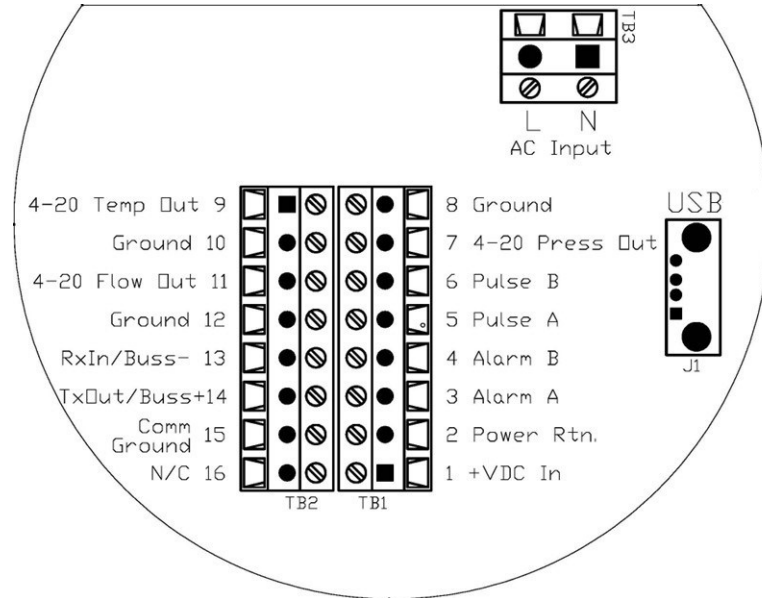

FIGURE 2-4  
WIRING ACCESS

Figure 2-4. Wiring Access

## Input Power Wiring



### Warning!

All wiring procedures must be performed with the power Off.



### Caution!

The AC wire insulation temperature rating must meet or exceed 80 °C (176°F).



Note: AC power must be ordered at the factory. DC units cannot be powered with AC.

### AC Power Wiring

The AC power wire size must be 26 to 16 AWG with the wire stripped 1/4 inch (6 mm). Connect 100 to 240 VAC (0.4 Amps RMS at 230 VAC) to the Neutral and Line terminals on the terminal block. Connect the ground wire to the safety ground lug. Torque all connections to 4.43 to 5.31 in-lbs (0.5 to 0.6 Nm).

The Hazardous-Area enclosure has two separate conduit entries to maintain separation between AC input power and output signal wiring. To eliminate the possibility of noise interference, use a separate cable entry for the AC power and signal lines.

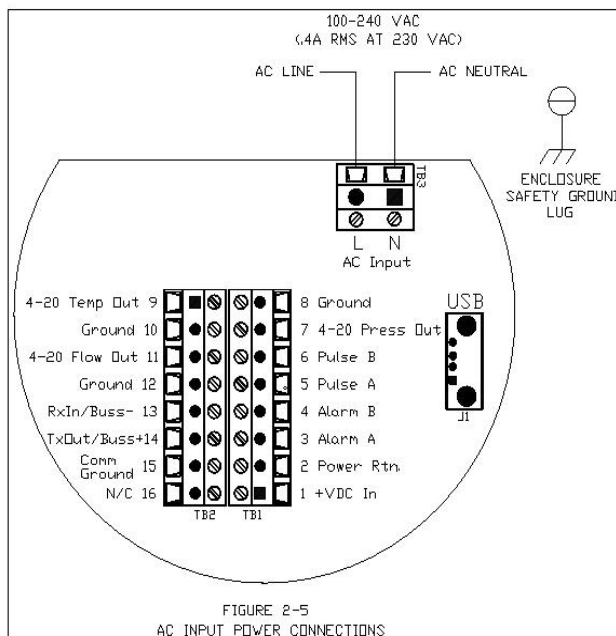

Figure 2-5: AC Input Power Connections

**Warning!**  
 All wiring procedures must be performed with the power Off.

### DC Power Wiring

The DC power wire size must be 26 to 16 AWG with the wire stripped 1/4 inch (6 mm). Connect 24 VDC +/- 10% (1.04A load, maximum) to the terminals marked on the terminal block. **\*\*IMPORANT\*\*** Connect an Earth ground wire to either the internal or external ground lug to protect against EMI/RFI/ESD interference or damage, and to assure proper operation. Note: Probe to pipe connection is not a reliable Earth ground. Torque all connections to 4.43 to 5.31 in-lbs (0.5 to 0.6 Nm).

If conduit seals are used, they must be installed within 18 inches of the enclosure.

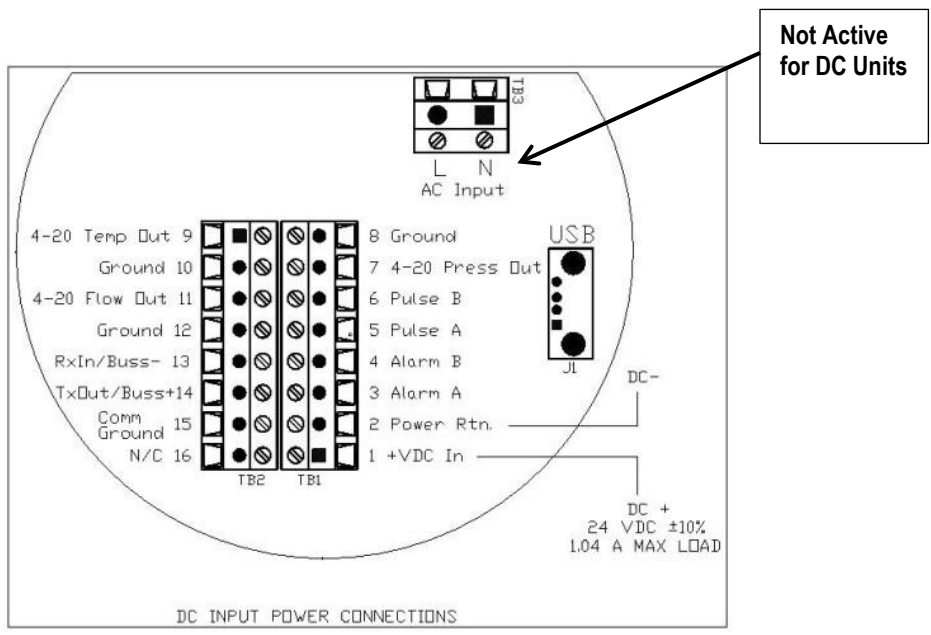

Figure 2-6: DC Input Power Connections



**Warning!**

Do not externally power the 4-20mA output loop. It is a self-powered loop.

### Output Signal Wiring

Output signal cable should be completely screened with a 100% shield. You must use metal cable glands that provide cable screen clamping. The cable screen should be connected to the gland and shielded at both ends over 360 degrees. The shield should be terminated to an earth ground. For all installations not using metal conduit it is recommended but not required that two ferrite beads should be added, one on each end of the I/O cable. This is to enhance CE related EMI/RFI protection. Good quality (Highest impedance at 100MHz) Broadband ferrites should be used, a solid cylindrical ferrite (recommended) usually has better performance than a clamp on ferrite. The ferrites should fit as tight as possible to the OD of your cable.

All QuadraTherm 640i/780i Series flow meters are equipped with calibrated 4-20 mA output signals for both flow and temperature, with an optional 4-20 MA output for pressure.

### 4-20 mA Output Wiring



Note: Do not externally power the 4-20mA output loop. It is a self-powered loop.

The 4-20 mA current loop output is non-isolated. Max load 500 ohms. Meter's output is sourced, and is not able to be configured as sinked.

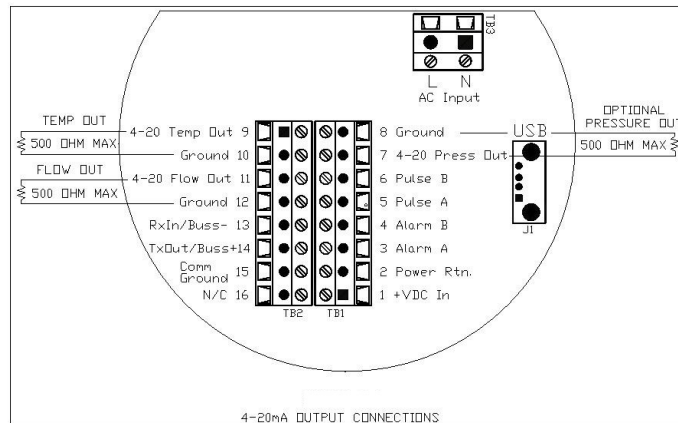

Figure 2-7: 4-20mA Output Connections

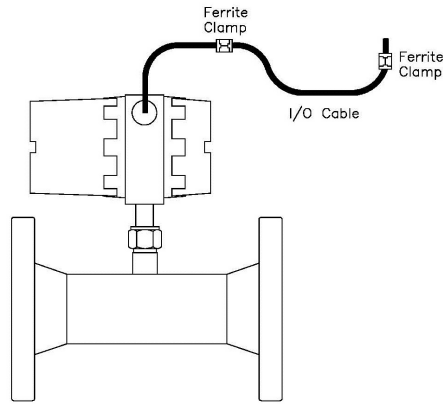

Figure 2-8 Recommended Ferrite Installation (Ferrite not required for conduit)

## Alarm Output Wiring

One alarm output contact is included on the flow meter terminal block. The alarm output is driven by an optical relay that is normally-open single-pole.

The relay is isolated and requires a separate power supply (isolated) the voltage of the alarm output is the same as the voltage supplied to the circuit.

To use an external power supply for an isolated alarm output, connect as shown in Figure 2-9. You may set low, high or window alarms for temperature, pressure, totalizer or mass flow.

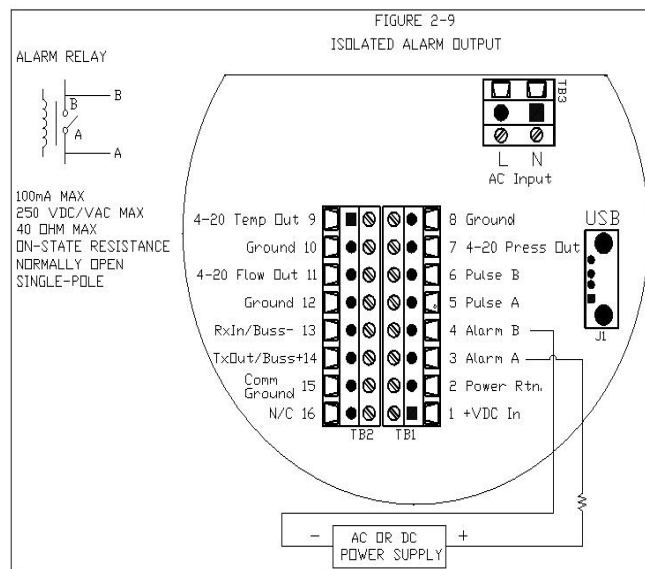

Figure 2-9: AC or DC Power Supply

## RS-232 Wiring

RS-232 provides serial communication. Wire per figure 2-10.

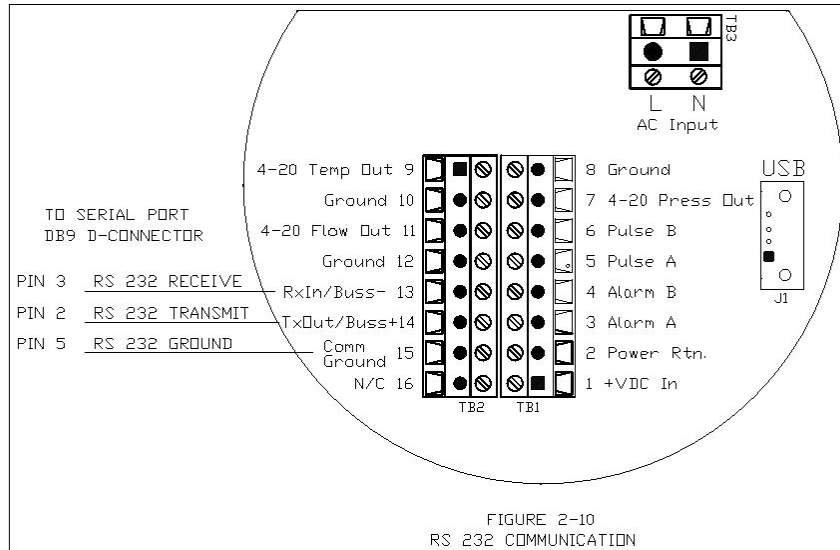

Figure 2-10: RS-232 Communication

## Pulse Output

QuadraTherm provides an adjustable pulse output with a maximum of 1 Hz. Wire per figure 2-11 below.

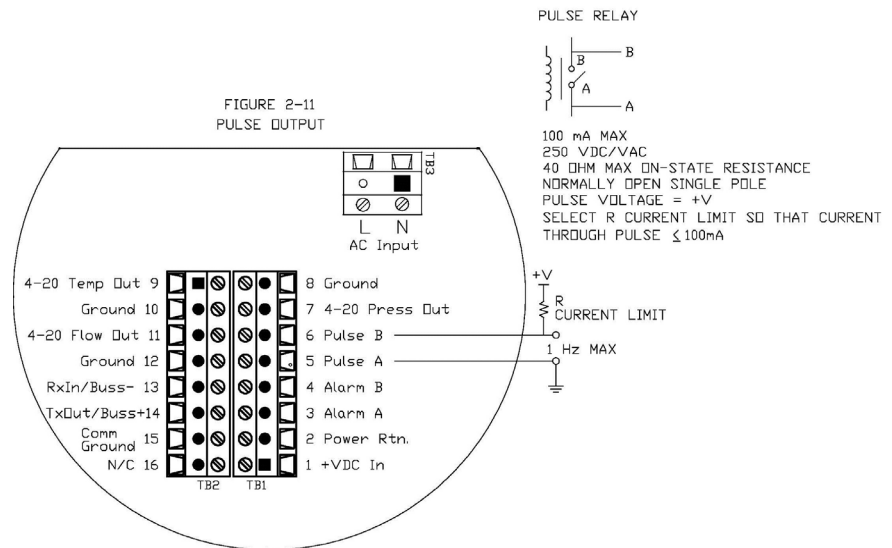

Figure 2-11: Pulse Output

## USB Output

If supplied, plug your USB cable into J1, per figure 2-12 .

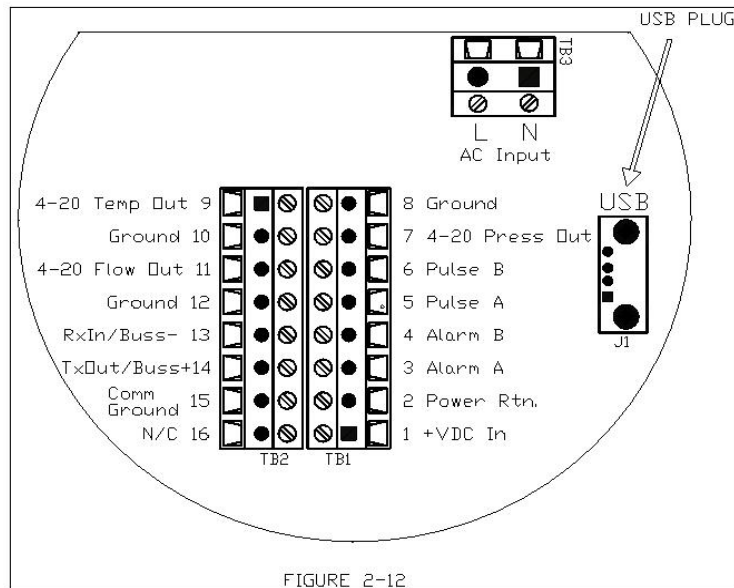

Figure 2-12: USB Output

## Remote Sensor Wiring

When connecting the sensor probe to a remotely mounted flow meter enclosure, use only factory supplied cables. When connecting more than one meter, do not intermix the sensor probes and electronics. The electronics, sensor probes and interconnecting cables supplied by Sierra Instruments are calibrated as a complete precision mass flow circuit.

To make wiring connections from a sensor probe junction box to a remotely mounted enclosure, see Figure 2-13. Note: Figure 2-13 is shown without the pressure transducer.



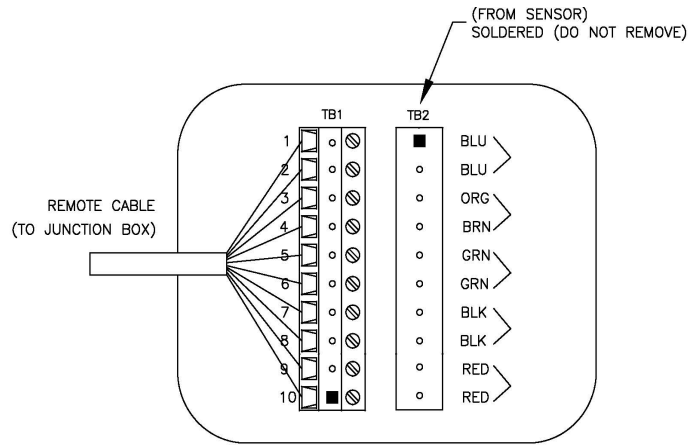

FIGURE 2-13  
REMOTE JUNCTION BOX

TERMINAL BLOCK TB1 #	REMOTE PROBE CABLE WIRE COLOR
1	BLUE
2	BLUE/BLACK
3	ORANGE
4	ORANGE/BLACK
5	GREEN
6	GREEN/BLACK
7	BLACK
8	BLACK/WHITE
9	RED
10	RED/BLACK

Figure 2-13: Remote E4 VT Junction Box

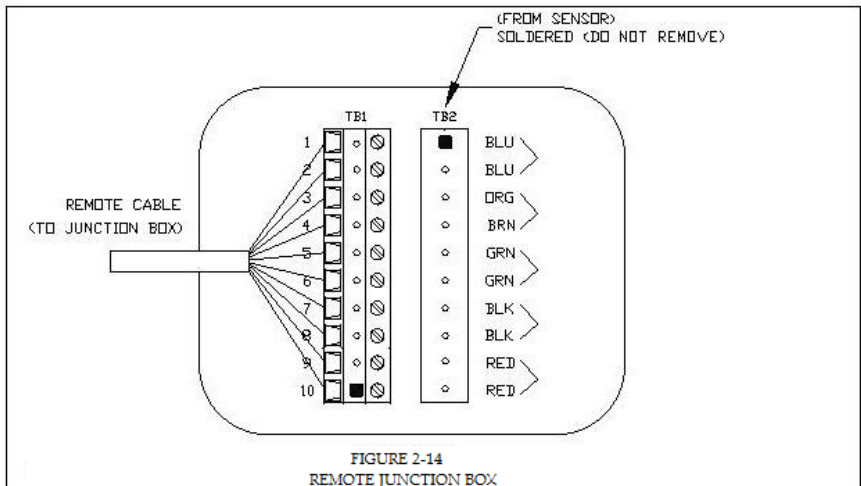

FIGURE 2-14  
REMOTE JUNCTION BOX

TERMINAL BLOCK TB1#	REMOTE PROBE CABLE WIRE COLOR
1	Blue/Black
2	Blue/White
3	Orange/Black
4	Black/Dark Red
5	Green/Black
6	Green/White
7	Black/White
8	White/Black
9	Red/Black
10	Red/White

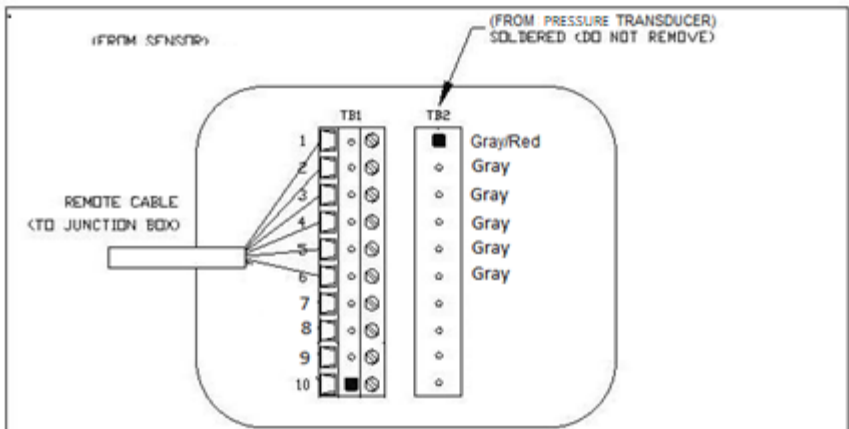

FIGURE 2-15  
REMOTE JUNCTION BOX

TERMINAL BLOCK TB1#	REMOTE PROBE CABLE WIRE COLOR
1	Red
2	Orange
3	Green
4	White
5	Blue
6	Black
7	
8	
9	
10	

Figure 2-14 and 2-15 Remote Junction Box Pressure Transducer Option

# Chapter 3: Operation & Programming

## General Navigation

In general terms, the menu system consists of a main menu, the set-up menu, a sub-menu to program each item in the set-up menu, and a series of data entry or pull-down screens to enter set-up data for each parameter.

Menus may be adjusted using the six buttons on the front of the unit: up ▲, down ▼, left ◀, right ▶, enter ↵ and escape/cancel ⊗, or by using the Smart Interface Program (SIP) software provided free with the instrument.

Pressing the left ◀ button will move the menu selection to the left, or the data entry field to the left if updating a menu value.

Pressing the right ▶ button will move the menu selection to the right, or the data entry field to the right if updating a menu value.

Pressing the up ▲ button will move the menu selection up, or increment the data entry field if you're updating a menu value.

For example, if you're updating a value, and that value is currently set to "0", pressing the up ▲ key will increase the value to the next logical value, in our example it would be "1", then "2", "3" and so on to "9" then back to "0"

Pressing the down ▼ button will move the menu selection down, or decrement the data entry field if you're updating a menu value.

For example, if you're updating a value, and that value is currently set to "9", pressing the down ▼ key will decrease the value to the next logical value, in our example it would be "8", then "7", "6" and so on to "0" then back to "9"

Pressing the enter ↵ key accepts the current value.

Pressing the escape/cancel ⊗ key returns to the last previous menu, and if you're currently editing a value, will cancel any changes you've made.

**Note: The screen data "flashes" to show that you are actively editing. Pressing the enter key permanently writes the data to the meters memory.**

## Start-up Routine

Then the meter is first powered up, it will cycle through set-up data. See an example below of the type of screens you will see.

1. Product Name, Bootloader Version, Display and Main PCA Firmware Versions.

Sierra  
Bootloader v2.x

QuadraTherm v2  
Display v2.x.xx

iSeries Main  
v2x.xx

iSeries Display  
v2x.xx

2. Date and Time

Date: XX/XX/XX  
Time: XX:XX:XX

**NOTE:** All of these values are also displayed on the provided SIP (Smart Interface Program) software.

## Level 1: Main Menu

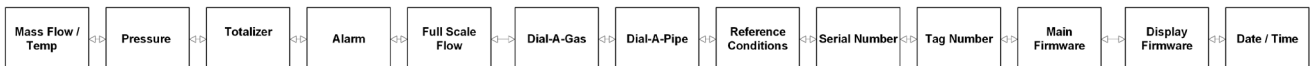

Table 3-1: Main Menu Level 1

Once set-up data is displayed, the meter will display the variables. The instrument will Auto Scroll through each variable. You can turn OFF the Auto Scroll feature by hitting the ▼ down arrow.

Auto Scroll  
Off

Turn Auto Scroll back ON again by hitting the ▲ up arrow. Auto Scroll will default back to on if power is cycled.

Auto Scroll  
On

The following variable screens will Auto Scroll. The data shown below is for example only:

1. Flow and Temperature

0.11 SCFM  
97.66 F

2. Pressure

Pressure  
0.00/psia

3. Totalizer

Total Units SCF  
0.00

4. Alarm

Active Alarm  
Type On/Off

5. Date and Time

Date  
Time

You can now cycle through more main menu screens. By entering >, you will see the additional screens. You can also go back using < at any time or exit to the main screen by pressing (X).

6. Alarm

Active Alarm  
Flow – L (On)

7. Full Scale Flow

Full Scale Flow  
100.00 SCFM

8. qTherm Dial-A-Gas (Gas Type)

Dial-A-Gas  
Carbon Dioxide

9. qTherm Dial-A-Pipe

Dial-A-Pipe  
ID

10. Reference Conditions

Ref: Standard  
14.695949 / 70.0

11. Serial

Serial  
1234XXXX

12. Tag

Tag  
1234XXXX

13. Main PCA Firmware Version

Main  
Firmware

14. Display PCA Firmware Version

Display  
Firmware

15. Date and Time

Date  
Time

And finally complete the cycle back to the flow and temperature screen.

## Level 2: Sub-Menu (Password Protected)

At this point, you can access various other menus . To enter the next level press the enter key. You will be requested to enter a password. Default is 0000 and can be reset in a later screen or using SIP:

Password 0000
------------------

Use the up ▲ and down ▼ buttons to cycle through numbers and left ◀ and right ▶ buttons to move to the next digit. Once the correct password has been entered, hit enter ↵ and you will enter the Level 2 Sub-Menu shown in Table 3-2.

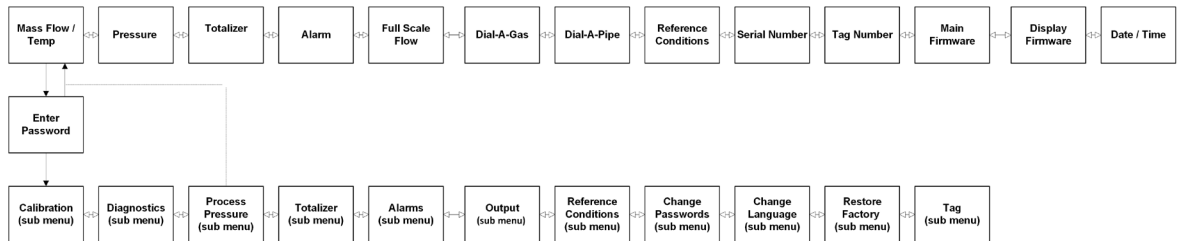

Table 3-2: Level 2 Sub-Menu

## Calibration (Sub-Menu)

Navigate to the Calibration Sub Menu, use Table 3-3 below for guidance if necessary.

The calibration menu allows you to set up the meter to match the application.

Calibration (Sub-Menu)
---------------------------

To start, move down to the next level by pressing the enter key (↵). From this level, you can set up Dial-A-Gas and Dial-A-Pipe, as well as flow and temperature units (pressure is optional and has its own set-up menu to be covered later).

In addition you can adjust the MeterTune (span adjust), full scale flow, low flow cut-off and view the date the meter was last calibrated. Note that you can also use the Quick Keys or the function selector of the Smart Interface Program (SIP) provided free with the meter.

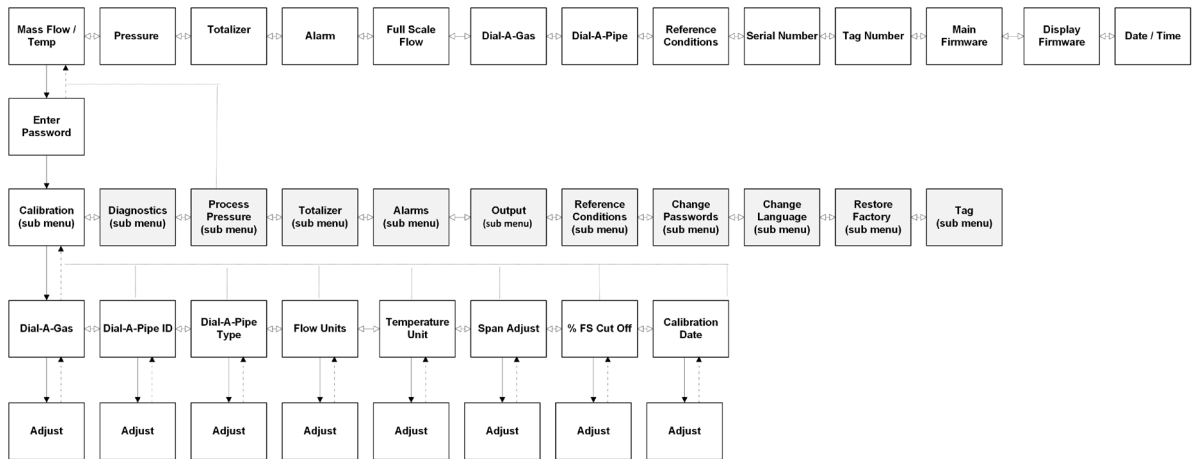
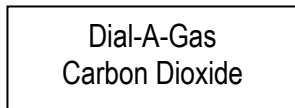

Table 3-3: Calibration Sub-Menu

### Calibration (Sub-Menu): Gas Type –“qTherm Dial-A Gas”

Use this menu to change and select the gas to be measured. This is called our Dial-A-Gas feature and is a powerful and unique feature of the 640i/780i.

The display will show gas type and list the currently selected gas.



Navigate to the “Dial-A-Gas” screen. Use Table 3-3: Calibration Sub-Menu for guidance if necessary.

Once on the “Dial-A-Gas” screen, press enter key once again until the current selected gas begins to flash. It may take a few seconds to begin to flash.

Use the up and down keys to scroll through the available qTherm Dial-A-Gas menu. The meter can be pre-configured with four gases from Sierra’s qTherm Gas Library. There are eighteen gases and gas mixes available from the Sierra qTherm Gas Library. Sierra will continually update the library as more gases and mixtures become available. New or updated gases can be downloaded from the library using the SIP program.

#### Default gases:

Air

Once you have selected the desired gas, press enter key to make the change permanent. The selection will stop flashing.

You can press the exit several times to climb back up to the main menu level or press to proceed to the next Calibration Sub-Menu called Dial-A-Pipe ID. We discuss this next.



## **Calibration (Sub-Menu): Dial-A-Pipe ID, Dial-A-Type**

This instrument can be moved to different pipe sizes and types as needed and perform precision flow measurement. This capability is called Dial-A-Pipe and is a powerful and unique feature of the QuadraTherm 640i immersible thermal mass flow meter.

The internal pipe diameter (ID) and pipe type are very important factors when considering flow profile. The 640i uses internal diameter (ID) and the pipe type to mathematically model the flow profile and enable Dial-A-Pipe.

Adjustment can also be done using the SIP (Smart Interface Program) Software. It is recommended to use the SIP to perform Dial-A-Pipe since the process is more automated.

*The Dial-A-Pipe process requires 2 steps:*

- 1) Setting Pipe Inner Diameter (ID)**
- 2) Setting Pipe Type**

**Step 1(Dial-A-Pipe):** Navigate to the “Dial-A-Pipe ID” screen. Use Table 3-3: Calibration Sub-Menu for guidance if necessary.

The display will show pipe inner diameter in the units selected. In the example below the inside diameter of the pipe is 6.065000 inches.

Dial-A-Pipe ID  
6.065000 / In

Press enter  to cause the first digit (the 6 in 6.065000 in our example) to begin flashing. Use the up and down arrows to select the value 0 to 9. Once done, use the right key to move on to the selected significant digit. Once the I.D. value is selected, use the up and down keys to select the desired units.

**IMPORTANT:** It is vital to use the correct I.D. and units of the pipe where the instrument is located. If the schedule of the pipe is known, the I.D. can be looked up from pipe tables. If the pipe outer diameter and wall thickness is known, the I.D. can be calculated. If you do not have a round pipe, you must enter the equivalent round I.D. There are various methods of calculating this. Here’s an easy calculation to give you the hydraulic diameter ( $H_D$ ):

**Hydraulic Diameter =  $H_D$**

$$H_D = \frac{4A}{P}$$

A = Cross sectional area of duct  
P = Wetted perimeter of duct

I.D. Units:

in: inches

m: meters



mm: millimeters

ft: feet

**Step 2 (Dial-A-Pipe Type):** Pipe roughness does matter. The friction losses of the gas moving through the pipe are a major factor in the instrument's calculation of the flow profile. Navigate to the "Pipe Type" screen. Use Table 3-3: Calibration Sub-Menu for guidance if necessary.

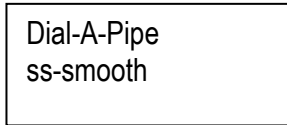
Use this menu screen to complete entering Dial-A-Pipe data. The display will show pipe roughness and the "type" of pipe. See example below.



Press enter  and the type of pipe will begin flashing. Go to the next level down with the  button and select the proper pipe type.

Choices Available:



PVC  
Glass  
ss-UHP  
ss-smooth  
ss-normal  
ss-rough  
cs-smooth  
cs-normal  
cs-rough  
carbon-fiber  
cast-iron  
concrete

where:

ss = stainless steel

cs = carbon steel

UHP = ultra-high purity (5 – 10 Ra finish)





Again, use the  up and  down keys to select. Choice will flash until the enter key  is pressed. Once the selection is made, the instrument Dial-A-Pipe feature is complete.

You can press the exit  several times to climb back up to the main menu level or press  to proceed to the next Calibration Sub-Menu called Flow Units.

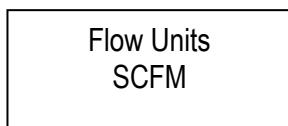
***Calibration (Sub-Menu): Flow Units***

Navigate to the "Flow Units" screen. Use Table 3-3: Calibration Sub-Menu for guidance if necessary. Use this menu to enter the units for mass velocity or flow. The display will show the previously selected flow units. For example:



Press enter  and the units will begin flashing. Go to the next level with the  button and select the proper pipe type. Again, use the  up and  down keys to select. The current choice will flash until the enter key  is pressed.

Available Choices:

- **SCFS, SCFM, SCFH, SCFD, SCFY:** Standard Cubic Feet per Second, Minute, Day, Hour or Year. Standard conditions are set in the Reference Conditions menu.
- **MSCFS, MSCFM, MSCFH, MSCFD, MSCFY:** Thousand Standard Cubic Feet per Second, Minute, Day, Hour or Year. Standard conditions are set in the Reference Conditions menu.
- **MMSCFS, MMSCFM, MMSCFH, MMSCFD, MMSCFY:** Million Standard Cubic Feet per Second, Minute, Day, Hour or Year. Standard conditions are set in the Reference Conditions menu.
- **NCFS, NCFM, NCFH, NCFD, NCFY:** Normal Cubic Feet per Second, Minute, Day, Hour or Year. Normal conditions are set in the Reference Conditions menu.
- **SM3/sec; min; hr; day; yr:** Standard cubic meters per unit time. Standard conditions are set in the Reference Conditions menu.
- **NM3/ sec; min; hr; day; yr:** Normal cubic meters per unit time. Normal conditions are set in the Reference Conditions menu.
- **SLPS,SLPM, SLPH, SLPD, SLPY:** standard Liters per unit time. Standard conditions are set in the Reference Conditions menu.
- **NLPS,NLPM, NLPH, NLPD, NLPY:** normal Liters per unit time. Normal conditions are set in the Reference Conditions menu.
- **Lbs/sec; min; hr; day; year:** Pounds per unit time.
- **Kg/sec; min; hour; day; year:** Kilograms per unit time.
- **SFPS, SFPM, SFPH, SFPD, SFPY:** Standard Feet per Second, Minute, Day, Hour or Year. Note this is a point VELOCITY.
- **SMPS, SMPM, SMPH, SMPD, SMPY:** Standard Meters per Second, Minute, Day, Hour or Year. Note this is a point VELOCITY.
- **KSCFS, KSCFM, KSCFH, KSCFD, KSCFY:** Thousand Standard Cubic Feet per Second, Minute, Day, Hour or Year. Standard conditions are set in the Reference Conditions menu.

You can press the exit ⊗ several times to climb back up to the main menu level or press ► to proceed to the next Calibration Sub-Menu called Temperature Units.

### ***Calibration (Sub-Menu): Temperature Units***

Use this menu to enter the units for temperature. Use Table 3-3: Calibration Sub-Menu for guidance if necessary. The display will show the currently selected temperature unit.

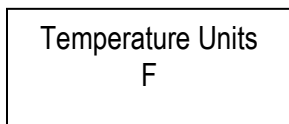

Press enter ↵ and the units will begin flashing. Use the up ▲ and down ▼ keys to select. The units will flash until the enter key is pressed again.

Choices Available:

- F (Fahrenheit)
- C (Celsius)
- K (Kelvin)

- R (Rankine)

Once the temperature units have been selected press enter (↵) to save. You can press the exit ⊗ several times to climb back up to the main menu level or press ▶ to proceed to the next Calibration Sub-Menu called Span Value.

### **Calibration (Sub-Menu): Span Adjust**

The Span Adjust multiplies the meter output by a fixed value, from 0.5000000 to 2.0000000. Displayed MeterTune is for the currently selected gas. This is useful if the meter displays a known offset from another device or expectation (calculated flow rate for example), and you want to make the meters “match”.

For instance, assume your process needs a less accurate rotameter that reads 100 SCFM, and the more accurate 640i or 780i that reads 95 SCFM to align. Enter a span factor of  $100/95 = 1.052632$ . The meter will then multiply by this factor so that the meter output equals the rotameter output of 100 SCFM. Default is of course 1.000000.

Span Adjust 1.000000
-------------------------

Press enter (↵) and the units will begin flashing. As in previous examples, use the ▲▼▶◀ buttons to enter the desired value, and the enter key (↵) to save the value.

You can press the exit ⊗ several times to climb back up to the main menu level or press ▶ to proceed to the next Calibration Sub-Menu called Low Flow Cut Off.

### **Calibration (Sub-Menu): % FS Cutoff**

The Low Flow % Full Scale Cut Off value forces both the digital display and the analog output values to zero/4 mA at a percentage of full scale from 0 to 10% of the full scale value. This is useful because pipes can show flow when all valves are shut.

The QuadraTherm 640i and 780i are extremely sensitive flow instruments that can pick up natural convection flows, where thermal gradients cause gas movement inside the piping system. Phenomenon’s like natural convection will lead to totalization errors.

Displayed value is for the currently selected gas.

% FS Cutoff 0.000000
-------------------------

Enter the desired low flow cut off as a percentage of the full scale flow. The full scale flow is calibrated at the factory and is found in the main menu. You can press the exit ⊗ several times to climb back up to the main menu . For example, if the full scale flow as found in the main menu is:

Full Scale Flow 100.00 SCFM
--------------------------------

And the meter consistently shows a flow of 2 to 3 SCFM even with all valves closed (and you are sure there are no leaks), an example is to set the low flow cut off just above to:

Low Flow Cut-Off 5.000000
------------------------------

This is +/- 5% of the full scale of 100 SCFM. The analog output and the digital display be 4mA/0.000000 for any flow below 5.000000 SCFM. The default value for low flow cut off is 1.000000.

Once the low flow cut off has been entered, use the enter key (↵) to save the value. You can press the exit ⊗ several times to climb back up to the main menu level or press ► to proceed to the next Calibration Sub-Menu called Calibration Date.

### Calibration (Sub-Menu): Calibration Date

The Calibration Date is a read-only field that shows when the meter was last factory-calibrated in MM/DD/YYYY format.

Calibration Date 08/13/2012
--------------------------------

Sierra recommends recalibration as required by your metrology policy or when the meter validation routine found in the Smart Interface Program software detects a problem. See Meter Validation in SIP ValidCal™ Diagnostics screen).

You can press the exit ⊗ several times to climb back up to the main menu level or press ► to proceed to the next Calibration Sub-Menu called Full Scale.

### Diagnostics (Sub-Menu)

In the Diagnostics Sub-Menu, you can read the maximum and minimum: flow, pressure & temperature. Many other advanced parameters can be viewed, edited, and even simulated from this menu, see table below.



**NOTE:** Caution should be used when stimulating or editing any parameters as this will effect the performance of the meter.

Navigate to the Diagnostics (Sub Menu), use Table 3-4 below for guidance if necessary.

Use the left ◀ and right ▶ buttons to view these values. Use the UDLREE buttons to edit or simulate the various parameters. Press the exit ⊗ button several times to climb back up to the main menu level or press ► to proceed to the next Sub-Menu called Process Pressure (Sub Menu).

**NOTE:** Extensive diagnostics are available via the Smart Interface Program (SIP) software.

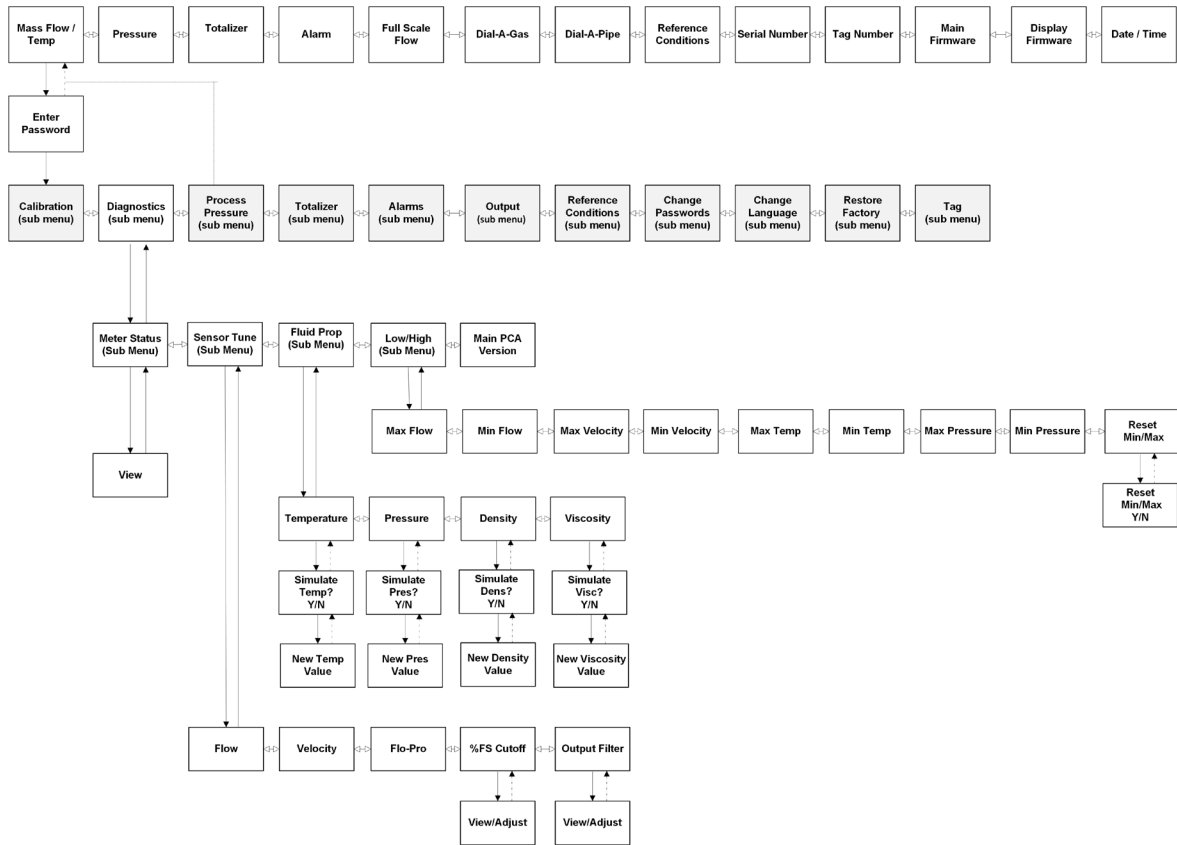

Table 3-4: Diagnostics (Sub Menu)

**Output Filter (Sub-Menu):**

Use this menu to view or change your current Output Filter value. Navigate to the Output Filter (Sub-Menu), use Table 3-4 above for guidance if necessary.

This value is a smoothing or averaging function of the indicated flow rate. This value can be from 1 to 200. Increasing this value will smooth-out the indicated flow rate more and slow down the time response slightly.

Decreasing this value will make the indicated flow noisier, but will also speed up the response time slightly.

Press enter (↵) and the units will begin flashing. As in previous examples, use the ▲▼▶◀ buttons to enter the desired value, and the enter key (↵) to save the value.

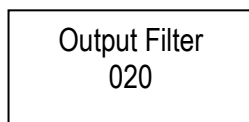

Hit the exit key to return to the main top menu.

**Process Pressure (Sub-Menu)** Navigate to the Process Pressure Sub Menu, use Table 3-5 below for guidance if necessary.

The QuadraTherm 640i and 780i is a **multivariable** thermal mass flow meter. It always measures mass velocity (from which the mass flow rate is derived) and temperature (VT) and has the optional ability to measure process pressure along with VT, this is called (VTP). The Process Pressure Sub-Menu allows you to input the desired pressure units.

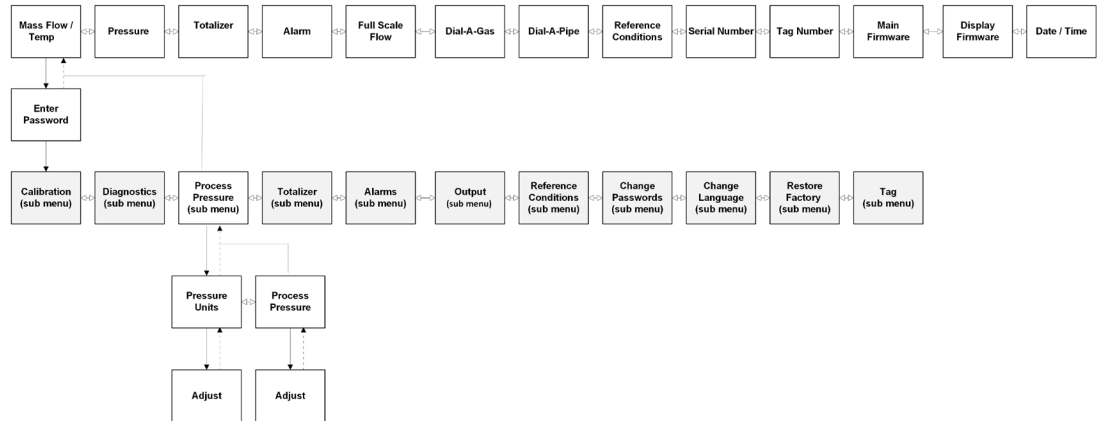

Table 3-5: Process Pressure Sub-Menu

**Process Pressure (Sub-Menu): Pressure Units**

Use this menu to enter the units for pressure.



**NOTE:** Please note that this sub-menu is only for a **VT meter** and is not active on a VTP meter as the pressure sensor value is used instead.

Use the enter key (↵) to drill down to Pressure Units selection. Press enter (↵) and the units will begin flashing. Use the ▲▼ buttons to enter the desired information, and the enter key (↵) to save the value.

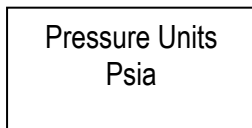

Available units are:

- Psia
- Psig
- Bar A
- Bar G
- KPa A
- KPa G
- Kg/CM2 A
- Kg/CM2 G
- In H2O A
- In H2O G

- MM H2O A
- MM H2O G

Once the pressure units have been selected press the enter key (↵) to save. You can press the exit (⊗) several times to climb back up to the main menu level or press (▶) to proceed to the next Sub-Menu called Process Pressure Temperature Units.

### Process Pressure Sub-Menu: Process Pressure

Use this menu to enter the process pressure.



**NOTE:** Please note that this sub-menu is only for a **VT meter** and is not active on a VTP meter as the pressure sensor value is used instead.

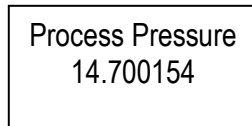

This process pressure is used by the instruments qTherm mathematical model to improve gas properties calculations. Gas properties have a very slight dependence on pressure, so if process pressure changes appreciably over time this value should be updated to reflect process conditions (about 0.01% per psi).

The units of the pressure in this menu are the same as what was set in the previous menu. In the example above, the units are 14.700154 Psia since this is what was set in the pressure units sub-menu.

This concludes our review of the Process Pressure Sub-Menu. Press the exit (⊗) climb back up to the main menu.

### Totalizer (Sub-Menu)

The Totalizer Sub Menu controls all aspects of the totalizer function. Totalizers are used to monitor accumulated flow, often for billing and cost allocation purposes. The totalizer sub-menu is used to turn the totalizer ON or OFF, to reset, and to tell the meter when to send out a totalizer pulse and what that pulse should look like.

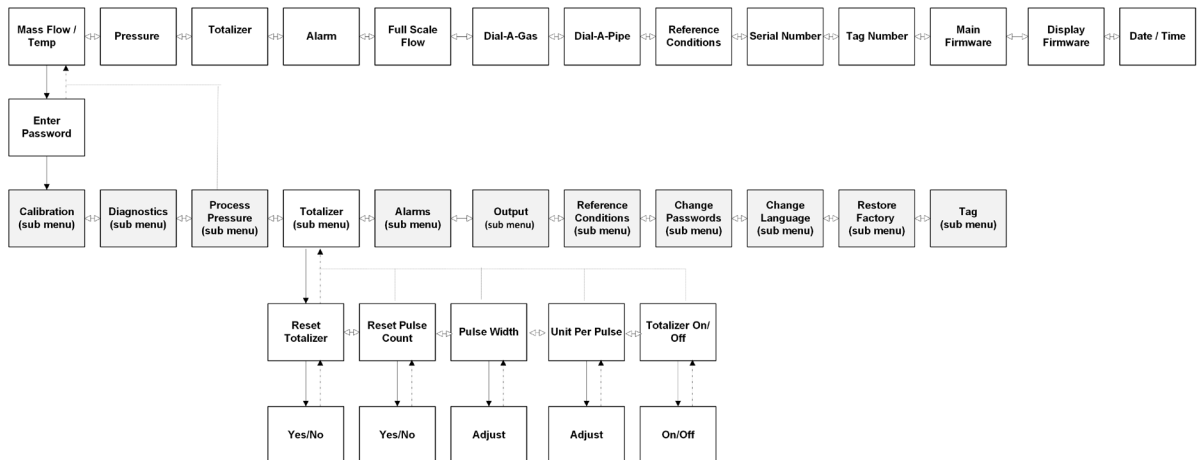



### **Totalizer (Sub-Menu): Reset Totalizer**

Navigate to the Reset Totalizer screen, use Table 3-6 above for guidance if necessary.



NOTE: Resetting the Totalizer also resets the pulse count.

Use this menu to reset the totalizer to zero. Press enter (↵) and you will see a flashing “YES”. Pressing enter (↵) again to reset the totalizer to zero and bring you back to the Totalizer (Sub-Menu).

Reset Totalizer Yes
------------------------

In addition, from the screen above you can press the down ▼ button to a flashing “NO”. Pressing enter ↵ will return back to the Totalizer (Sub-Menu).

### **Totalizer Sub-Menu: Reset Pulse Count**

Navigate to the Reset Pulse Count screen, use Table 3-6 above for guidance if necessary. Please note that resetting the Pulse Count also resets the Totalizer.

Use this menu to reset the pulse counter. The pulse count is the count of pulses that went to the pulse relay since the last reset. This count will match your external counter if they were both reset at the same time and can be used to verify an external counter. Pulse count X units per pulse= totalizer count within +/- 1 units per pulse value.

The screen example below, there were 349 pulses since the last reset.

Reset Pulse Cnt. 349
-------------------------

To reset this to zero, press enter (↵) and a “YES” will appear and flash.

Reset Pulse Cnt. YES
-------------------------

Press enter (↵) again and the pulse counter will be reset. In addition, from the screen above you can press the down ▼ button to a flashing “NO”. Pressing enter (↵) will return back to the Reset Pulse Count screen. If you answered YES, the count will read zero “0”.

Reset Pulse Cnt. 0
-----------------------

### **Totalizer (Sub-Menu): Pulse Width**

Use this menu to set the width of the pulse in milliseconds. Navigate to the Pulse Width screen, use Table 3-5 above for guidance if necessary.

The pulse output is an isolated relay contact, so one pulse of for example with a default value of 50ms closes the normally open relay for 50ms. Some counters work straight off of the relay contacts closing and some pull up the relay so when it closes it is a negative 50ms pulse. The 640i and 780i can use just the contacts or an approximately 10K pull-up resistor.

#### Choices Available:

- Adjustable from 1-1000 (ms)

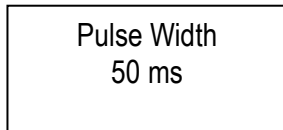

In the screen example above, the pulse width will close the isolated normally open contacts for 50ms, the frequency of the pulse varies with flow rate and units per pulse value (see below) but cannot exceed 1Hz maximum.

Press enter (↵) and the value will begin flashing. Press the up button ▲ down button ▼ or left button ◀ right button ▶ to choose the desired pulse width. Next, press the enter key (↵) to save. You can press the exit ⊗ several times to climb back up to the main menu level or press ▶ to proceed to the next Sub-Menu called Units Per Pulse.

### **Totalizer (Sub-Menu): Units Per Pulse**

Use this menu to select the units per pulse. Navigate to the Units Per Pulse screen, use Table 3-5 above for guidance if necessary. **Note the maximum frequency at which the totalizer can count is 1 pulse per second, or 1 Hz.** This puts a limit on the units per pulse and makes resolution dependent on flow rate.

For example: Assume the maximum flow rate is 100 SCFM and you want the totalizer to pulse every 5 SCF. Since the flow is 100 SCFM, it will take 5/100 minutes, or 3 seconds to totalize 5 SCF. That is acceptable since the totalizer takes longer than 1 second to accumulate SCF.

Assume that now you want more resolution, so you would like the totalizer to pulse every 1 SCF. Since the flow is 100 SCFM, it will take 1/100 minutes, or 0.6 seconds to totalize 1 SCF. Since the instrument's totalizer is 1 Hz. It can't pulse any faster than a maximum rate of once per second (1 Hz).

In this example, the best units per pulse would be 1.7 SCF; that is just over the 1 HZ maximum sampling rate.

$$\frac{1 \text{ SCF}}{.6 \text{ seconds}} \times \frac{\text{second}}{\text{pulse}} = 1.7 \frac{\text{SCF}}{\text{pulse}}$$

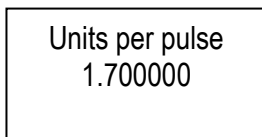

Press enter (↵) and the units will begin flashing. As in previous examples, use the ▲▼▶◀ buttons to enter the desired value, and the enter key (↵) to save the value.

Press ▶ to proceed to the Totalizer On/Off screen or press the exit ⊗ several times to climb back up to the main menu level.

**NOTE:** The units of the totalizer are the same as entered in the units menu (minus the time since this is an accumulation and not a rate).

### ***Totalizer (Sub-Menu): Totalizer On/Off***

Use this menu to turn the totalizer On or Off. Use Table 3-5 for guidance if necessary. Press enter (↵) and the variable will begin flashing. As in previous examples, use the ▲▼ buttons to select On or Off, and press enter (↵) to save the value.

Totalizer ON
-----------------



**NOTE:** The Totalizer can only be used when mass units are being used. For example, Lbs/Hr or Kg/Hr.

Totalizer set up is now complete. This concludes our review of the Totalizer (Sub-Menu). Press exit ⊗ to climb back up to the main menu.

### ***Alarm (Sub-Menu)***

The alarm sub menu controls all aspects of the 640i and 780i Alarm feature. The instrument can be set to alarm on *one* of the following variables: Flow, Pressure, Temperature or Totalizer. The instrument alarm can be set on *one* of the following conditions: Low, High or Window. The Window alarm becomes active when the parameter reads higher OR lower than the set point (when it is outside of its “operating window”).



Table 3-7: Alarm Sub Menu

### **Alarm (Sub-Menu): Active Alarm**

Navigate to the Active Alarm screen, use Table 3-7 above for guidance if necessary. Press enter  $\leftarrow$  and the variable will begin flashing. In the screen example below, the active alarm is “Flow”.

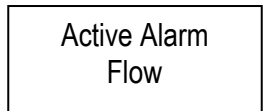

Use the  $\blacktriangle$ / $\blacktriangledown$  buttons to select On or Off, and press enter ( $\leftarrow$ ) to save the value.

#### Alarm Choices Available:

- Flow
- Pressure
- Temperature
- Totalizer
- Off
- Forced On (use only to test the alarm relay)

**NOTE:** Only *one* alarm can be active at any one time. The alarm relay is a normally open isolated contact. The alarm is tripped when the relay closes.

You can press the exit  $\otimes$  several times to climb back up to the main menu level or press  $\blacktriangleright$  to proceed to the next Sub-Menu called Alarm Mode.

### **Alarm (Sub-Menu): Alarm Mode**

Navigate to the Alarm Mode screen, use Table 3-6 above for guidance if necessary. Press enter  $\leftarrow$  and the variable will begin flashing. In the screen example below, the active alarm condition is “Low”.

Active Mode  
Low

Use the ▲▼ buttons to select On or Off, and press enter (↵) to save the value.

Available Choices:

- High
- Low
- Window

**Alarms (Sub-Menu)**

The Alarms (Sub Menu) allows you to set the Low and High alarm values for Flow, Pressure, Temperature, and Totalizer.

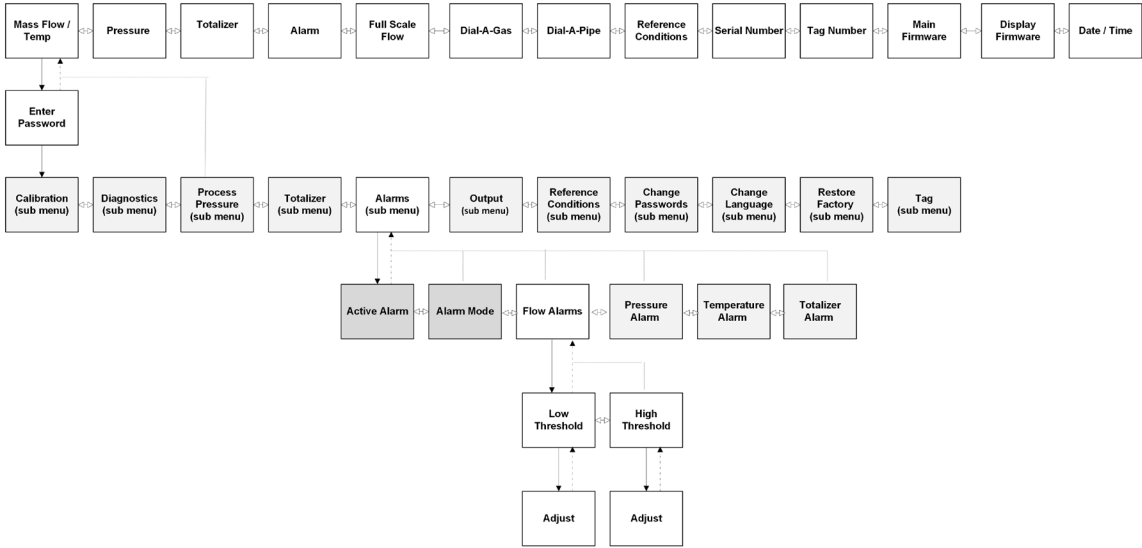

Table 3-7.1: Flow Alarms (Sub Menu)

We will set a low flow alarm to demonstrate the Alarms function. Navigate to the Flow Alarms (Sub Menu) screen, use Table 3-7.1 above for guidance if necessary. Assume that you already set the Active Alarm to “Flow” and the alarm condition is set to go off on a “Low” flow. The Flow Alarms (Sub Menu) allows you to set the actual alarm setpoint .

Press enter (↵) and the units will begin flashing. As in previous examples, use the ▲▼◀▶ buttons to enter the desired numeric value, and the enter key (↵) to save the value.

In the example screen below, 10 SCFM has been entered. The units were already set in the units menu.

Low (SCFM)  
000010.000000

If you wanted to now set a High alarm, press the right key ▶ and the High alarm setup screen

will appear.

Note: If you wanted to set the active alarm on pressure, temperature or totalizer (instead of flow), press the right key **▶** to reach the appropriate sub-menu and use the **▲▼▶◀** buttons to enter the desired numeric value, and the enter key (**↵**) to save the value

This concludes our review of the Alarms Sub-Menu. Press the exit **⊗** climb back up to the main menu.

### **Output Adjust (Sub-Menu): Flow, Pressure and Temperature**

	<p>It should be noted that the 4/20mA settings, DAC settings and 4/20 values, will be already setup at the factory for the 4mA and 20mA. It is advisable that you do not change these values unless you fully understand why you are changing them.</p> <p>In the event that you need to adjust your 4/20mA values, or feel that you may need a refresher on how the of the 4/20mA protocol works, please refer to the “Understanding 4/20mA communications” tutorial on the Sierra website to get a better understanding on the settings before you make any changes.</p>
-----------------------------------------------------------------------------------	----------------------------------------------------------------------------------------------------------------------------------------------------------------------------------------------------------------------------------------------------------------------------------------------------------------------------------------------------------------------------------------------------------------------------------------------------------------------------------------------------------------------------------------------------------------------------

The QuadraTherm® 640i and 780i comes standard with linear 4 to 20 mA analog outputs for flow and temperature. If the pressure option is selected, a third linear 4 to 20 mA analog output is provided for pressure.



Table 3-8: Output (Sub Menu)

Use the output adjust menu to view, test, or adjust the 4 and 20 mA raw digital DAC counts value for these parameters as well as to view or adjust the pressure and temperature values that correspond to 4 and 20mA. Zero flow always corresponds to 4mA and full scale flow always corresponds to 20mA.

All values in the output menu have been calibrated and set at the factory. You only need to enter these screens if you wish to view, adjust, or test any of the values.

### **Setting Up: 4-20 mA Outputs**

We will set Flow 4-20 mA to demonstrate this function. The same routines apply for setting up Pressure 4-20 mA and Temperature 4-20 mA.

#### **Fullscale Flow : View, Adjust**

Navigate to the Fullscale Flow screen in the Output (Sub Menu), use Table 3-8 above for guidance if necessary. This is the Flow value that corresponds to 20mA output. Use the UDRL buttons to enter the desired numeric value and the enter key (E) to save the value. Note that accuracy is still based on the original factory calibration full scale value.

Fullscale (SCFM) 100.00
----------------------------

#### **Flow 4 mA : View, Test, Adjust**

Navigate to the Flow 4 mA screen in the Output (Sub Menu), use Table 3-8 above for guidance if necessary. From this menu, press enter to get to the flow 4 mA setup screen.

Flow 4 mA 724
------------------

This numeric value is the DAC value that produces 4 mA on the analog flow output. In the example screen DAC is 724. Press enter (↵) and the units will begin flashing. Increasing this value will raise the 4 mA output and decreasing this value will lower the 4 mA output. Use the ▲▼▶◀ buttons to enter the desired numeric value, and the enter key (↵) to save the value.

You can then use the down ▼ button to force/test flow 4 mA output and hit the up ▲ button to stop the force/test. It will flash testing until you stop the test. You can repeat this process, if desired, until you achieve the desired result.

Flow 4 mA 724 - Testing
----------------------------

#### **Flow 20 mA : View, Test, Adjust**

Navigate to the Flow 20 mA screen in the Output (Sub Menu), use Table 3-7 above for guidance if necessary. From the Fullscale Flow screen, pressing the right ▶ button will send you to the view, test, or adjust screen for 20 mA value.

This value is the DAC value that produces 20 mA on the analog flow output. In the example screen DAC is 3612. Press enter (↵) and the units will begin flashing. Increasing this value will raise the 20 mA output and decreasing this value will lower the 20 mA output. Use the ▲▼▶◀ buttons to enter the desired numeric value, and the enter key ↵ to save the value.

Flow 20 mA 3612
--------------------

You can then use the down ▼ button to force/test flow 20 mA output and hit the up ▲ button to stop the force/test. It will flash testing until you stop the test. You can repeat this process, if desired, until you achieve the desired result.

Flow 20 mA  
3612 - Testing

**NOTE:** The engineering units are as set in the Calibration (Sub Menu). Go to that section for more detailed information.

In the example above, assume full scale flow is 100 SCFM. As a result, a 20 mA output equals 100 SCFM and 4 mA output equals 0.00000 SCFM. Zero flow always corresponds to 4mA. The output is linear between these two points, in this example, if we had a flow of 50 SCFM, the output would be 12 mA.

Once you have completed viewing, testing, and adjusting the flow, pressure, and temperature 4-20 mA DAC values press the right key ► to reach the appropriate sub-menu and use the ▲▼▶◀ buttons to enter the desired numeric value, and the enter key (↵) to save the value

### ***Setting Up 4 to 20 mA for Temperature and Pressure***

Follow the same process as setting up the Flow 4-20mA outlined above.

Pres 4mA  
0.00

The pressure units above are the current pressure units you ordered or that you have changed in the process pressure sub-menu. In the example above if your pressure units are psia then 0.00 psia would correspond to the pressure 4mA output. Press enter key (↵) and use the left right up and down keys to modify this value if desired and then press the enter key (↵) to accept. Press the right key to continue to the Pres 20mA value that corresponds to the 20mA output.

Pres 20mA  
30.00

In the example above, if your pressure units are psia then 30.00 psia would correspond to the pressure 20mA output. Press enter key (↵) and use the left right up and down keys to modify this value if desired and then press the enter key (↵) to accept. If you change this value be sure not to enter a Pressure High value greater than the full scale of the pressure option you ordered or you would be over the range of the transducer. If you change these pressure low/high values the pressure accuracy is still based on the original +/-1% of full scale of the Pressure transducer option ordered. Press the right key to continue to the temperature low value that corresponds to the 4mA output.

Temp 4mA  
32.00

The temperature units above are the current temperature units you ordered or that you have changed in the calibration sub-menu. In the example above, if your temperature units are °F



then 32.00 °F would correspond to the temperature 4mA output. Press enter key (↵) and use the left right up and down keys to modify this value if desired and then press the enter key (↵) to accept. Press the right key to continue to the Temp 20mA value that corresponds to the 20mA output.

Temp 20mA  
212.00

In the example above, if your temperature units are °F then 212.00 °F would correspond to the temperature 20mA output. Press enter key (↵) and use the left right up and down keys to modify this value if desired and then press the enter key (↵) to accept. If you change these temperature low/high values the temperature accuracy is still based on the original +/-1°C specification.

In the above examples, from 32.00° F to 212.00° F or from 0 to 30 psia would correspond to the 4 and 20mA analog outputs for temperature and pressure. These values are dependent upon your process. Finally, exit back to the set-up menu and right to reference conditions.

### Reference Conditions (Sub-Menu): Standard and Normal

Use this menu to establish the reference conditions as specified in the units menu. Navigate to the Reference Conditions (Sub Menu), use Table 3-9 below for guidance if necessary.

Ref. Conditions  
(Sub Menu)

Press enter (↵) once and then use the ◀▶ buttons to select “Standard” or “Normal” .

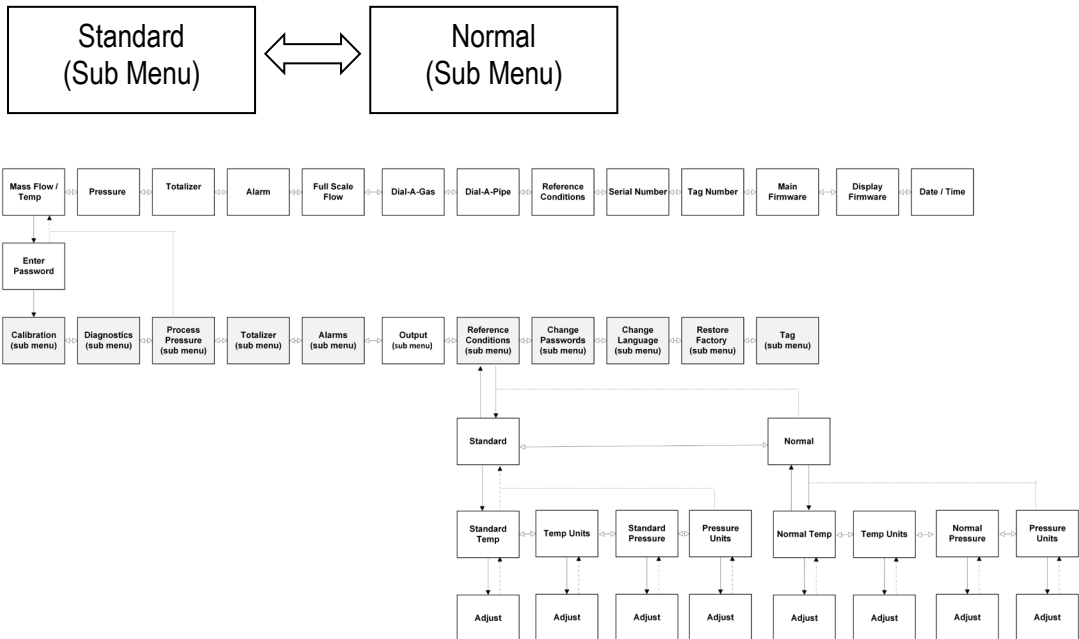

Table 3-9: Reference Conditions (Sub Menu)

For example, SCFM (Standard Cubic Feet per Minute) is commonly used in the United States.

The S = Standard in SCFM and is referenced to 70°F (21.1°C) and 14.696 Psia (or 1 atmosphere).

In Europe, Nm<sup>3</sup>/hr (Normal Cubic Meters per Hour) is commonly used. The N = Normal and is generally referenced to 0°C and 101.32 KPa A(or 1 atmosphere).

Once a “Standard” or “Normal” selection has been made press enter (↵) again to go to the adjust screen.

From here you can adjust instrument reference conditions and units. To adjust, press (↵) again and the units will begin flashing. As in previous examples, use the ▲▼▶◀ buttons to enter the desired value, and press enter (↵) to save the value.

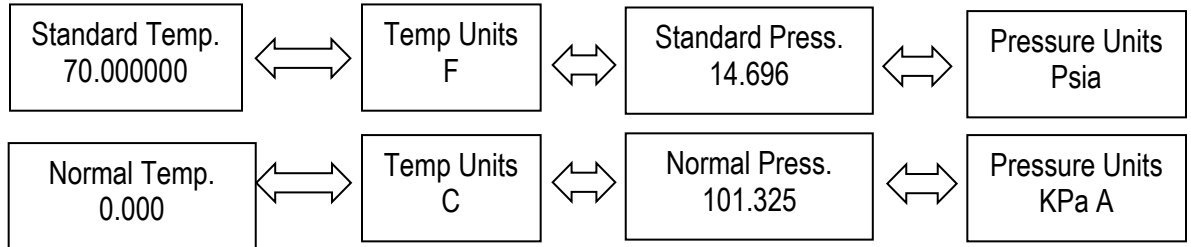

Once you are done press the enter key (↵) to save. You can press the exit ⊗ several times to climb back up to the main menu level or press ▶ to proceed to the next Sub-Menu called Change Password (sub menu).

### ***Change Password (Sub-Menu)***

Use this menu to set or change a password. Navigate to the Change Password (Sub Menu), use Table 3-4 above for guidance if necessary.

A password is required to access the set-up sub menu's. Press enter (↵) and the four digit password units will begin flashing. As in previous examples, use the ▲▼▶◀ buttons to enter the desired value, and press enter (↵) to save the value.

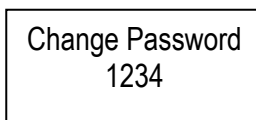

The default password is 0000. If you have lost your password and can't gain needed access to the setup screens, you can contact our service department for a password that would allow you to access the setup screens and setup a new password.

You can press the exit ⊗ several times to climb back up to the main menu level or press ▶ to proceed to the next Sub-Menu called Change Language.

### ***Change Language (Sub-Menu)***

Navigate to the Change Language (Sub Menu), use Table 3-9 above for guidance if necessary.

Use this menu to change the displayed language. Use SIP program to download latest languages to your device.

You can press the exit ⊗ several times to climb back up to the main menu level or press ► to proceed to the next Sub-Menu called Restore Factory.

Change Language US-English
-------------------------------

***Restore Factory (Sub-Menu):***

Use this menu to restore all parameters to the original factory conditions. This will undo any changes you have made.

Navigate to the Restore Factory (Sub-Menu), use Table 3-9 above for guidance if necessary.

Press enter (↵) and the YES will begin flashing. As in previous examples, use the ▲▼ buttons to enter YES or NO, and press the enter key (↵) to save.

Restore Factory YES
------------------------

You can press the exit ⊗ several times to climb back up to the main menu level or press ► to proceed to the next Sub-Menu called Output Filter.

# Chapter 4: Troubleshooting & Repair

## Troubleshooting the Flow Meter

Begin hardware troubleshooting by verifying the following facilities issues are correct. These areas impact system operation and must be corrected prior to performing any flow meter inspections.



### Caution

Before attempting any flow meter repair, verify that the line is not pressurized.



### Caution

Always remove main power before disassembling any part of the mass flow meter.

1. Verify the incoming power to the flow meter is present and of the correct voltage and polarity.
2. Check the flow meter wiring for correct connections as described in Chapter 2.
3. Verify the flow meter is installed with the correct number of upstream and downstream pipe diameters as shown on page 2-2.
4. Verify the flow direction indicator is correctly aligned pointing downstream of flow.
5. Make sure there are no leaks in the line being measured.

After verifying the factors above, follow the troubleshooting procedures outlined on the next page. If you need to return the flow meter to the factory, see page 54 for return shipping instructions.

<b><i>Problem</i></b>	<b><i>Possible Cause</i></b>	<b><i>Solution</i></b>
<b>Velocity measurement is erratic or fluctuating</b>	Very erratic or non-uniform flow	Follow installation requirements shown in Chapter 2
	Flow meter installed with less than required minimum pipe diameters upstream and downstream of the sensor	Follow installation requirements shown in Chapter 2
	Insertion sensor probe not mounted securely	Sensor probe must be mounted securely without vibration
	Sensor component broken	Return to factory for replacement
	Malfunction in system electronics	Return to factory for evaluation
	Ground loop	Check wiring, see Chapter 2
	Moisture present in gas flow	Install a water trap or filter upstream of the flow sensor
<b>Velocity measurement seems too high or low</b>	Sensor assembly not aligned correctly to flow	Correct alignment with the flow indicator pointing downstream in the direction of flow
	Sensor probe not inserted to the proper depth	Verify sensing point is located on the centerline of the pipe
<b>No response to flow from sensor assembly</b>	No power	Turn on power to the flow meter
	Low flow cutoff too high	Correct low flow cutoff programming using the Smart Interface software or display menu.
	Flow rate below meter's minimum flow rating	Contact factory for instructions
	Flow has exceeded the maximum range of the flow meter	Set the user full scale to equal the factory full scale  Reduce flow below the maximum range shown on the meter's nameplate or contact the factory for re-calibration advice
	Flow profile distortions	Try to find another location for the meter
	Extremely turbulent flow	Do not place the meter near a ventilator, static mixer or valve
	Sensor failure	Return to factory for evaluation
	Printed circuit assembly defective	Return to factory for evaluation

## **Returning Equipment to Factory**

### **Factory Calibration—All Models**

Sierra Instruments maintains a fully-equipped calibration laboratory. All measuring and test equipment used in the calibration of Sierra transducers are traceable to NIST Standards.

Sierra is ISO-9001 registered and conforms to the requirements of ANSI/NCSL-Z540 and ISO/IEC Guide 25.

### **Instructions for Returning Your Instrument for Service**

The following information will help you return your instrument to Sierra Instruments' Factory Service Center and will ensure that your order is processed promptly. Prices may vary depending on the flow range, type of gas and operating pressure of your unit. To request detailed pricing, contact your local Sierra Instruments distributor or contact one of our offices directly.

### **Please follow these easy steps to return your instrument for factory service:**

1. To obtain a Return Materials Authorization (RMA) number from the Sierra Instruments to <http://www.sierrainstruments.com/rma/new.php> to create a Sierra Account.
2. Once you have created an account, click on the *Submit New RMA* tab and fill in the RMA form and follow the instructions. You will receive an email confirmation once you have submitted your RMA.
3. Print a copy of the RMA (that now includes RMA #) and send a copy of the RMA form along with your meter back to the factory.

If you require service beyond calibration, but do not know which service(s) will be required, describe the symptoms as accurately as possible on the RMA form.

Pack your instrument carefully. Use the original packaging and foam or bubble wrap (packing peanuts NOT recommended) and include a copy of the RMA form (complete with Sierra supplied RMA number) with the unit(s).

### **Watch Video for Tips On How to Properly Package Your 640i for Shipping**

See our [short 3-minute video](#) which offers a few simple, but important, packing tips for the QuadraTherm 640i to avoid any damage during transport.

Ship the unit(s) to the following address:

**Sierra Instruments, Inc.  
Attention: Factory Service Center  
20 Ryan Ranch Road, Suite 109  
Monterey, CA 93940 USA  
RE: RMA# (your number)**

# Appendix A: Product Specifications

4

## PERFORMANCE SPECIFICATIONS

### Gases Measured

All inert gases and all non-condensing clean gases  
Flammable gases: methane, propane, hydrogen, digester gas, natural gas  
Corrosive gases compatible with 316 SS, 316L SS, and Pt/Ir (velocity sensor)  
qTherm Gas Library: most common gases and mixtures; air is standard; qTherm Dial-A-Gas option for choice of three additional gases

### Mass Velocity Range for Air

0 to 60,000 sfpm (0 to 305 smps) at 21.1°C (70°F), 1 atm

### Multivariable Outputs

Mass flow rate (standard)  
Temperature (standard)  
Pressure (optional)  
Totalized flow: totalized value is stored in non-volatile memory

### Mass Flow Accuracy

780i Inline version accuracy (highest accuracy):\*  
+/- 0.5% of reading above 50% of the full scale flow  
+/- 0.5% of reading plus 0.5% of full scale below 50% of full scale flow

### 640i Insertion version accuracy:\*

+/- 0.75% of reading above 50% of the full scale flow  
+/- 0.75% of reading plus 0.5% of full scale below 50% of full scale flow

See Table 1: qTherm Dial-A-Gas Selection Chart on next page for accuracy.

Gas pressure accuracy +/- 1.0% full scale  
Totalize each gas independently with the flow totalizer

\* Accuracy statements verified by an independent NIST and NVLAP accredited metrology laboratory.

### Gas Temperature Accuracy

+/- 1°C (1.8°F)

### Gas Pressure Ranges

30 psia (2.1 bara), 100 psia (6.9 bara), 300 psia (20.7 bara),  
500 psia (34.5 bara), VTP only.

### Repeatability

Mass flow rate: +/- 0.15% of full scale  
Gas temperature: +/- 0.5°C (0.9°F)  
Gas pressure: +/- 0.5% of full scale

### Response Time

Three seconds to achieve 63% (one time constant) of final value

### Mass Flow Rate Turndown

100:1 turndown

## ANALOG AND DIGITAL OUTPUTS

### Output Signals

4-20 mA flow, 4-20 mA temperature, 4-20 mA pressure (optional)  
Alarm output (contact SPST/opto relays)  
User definable pulse output for totalized flow

### Optional Communications Modules

Modbus RTU, HART

## SOFTWARE

### Smart Interface Program (SIP) Software

Use Dial-A-Gas and Dial-A-Pipe for easy field setup  
Use Meter Tune to optimize performance  
Use ValidCal to validate all meter functions  
Use flow totalizer to totalize the flow  
Use qMix gas mixing feature to create custom gas and gas mixtures

## POWER REQUIREMENTS

### Input Power

100 to 240 VAC (0.4 Amps RMS at 230 VAC)  
24 VDC +/- 10%, 1.04 Amps

## OPERATING SPECIFICATIONS

### 780i Inline Version Gas Pressure Requirements

NPT: 500 psia (34.5 bara) maximum -1 NAA Only, 300 psig (20.7 barg) maximum for -2 or -3 agency approved units

Flange process connections defined by the ASME B 16.5a – 1998 spec. group rating of 316L stainless steel ANSI class 150

316L stainless steel 150 class flanges:

230 psig at -20°F to 100°F; 195 psig at 200°F;  
175 psig at 300°F; 160 psig at 400°F; and 145 psig at 500°F

Equivalent DN PN16 flanges are available (see page 10 for sizes)

### 640i Insertion Version Gas Pressure Maximums (or limits)

Compression fittings: 500 psia (34.5 bara)  
1-inch 150 class flange (-40°F to 250°F) 185 psia (12.8 bara)  
Low pressure hot tap: 150 psia (10.3 bara)  
High pressure hot tap: 230 psia (15.9 bara)  
Minimum pipe size 2 inches (50 mm)

### Gas Temperature Requirements (all versions)

-40°F (-40°C) to 392°F (200°C)  
High temperature (HT) option to 750°F (400°C) available in 640S model only

### Ambient Temperature (NAA and cFMus versions)

-40°F (-40°C) to 140°F (60°C)  
ATEX/IECEx Versions -4°F (-20°C) to 140°F (60°C)

## PHYSICAL SPECIFICATIONS

### User Interface

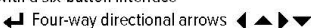
Local keypad with a six-button interface  
Exit  Enter   
RS-232 or USB with PC software for communication and programming

### Digital Display

UltraBright, backlit, LCD digital display, 2 x 16, 2 x 32 scrolling

### 780i Inline Version Process Connections

See page 9 and 10 for NPT, ANSI class 150 flange and PN16 DN sizes.

### 640i Insertion Version Process Connections

See page 6 through 8 for insertion sizes.  
ANSI 1-inch - ANSI class 150 flange (optional)  
Low pressure hot tap rated to 150 psia (10.3 bara)  
High pressure hot tap and retractor 230 psia (15.9 bara)

### Wetted Materials

316 SS, 316L SS, and Pt/Ir (velocity sensor)  
Viton® VTP Pressure Option

### Leak Integrity

5 x 10<sup>-9</sup> sccs of helium maximum

### Approval Agencies

cFMus—Explosion proof for Class I, Div I, Groups B,C,D  
CE—European Conformity  
ATEX/IECEx

### Enclosure

NEMA 4X (IP66), hazardous-area explosion proof, flow pointer, meter information tag.

TABLE 1: qTherm Dial-A-Gas Selection Chart				
Gas	780i Accuracy		640i Accuracy	
	Actual Gas <sup>(1)</sup>	qTherm Dial-A-Gas <sup>(2)</sup>	Actual Gas <sup>(1)</sup>	qTherm Dial-A-Gas <sup>(2)</sup>
Air <sup>(3)</sup>	±0.5%	N/A	±0.75%	N/A
Ammonia	N/A	±3.0%	N/A	±3.0%
Argon	±0.5%	±3.0%	±0.75%	±3.0%
Carbon Dioxide	±0.5%	±3.0%	±0.75%	±3.0%
Chlorine	N/A	±3.0%	N/A	±3.0%
Digester Gas (60% CH <sub>4</sub> , 40% CO <sub>2</sub> )	±0.5%	±3.0%	±0.75%	±3.0%
Helium	±0.5%	±3.0%	±0.75%	±3.0%
Hydrogen	±0.5%	±5.0%	±0.75%	±5.0%
Methane	±0.5%	±3.0%	±0.75%	±3.0%
Nitrogen	±0.5%	±3.0%	±0.75%	±3.0%
Oxygen	N/A	+/- 0.75% Reading + 0.5% Full Scale	N/A	+/- 0.75% Reading + 0.5% Full Scale
Propane	±0.5%	±3.0%	±0.75%	±3.0%
Other <sup>(4)</sup> —Consult Factory	Special Calibration Request (SCR)	Special Calibration Request (SCR)	Special Calibration Request (SCR)	Special Calibration Request (SCR)

Notes: (1) % of reading at >50% of full scale flow; add 0.5% of full scale below 50% of full scale flow  
(2) % of full scale unless otherwise noted  
(3) Air is standard on the instrument and cannot be removed  
(4) The qTherm Gas Library is a proprietary gas property index that is continually updated and improved

TABLE 2: 640i/780i Straight Run Requirements				
Piping Condition	Upstream 640i Insertion	Upstream 780i Inline with Flow Conditioning <sup>(1)</sup>	640i Downstream <sup>(2)</sup>	780i Downstream <sup>(2)</sup>
Single 90° Elbow or T-Piece	15D	1D	1D	0D
Two Elbows (in the same plane)	20D	3D	3D	0D
Two Elbows (in different plane)	40D	3D	3D	0D
Reduction (4:1)	15D	3D	3D	0D
Expansion (4:1)	30D	3D	3D	0D
After Control Valve	40D	5D	5D	0D

Notes: (1) Number of diameters (D) of straight pipe required between upstream disturbance and the flow meter  
(2) Number of diameters (D) of straight pipe required downstream of the flow meter

### 780i INLINE PRESSURE DROP

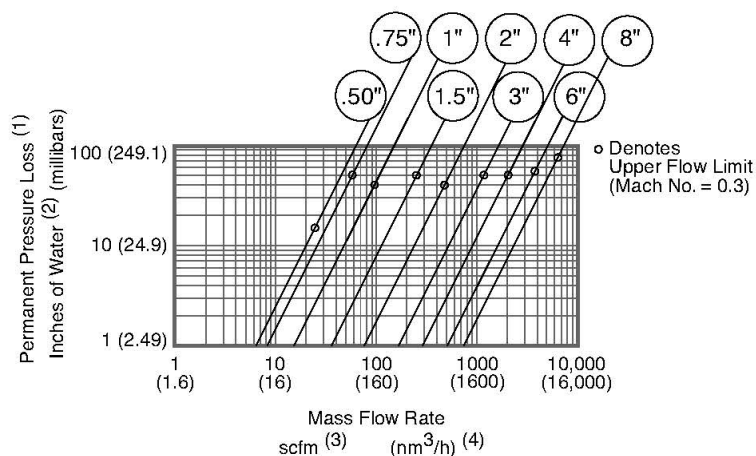

Notes: (1) For air and nitrogen at 20°C temperature and 1 atmosphere pressure  
(2) 1 inch of water at 60°F = 0.0361 psi

(3) At base conditions of 211°C temperature and 1 atmosphere pressure  
(4) At base conditions of 0°C temperature and 1 atmosphere pressure



P2-DD—Side View

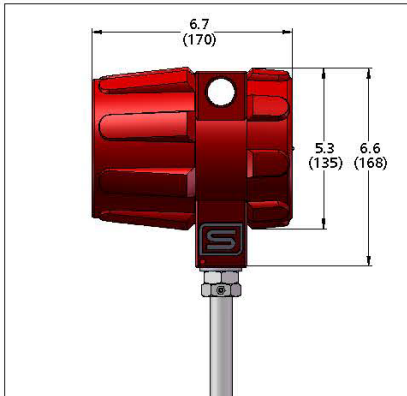

P3-DD—Side View

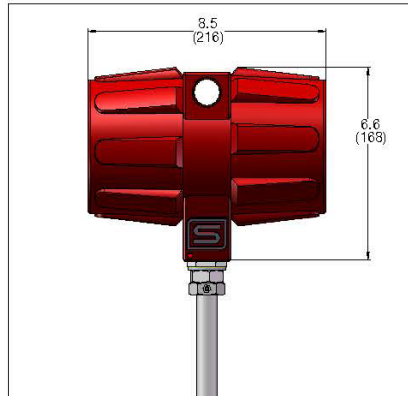

All Versions—Front View

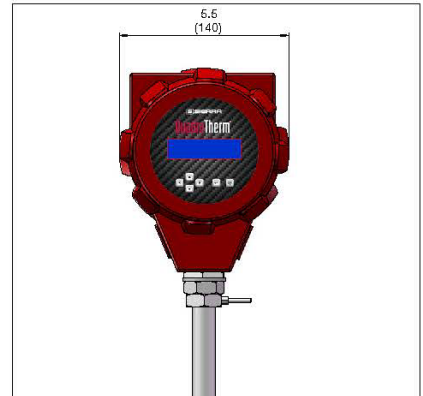

P2-DD Compression Fitting—Side View

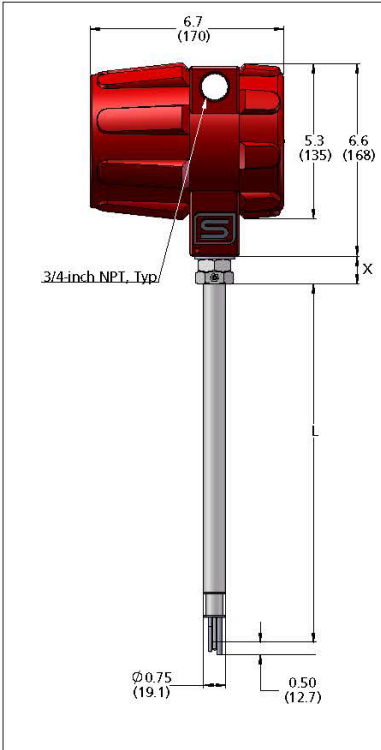

P2-DD Flange Fitting—Side View

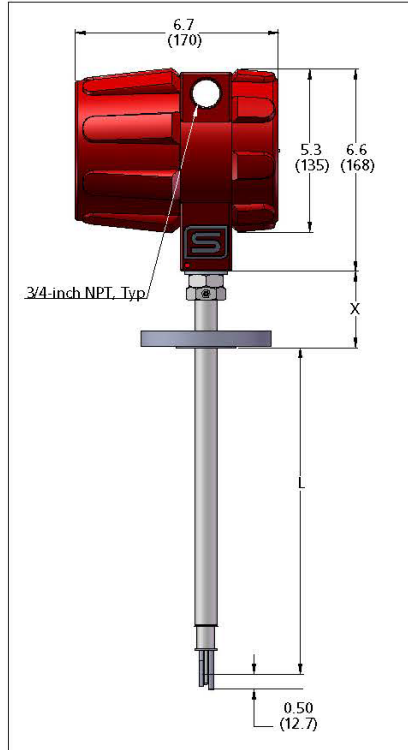

cFMus, ATEX, IECEx Approved Probes (>13")

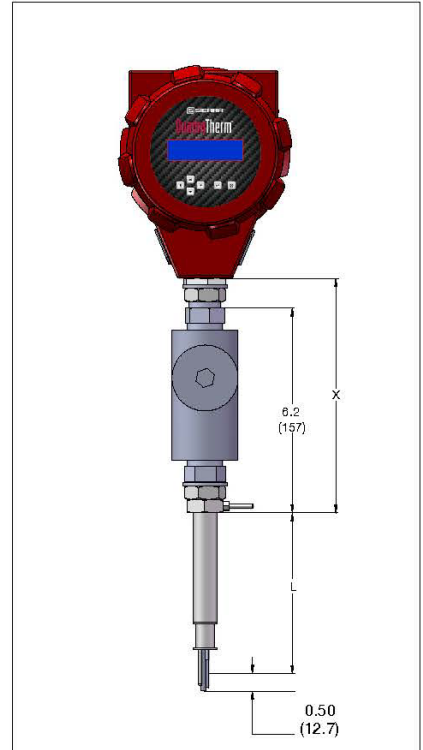

Note: All dimensions in inches with (mm) in brackets; certified drawings available upon request. All drawings have ± .25 inch (6.4 mm) tolerance.

Length Chart 640i Compressions Fittings		
Code	L	X
L06	6.0 (152)	1.25 (31.75)
L09	9.0 (229)	1.25 (31.75)
L13	13.0 (330)	1.25 (31.75)
L18	18.0 (457)	1.25 (31.75)
L24	24 (610)	1.25 (31.75)
L36	36 (914)	1.25 (31.75)
L48	48 (1219)	1.25 (31.75)

Length Chart 640i Flange Mounting		
Code	L	X
L06	6.0 (152)	2.69 (68.33)
L09	9.0 (229)	2.69 (68.33)
L13	13.0 (330)	2.69 (68.33)
L18	18.0 (457)	2.69 (68.33)
L24	24 (610)	2.69 (68.33)
L36	36 (914)	2.69 (68.33)
L48	48 (1219)	2.69 (68.33)

Length Chart 640i FM Version		
Code	L	X
L06	6.0 (152)	10.25 (260.35)
L09	9.0 (229)	10.25 (260.35)
L13	13.0 (330)	10.25 (260.35)
L18	18.0 (457)	10.25 (260.35)
L24	24 (610)	10.25 (260.35)
L36	36 (914)	10.25 (260.35)
L48	48 (1219)	10.25 (260.35)

Remote Electronics VT, VTP—Side View

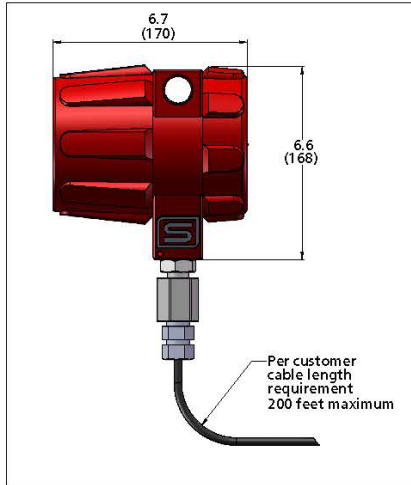

Remote Probe VT—Front View

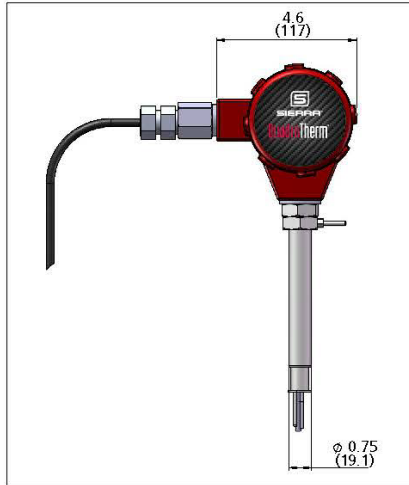

Remote Probe VT—Side View

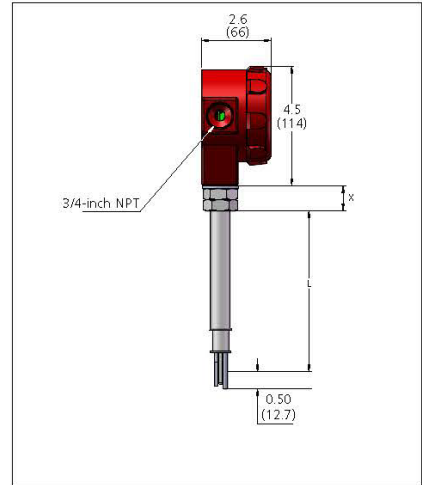

Remote Probe VTP—Front View



Remote Probe VTP—Side View

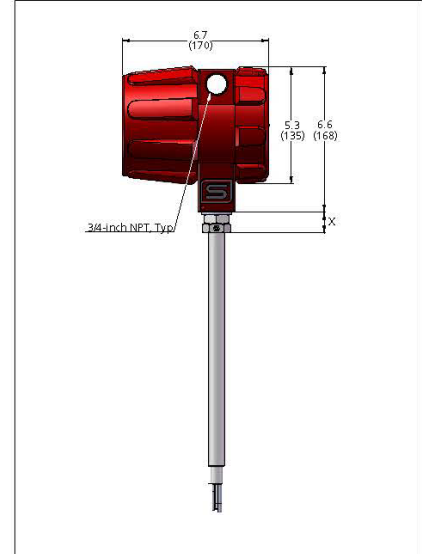

P3-DD Remote Bracket—Side View

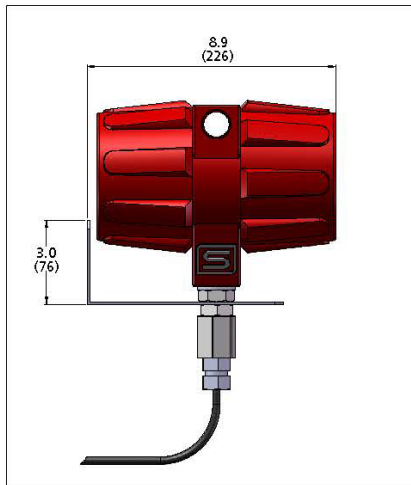

P2-DD Remote Bracket—Side View

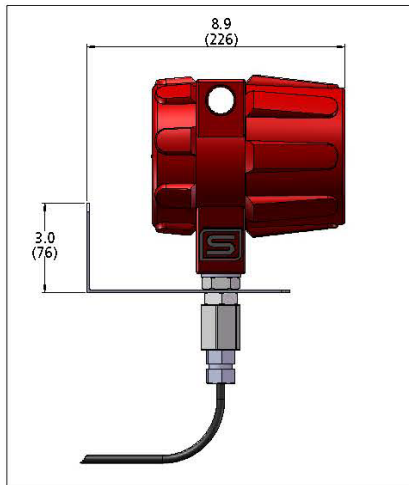

Remote Bracket—Front View

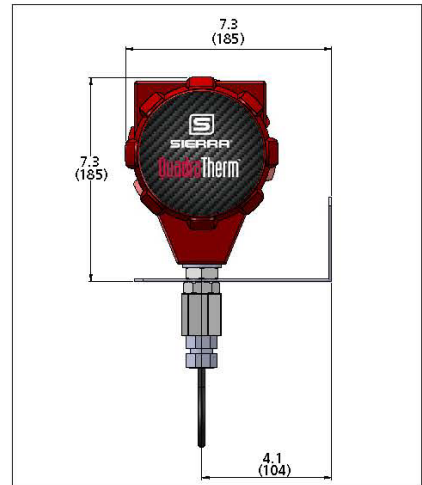

8 Mounting Holes for Remote Bracket

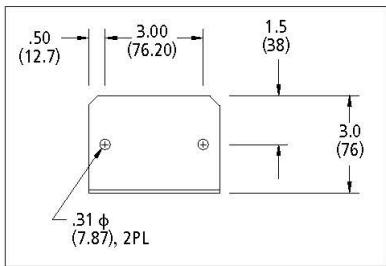

Length Chart 640i Remote Mount Junction Box		
Code	L	X
L06	6.0 (152)	1.25 (37.75)
L09	9.0 (229)	1.25 (37.75)
L13	13.0 (330)	1.25 (37.75)
L18	18.0 (457)	1.25 (37.75)
L24	24 (610)	1.25 (37.75)
L36	36 (914)	1.25 (37.75)
L48	48 (1219)	1.25 (37.75)

640i INSERTION LOW PRESSURE HOT TAP to 150 psig (10.3 barg)

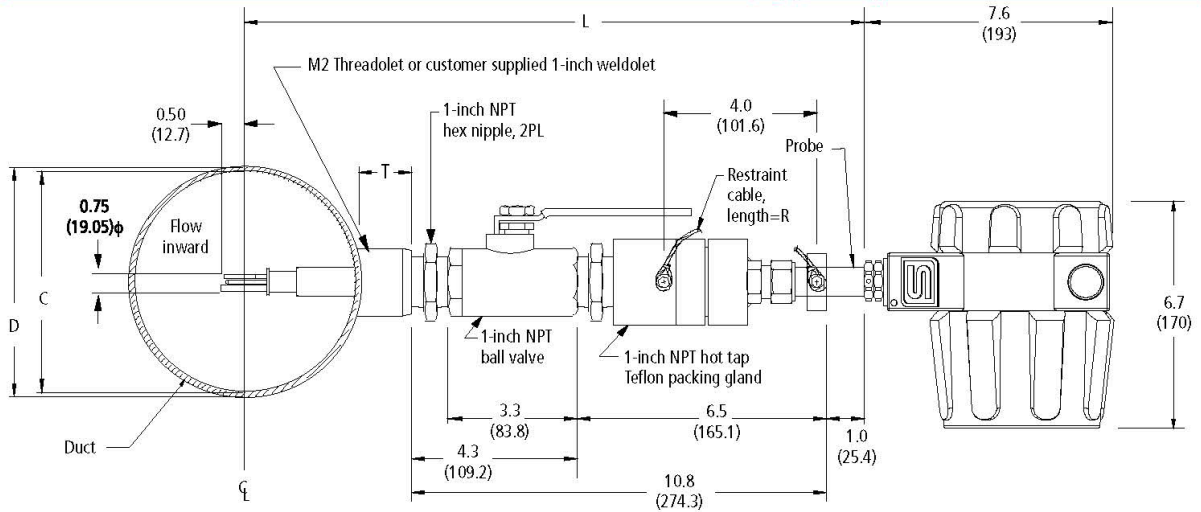

**Variables**  
 L = Nominal Probe Length  
 D = Duct O.D.  
 C = Duct I.D.  
 T = Height of "Threadolet" or Customer Provided Weldolet  
 R = Restraint Cable Length

**Formula**  
 $L > 12.3 + T + D/2$   
 So L must be equal or greater than 12.3-inches plus the height of the "Threadolet" plus half the duct O.D.  
 $R = D/2 + T + 7.3$

640i HIGH PRESSURE HOT TAP is flange dependent up to 400 psig (27.6 barg)

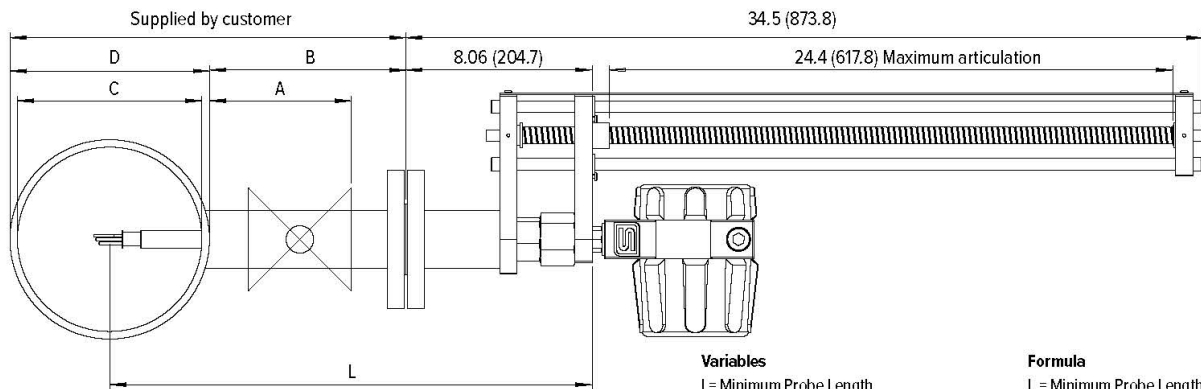

**Variables**  
 L = Minimum Probe Length  
 A = Distance From Duct OD To Valve Outlet  
 B = Distance From Duct OD To Flange Face  
 C = Duct Inner Diameter  
 D = Duct Outer Diameter

**Formula**  
 L = Minimum Probe Length  
 $L = 8 + B + 1/2 D$   
 $D/2 + A \leq 24.4$

Note: All dimensions in inches with (mm) in brackets; certified drawings available upon request

1/2" Through 1 1/2" NPT-Side View

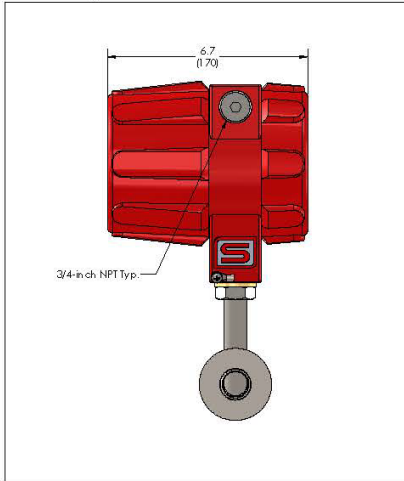

1/2" Through 1 1/2" NPT-Front View

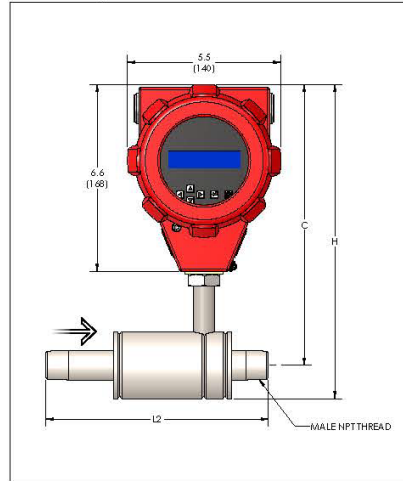

Sizes for NPT			
Size	H	C	L2
1/2-inch	10.5 (267)	9.9 (251)	7.5 (191)
3/4-inch	10.8 (274)	9.9 (251)	7.9 (201)
1-inch	11.2 (284)	9.9 (251)	8.3 (211)
1 1/2-inch	11.5 (292)	9.9 (251)	9.5 (241)

1/2" Through 1 1/2" 150 Class Flange-Side View

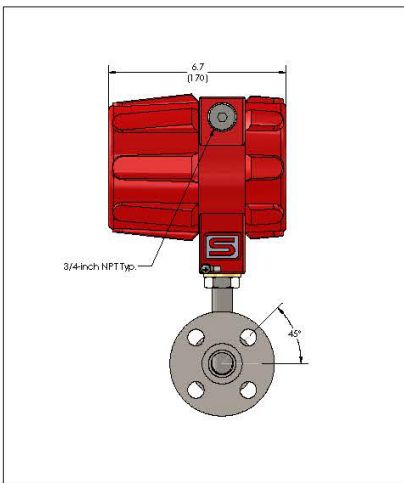

1/2" Through 1 1/2" 150 Class Flange-Front View

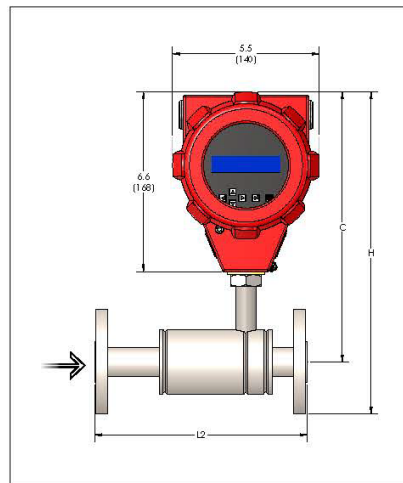

Sizes For ANSI Class 150 Flange			
Size	H	C	L2
1/2-inch	11.6 (295)	9.9 (251)	7.5 (191)
3/4-inch	11.8 (300)	9.9 (251)	7.9 (201)
1-inch	12.0 (304)	9.9 (251)	8.3 (211)
1 1/2-inch	12.2 (310)	9.9 (251)	9.5 (241)

NPT Remote Electronics-Side View

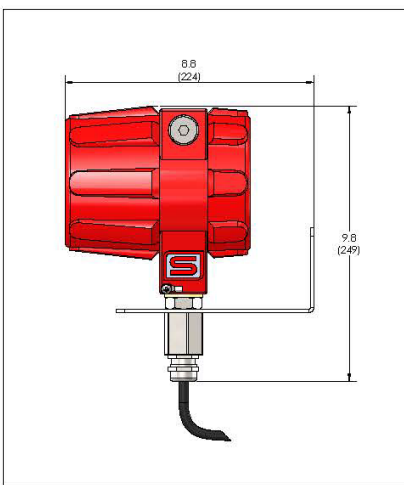

NPT, VT Remote-Front View

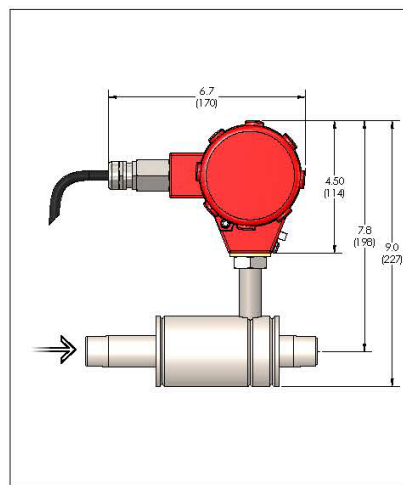

150 Class Flange VT Remote-Front View

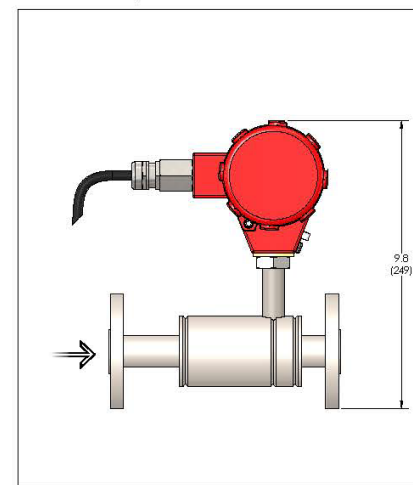

Note: All dimensions in inches with (mm) in brackets; certified drawings available upon request

2" Through 8" 150 Class Flange—Side View

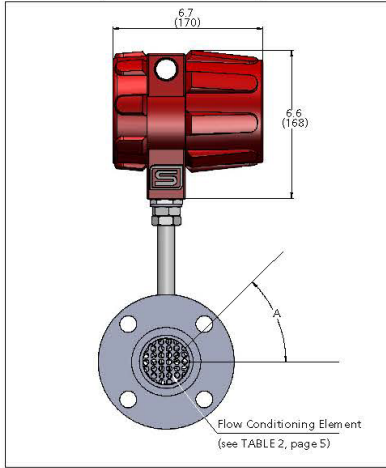

2" Through 8" 150 Class Flange—Front View

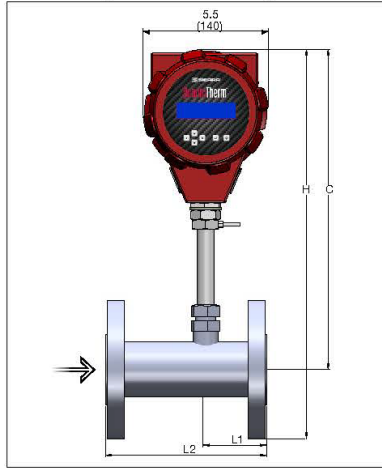

Sizes for ANSI Class 150 Flanges					
Size	H	C	L1	L2	A
2-inch	17.0 (432)	14.0 (356)	2.6 (66)	7.0 (178)	45
3-inch	17.7 (450)	14.0 (356)	2.6 (66)	10.0 (254)	45
4-inch	18.5 (470)	14.0 (356)	3.6 (91)	12.0 (305)	22.5
6-inch	19.5 (495)	14.0 (356)	5.6 (142)	18.0 (457)	22.5
8-inch	20.7 (526)	14.0 (356)	7.6 (193)	24.0 (610)	22.5

2" Through 8" NPT—Side View

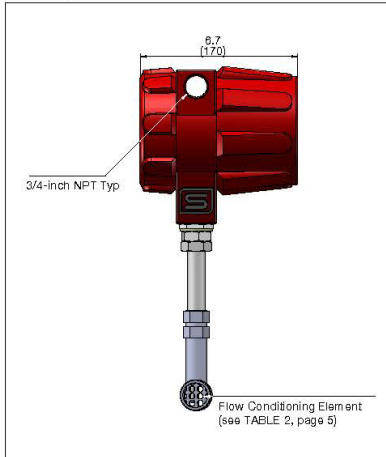

2" Through 8" NPT—Front View

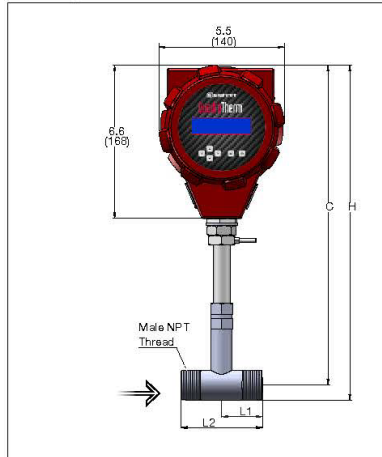

Sizes for 1-inch Through 8-inch NPT				
Size	H	C	L1	L2
2-inch	15.1 (384)	14.0 (356)	3.50 (89)	7.50 (191)
3-inch	15.7 (399)	14.0 (356)	4.00 (102)	10.00 (254)
4-inch	16.2 (411)	14.0 (356)	4.00 (102)	12.00 (305)
6-inch	17.3 (439)	14.0 (356)	6.00 (152)	18.00 (457)
8-inch	18.3 (465)	14.0 (356)	8.00 (203)	24.00 (610)

NPT VT Remote—Front View

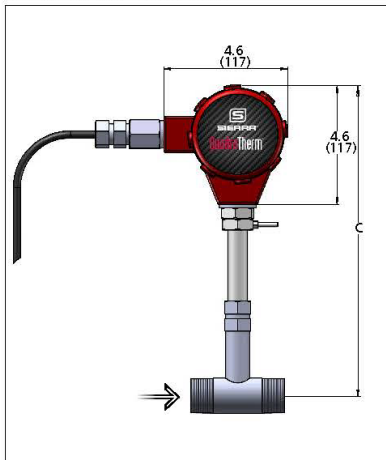

Flange VT Remote—Front View

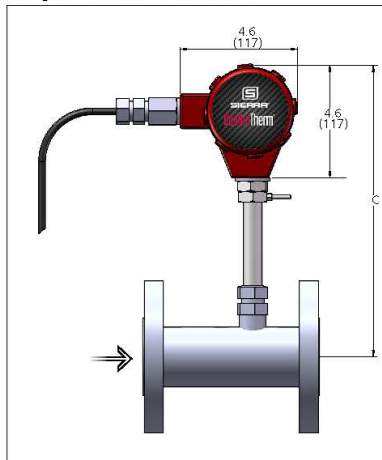

Sizes for PN16 DN Flanges				
Size	H	C	L1	L2
DN50	17.2 (437)	14.0 (356)	3.34 (85)	7.10 (180)
DN80	17.9 (455)	14.0 (356)	4.14 (105)	10.20 (259)
DN100	18.3 (465)	14.0 (356)	4.57 (116)	12.60 (320)
DN150	19.6 (498)	14.0 (356)	6.77 (172)	18.90 (480)
DN200	20.7 (526)	14.0 (356)	8.47 (215)	24.40 (620)

**ORDERING THE 640i INSERTION**

PARENT	FEATURES									DIAL-A-GAS			OPTIONS	
	1	2	3	4	5	6	7	8	9	*10	11	12	13	1
<b>640i</b>	<input type="text"/>	<input type="text"/>	<input type="text"/>	<input type="text"/>	<input type="text"/>	<input type="text"/>	<input type="text"/>	<input type="text"/>	<input type="text"/>	<input type="text" value="0"/>	<input type="text"/>	<input type="text"/>	<input type="text"/>	<input type="text"/>

Instructions: To order a 640i, please fill in each feature number block by selecting the codes from the corresponding features below and following pages.

\*Feature 10 is air (always included)

Feature 1: Multivariable	
<b>640i VT</b>	Thermal Insertion Mass Flow Meter; all 316L stainless steel construction; linear 4-20 mA output signals for Mass Flow Velocity and Temperature, temperatures -40°F to 392°F (-40°C to 200°C); pressure to 500 psig (34.5 barg); standard accuracy (air) +/- 0.75% of reading above 50% of full scale flow and +/- 0.75% of reading plus 0.5% of full scale below 50% of full scale flow; includes qTherm™ Electronics with PC configuration software; 24 VDC +/- 10.0% or 100-240 VAC input power with a 3/4-inch (2 cm) diameter 316 SS insertion sensor probe; configurable alarm and pulse outputs; CE, cFMus, ATEX, IECEx approved
<b>640i VTP</b>	Add a pressure output to the 640i VT version; three 4-20 mA linear outputs for mass flow velocity, temperature, and pressure; includes pressure sensor up to 500 psia (34.5 bara)

Note: Minimum pipe size for insertions is 2 inches (50 mm) diameter.

Feature 2: Approvals	
<b>1</b>	<b>NAA.</b> Non-agency approved.
<b>2</b>	<b>cFMus.</b> Process Temperature Range: -40°C to 200°C (-40°F to 392°F). Class I, Division 1, Groups B,C, and D T3C Ta = -40°C to 60°C (-40°F to 140°F). Type 4x. Maximum probe length is 48 inches (1.22 m). Note: Requires Killark seal for probes >L13, see Note 1
<b>3</b>	<b>ATEX and IECEx.</b> II 2 G Ex db IIC T3 Gb. II 2 D Ex tb IIIC T200°C Db. Ta = -20°C to 60°C (-4°F to 140°F). Process Temperature Range: -40°C to 200°C (-40°F to 392°F). Maximum probe length is 48 inches (1.22 m)

Feature 3: Probe Length	
<b>L06</b>	6-inch (15 cm)
<b>L09</b>	9-inch (23 cm)
<b>L13</b>	13-inch (33 cm)
<b>L18</b>	18-inch (46 cm) If agency approved, see Note 1.
<b>L24</b>	24-inch (61 cm) If agency approved, see Note 1.
<b>L36</b>	36-inch (91 cm) If agency approved, see Note 1.
<b>L48</b>	48-inch (122 cm) If agency approved, see Note 1.
<b>L( ) M5</b>	Probe with 1 inch, class 150 Flange welded to probe. Specify length between flange face and center of pipe in parentheses. Include M5 option Diagram with ADS. Don't select a probe length from Feature 3. Note 1: Killark seal is required for agency approved meters greater than L13 (33 cm). Adds 6.2 in (157 mm) to probe length listed above.

Note 1: Killark seal is required for agency approved meters with >L13. Adds 6.2 in (157 mm) to probe length listed above.

Feature 4: Mounting Options: Standard 3/4" (19.1mm) Diameter Sensor Probe	
<b>M0</b>	Customer to supply own mounting hardware
<b>M1</b>	Compression fitting, 3/4-inch (2 cm) with 1-inch (2.5 cm) male NPT
<b>M2( )</b>	Threadolet 1-inch Female NPT; specify pipe O.D. in parenthesis
<b>M1-M2( )</b>	Compression fitting plus Threadolet. 3/4-inch probe feed through by 1-inch male NPT. Threads into 1-inch Female NPT, which is welded to the pipe. Specify pipe O.D. in parenthesis. <b>We strongly advise to purchase this as a set, since we've seen non compatible NPT threads in the past.</b>
<b>M3</b>	Flat duct bracket, 3/4-inch (2 cm) tube compression fitting
<b>M4( )</b>	Curved duct bracket, 3/4-inch (2 cm) tube compression fitting; specify duct O.D. in parentheses
<b>M8( )</b>	<b>Low pressure hot tap,</b> includes ball valve and packing gland; maximum 150 psig (10.3 barg); specify duct O.D. in parenthesis. <b>Note: M8 option not available for probes less than 18 inches.</b>
<b>L( ) M9</b>	High pressure hot-tap with removable retractor kit assembly includes probe (probe length L in parentheses, MINIMUM length is process connection dependent), removable retractor assembly, packing gland probe seal with a 2-inch ANSI class 150 process connection (other classes available, contact factory) and Conax fitting. Max pressure flange dependent or 500 psig (34.5 barg). Available for probe lengths listed in Feature 3.
<b>M15</b>	Quick removal hot-tap, includes ball valve and compression fitting rated for 40 psig (2.8 barg)

Feature 5: Electronics Enclosure	
<b>E2</b>	Hazardous-area location enclosure NEMA 4X (IP66) mounted directly on probe
<b>E4(10)</b>	10 feet away from the probe with junction box mounted on probe. Note: Customer may cut cable length with no effect on accuracy.
<b>E4(25)</b>	25 feet away from the probe with junction box mounted on probe. Note: Customer may cut cable length with no effect on accuracy.
<b>E4(50)</b>	50 feet away from the probe with junction box mounted on probe.
<b>E4(100)</b>	100 feet away from the probe with junction box mounted on probe. Note: Customer may cut cable length with no effect on accuracy.

Feature 6: Input Power	
<b>P2</b>	24 VDC +/- 10.0%
<b>P3</b>	100-240 VAC

Feature 7: Output	
<b>V4</b>	Two linear 4-20mA outputs for mass flow velocity and temperature
<b>V6 (VTP only)</b>	Three linear 4-20mA outputs for mass flow velocity, temperature and pressure (only available with Feature 1: Multivariable 640i VTP)

Feature 8: Display	
<b>DD</b>	Digital Display: UltraBright LCD indicates mass flow velocity, T, P, alarms and totalized mass flow in engineering units; 6-push button user interface makes selection easy: Dial-A-Gas, Dial-A-Pipe, change units, change language, set alarms and much more...
<b>DD-NRT</b>	Totalizer cannot be reset in the field.

Feature 9: Pressure (VTP only)	
<b>MP1</b>	30 psia (2.1 bara), VTP only
<b>MP2</b>	100 psia (6.9 bara), VTP only
<b>MP3</b>	300 psia (20.7 bara), VTP only
<b>MP4</b>	500 psia (34.5 bara), VTP only

Note: Put N/A in feature block 9 for VT.

Maximum operating pressure must not exceed the full scale of the pressure transducer if the VTP option is ordered or damage may occur.

Feature 10 : qTherm Dial-A-Gas Selection		
*Select three additional gases to be programmed into the instrument; Air is standard on the instrument and cannot be removed. qTherm gas is +/- 3.0% of full scale for all qTherm gases unless otherwise noted. Hydrogen is +/- 5.0% FS.		
qTherm Gas Code	Gas	Actual Gas Calibration Code
<b>0</b>	Air (Standard)	0
<b>1</b>	Argon	1A
<b>2</b>	Carbon Dioxide	2A
<b>3</b>	Chlorine	N/A
<b>4</b>	Digester Gas	4A
<b>6</b>	Helium	6A
<b>7</b>	Hydrogen	7A
<b>8</b>	Methane	8A
<b>10</b>	Nitrogen	10A
<b>11</b>	Oxygen (0.75% reading plus 0.5% full scale qTherm accuracy)	N/A
<b>12</b>	Propane	12A
<b>14</b>	Ammonia <sup>1</sup>	N/A
<b>99</b>	Other <sup>1</sup> —Consult Factory	99A

<sup>1</sup>Correlation calibration - consult Gas Table for accuracy.

Note: Accessories must be entered as separate line items on your order.

Option 1: Digital Communications	
<b>MB</b>	Modbus RTU full device description
<b>HART</b>	HART with full device description

Note: Available with cFMus, ATEX/IECEX

PARENT	FEATURES								DIAL-A-GAS				OPTIONS
	1	2	3	4	5	6	7	8	*9	10	11	12	1
780i	<input type="text"/>	<input type="text"/>	<input type="text"/>	<input type="text"/>	<input type="text"/>	<input type="text"/>	<input type="text"/>	<input type="text"/>	0	<input type="text"/>	<input type="text"/>	<input type="text"/>	<input type="text"/>

Instructions: To order a 780i, please fill in each feature number block by selecting the codes from the corresponding features below and following pages.  
 \*Feature 9 is air (always included)

Feature 1: Multivariable	
<b>VT</b>	Inline Thermal Mass Flow Meter with Flow Conditioning; all 316L stainless steel construction; linear 4-20 mA output signals for Mass Flow Rate and Temperature; temperature range -40°F to 392°F (-40°C to 200°C) and pressure to 500 psia (34.5 bar) maximum -1 NAA Only, (300 psig (20.7 barg) maximum for -2 or -3 agency approved units); standard accuracy +/- 0.5% of reading above 50% of full scale flow and +/- 0.5% of reading plus 0.5% of full scale below 50% of full scale flow; configurable alarm and pulse outputs; CE, cFMus, ATEX, and IECEx approved
<b>VTP</b>	Add a pressure output to the 780i VT version; three 4-20 mA linear outputs for mass flow velocity, temperature, and pressure; includes pressure sensor up to 300 psia (20.68 bar). Note: NAA NPT units can go up to 500 psia (34.5 bar).

Feature 2: Approvals	
<b>1</b>	<b>NAA.</b> Non-agency approved.
<b>2</b>	<b>cFMus.</b> Process Temperature Range: -40°C to 200°C (-40°F to 392°F). Class I, Division 1, Groups B,C, and D T3C Ta = -40°C to 60°C (-40°F to 140°F). Type 4x.
<b>3</b>	<b>ATEX and IECEx.</b> II 2 G Ex db IIC T3 Gb. II 2 D Ex tb IIIC T200°C Db. Ta = -20°C to 60°C (-4°F to 140°F). Process Temperature Range: -40°C to 200°C (-40°F to 392°F).

Feature 3: Inline Flow Bodies with Flow Conditioning	
<b>N2</b>	1/2-inch (1 cm) NPT male 316 SS
<b>N3</b>	3/4-inch (2 cm) NPT male 316 SS
<b>N4</b>	1-inch (2.5 cm) NPT male 316 SS
<b>N5</b>	1.5-inch (4 cm) NPT male 316 SS
<b>N6</b>	2-inch (5 cm) NPT male 316 SS
<b>N7</b>	3-inch (8 cm) NPT male 316 SS
<b>N8</b>	4-inch (10 cm) NPT male 316 SS
<b>N9</b>	6-inch (15 cm) NPT male 316 SS
<b>N10</b>	8-inch (20 cm) NPT male 316 SS

Feature 4: Electronics Enclosure	
<b>E2</b>	Hazardous-area location enclosure NEMA 4X (IP66) mounted directly on probe
<b>E4(10)</b>	10 feet away from the probe with junction box mounted on probe.
<b>E4(25)</b>	25 feet away from the probe with junction box mounted on probe.
<b>E4(50)</b>	50 feet away from the probe with junction box mounted on probe.
<b>E4(100)</b>	100 feet away from the probe with junction box mounted on probe.

Note: Customer may cut cable length with no effect on accuracy.

<b>F2</b>	1/2-inch ANSI class 150 flange 316 SS
<b>F3</b>	3/4-inch ANSI class 150 flange 316 SS
<b>F4</b>	1-inch ANSI class 150 flange 316 SS
<b>F5</b>	1.5-inch ANSI class 150 flange 316 SS
<b>F6</b>	2-inch ANSI class 150 flange 316 SS
<b>F7</b>	3-inch ANSI class 150 flange 316 SS
<b>F8</b>	4-inch ANSI class 150 flange 316 SS
<b>F9</b>	6-inch ANSI class 150 flange 316 SS
<b>F10</b>	8-inch ANSI class 150 flange 316 SS

Feature 5: Input Power	
<b>P2</b>	24 VDC +/- 10.0%
<b>P3</b>	100-240 VAC

<b>FD6</b>	DN50, PN16, flange
<b>FD7</b>	DN80, PN16, flange
<b>FD8</b>	DN100, PN16, flange
<b>FD9</b>	DN150, PN16, flange
<b>FD10</b>	DN200, PN16, flange

Feature 6: Output	
<b>V4</b>	Two linear 4-20mA outputs for T and mass flow rate
<b>V6 (VTP only)</b>	Three linear 4-20mA outputs for T, P, mass flow rate (only available with Feature 1: Multivariable 780i VTP)

<b>GD4</b>	DN25, PN40, DIN flange
<b>GD5</b>	DN 40, PN40, DIN flange
<b>GD6</b>	DN50, PN40, DIN flange
<b>GD7</b>	DN80, PN40, DIN flange

Feature 7: Display	
<b>DD</b>	Digital Display: UltraBright LCD indicates Mass Flow Velocity, T, P, Alarms and Totalized Mass Flow in engineering units; 6-push button user interface makes selection easy: Dial-A-Gas, change units, change language, set alarms and much more...
<b>DD-NRT</b>	Totalizer cannot be reset in the field.

Feature 8: Pressure	
<b>MP1</b>	30 psia (2.1 bar), VTP only
<b>MP2</b>	100 psia (6.9 bar), VTP only
<b>MP3</b>	300 psia (20.7 bar), VTP only
<b>MP4</b>	500 psia (34.5 bar), VTP only

Note: Put N/A in feature block 8 for VT.  
 Maximum operating pressure must not exceed the full scale of the pressure transducer if the VTP option is ordered or damage may occur. Note: NAA NPT units can go up to 500 psia (34.5 bar).



**Feature 9: qTherm Dial-A-Gas Selection**

\*Select three additional gases to be programmed into the instrument; Air is standard on the instrument and cannot be removed. qTherm gas is +/- 3.0% of full scale for all qTherm gases unless otherwise noted. Hydrogen is +/- 5.0% FS.

qTherm Gas Code	Gas	Actual Gas Calibration Code
0	Air (standard)	0
1	Argon	1A
2	Carbon Dioxide	2A
3	Chlorine	N/A
4	Digester Gas	4A
6	Helium	6A
7	Hydrogen	7A
8	Methane	8A
10	Nitrogen	10A
11	Oxygen (0.75% reading plus 0.5% full scale less than 50% qTherm accuracy)	N/A
12	Propane	12A
14	Ammonia <sup>1</sup>	NA
99	Other <sup>1</sup> —Consult Factory	99

<sup>1</sup>Correlation calibration - consult Gas Table for accuracy.

**Option 1: Digital Communications**

<b>MB</b>	Modbus RTU full device description
<b>HART</b>	HART with full device description

Note: Available with cFMus and ATEX/IECEX.

# Appendix B: Smart Interface Installation

## QuadraTherm 640i & 780i Smart Interface Program

### Install the RS-232 Cable or USB Cable

Install the provided RS-232 pigtail if so equipped, alternatively plug in the USB cable to the terminal board (TB) as shown below, then apply power to the meter.

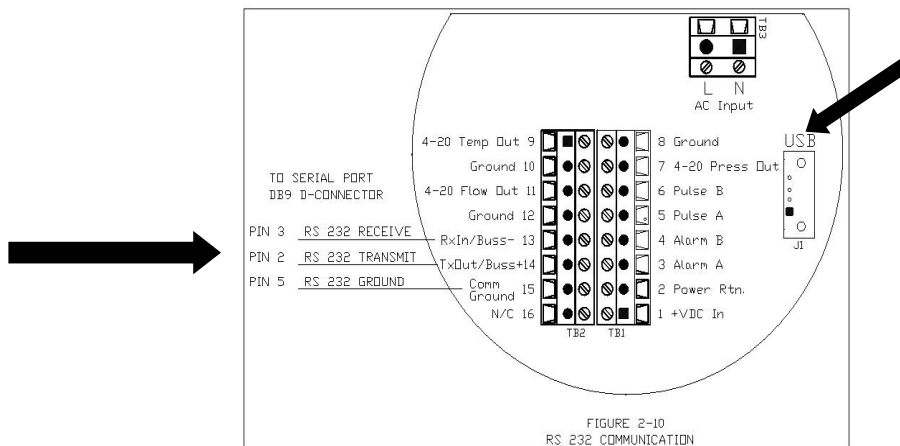

FIGURE 2-10  
RS 232 COMMUNICATION



### Installing the Program

#### System Requirements:

Operation System: Windows® XP and above

QuadraTherm 640i & 780i Sierra Interface Program (SIP):

Click on the file (640i & 780i Sierra Interface Program). This file is self-extracting.

Follow instructions for installing the files.

Process takes about 1-10 minutes total depending on speed of your computer.

QuadraTherm 640i & 780i Sierra Interface Program Windows Compatible

**Instructions:** Click on Setup let it install the 640i & 780i Smart Interface Program. If you have any questions about downloading the files please contact Tech Support at <https://www.sierrainstruments.com/techsupport/techsupport.html> .

### Program Start-up

The smart interface program allows the user to configure the unit and view all unit parameters.

**NOTE:** The current version of the program. You may obtain the latest version from <https://www.sierrainstruments.com/products/sip/sip-qt.html>

Make sure your meter is powered up and the meter is connected via the serial RS-232 or USB port to the computer running this SIP program. Click on the 640i and 780i SIP Icon to start the program.

Note select Port. To begin, use the pull down menu to select the appropriate com port. Once the port is selected and the password is entered, the meter data is read into the SIP program. Note how all data fields become populated. This may take several seconds. Be aware that all the data fields are read only. Entering and writing this data is done via the Function Selector or quick keys. The quick keys and Function Selector will be discussed in those sections.

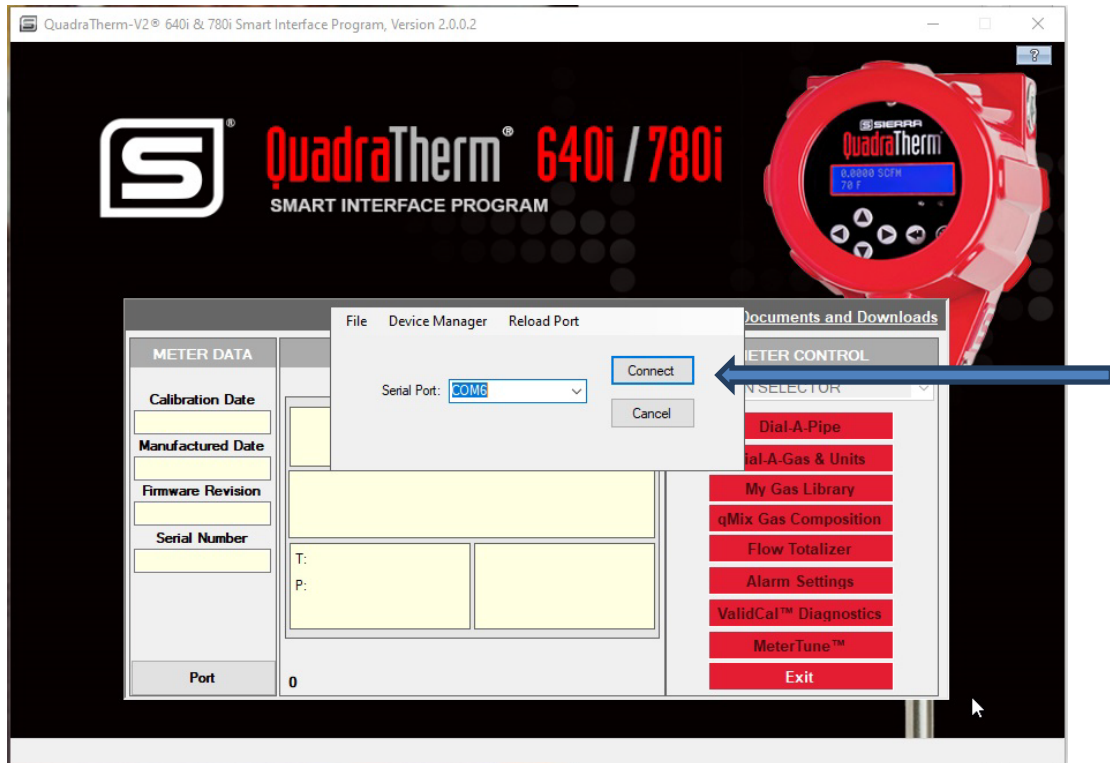

Enter the meter password, default is 0000 and can be changed using SIP.

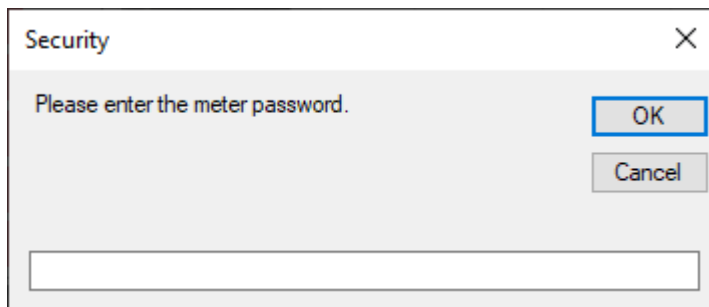

## Meter Data

The meter data shows the basic identifying data of the meter serial number, firmware and manufacture date. The calibration date represents the last time the meter was factory calibrated.

METER DATA	
<b>Calibration Date</b>	3/5/2024
<b>Manufactured Date</b>	3/5/2024
<b>Firmware Revision</b>	v2.0.50
<b>Serial Number</b>	123456

Factory recalibration is at the discretion of the end user. With Dial-A-Pipe and Dial-A-Gas technology the 640i/780i can be reconfigured to fit into a large variety of applications.

## Meter Display

The meter display shows the primary variables (mass flow, temperature, pressure and totalized flow), as well as what gas and pipe have been selected and the Full Scale flow. Both Dial-A-Gas and Dial-A-Pipe are field-configurable, offering unparalleled flexibility. Alarm status is also shown.

METER DISPLAY	
<b>Air</b>	FS: 364.81 SCFM PIPE: 2.0670 In
<b>0.0000 SCFM</b> 63.00 SCF	
T: 84.43 F P: 14.70 Psia	<b>Low Alarm: ON</b> 10.000 SCFM

In this example:

- The gas being measured is air
- The calibrated full scale (FS) is 364.81 SCFM
- The inside diameter of the pipe is 2.0670 Inches
- The meter is currently reading 0.0000 SCFM (there is no flow in the pipe)
- The meter has totalized 63.00 SCF (there WAS flow in the pipe at some point)
- The temperature is 84.63 °F
- The meter was purchased without the pressure option, so pressure is not active and the manually entered Process Pressure Value of 14.70 Psia is shown.
- The low alarm is set to energize at 10.0000 SCFM
- Since flow is 0.0000 SCFM, the alarm is ON indicating flow is below the 10.000 SCFM set point

## **Meter Control**

A series of quick keys, represented by the red keys, are provided to allow for rapid configuration of application conditions flow totalizer and alarm set-up

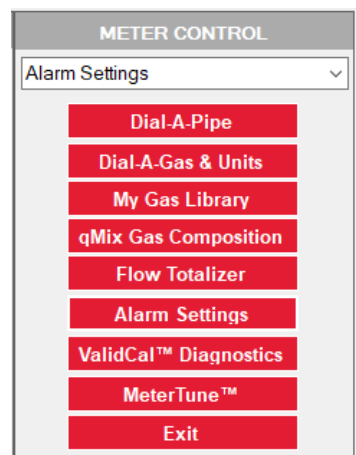

More detailed configuration can also be done using the function selector (in the above example currently showing Alarm Settings).

## **Quick Keys: Dial-A-Pipe**

The Dial-A-Pipe feature makes field configuration very convenient. You must know the type of pipe and either the pipe schedule or the inside diameter.

If inside diameter is known, select Other Pipe Schedule and the units from the diameter units menu and type in the number in the Inside diameter field.

If the pipe schedule is known, select it from the pipe schedule pull down menu. The inside diameter will then be auto-populated with the correct value (in the units as selected in the Diameter Units drop-down menu).

Finally, use the pipe type pull down menu and select the type.

In the example below we have selected 4-inch ANSI Schedule 40. The program knows this has an inside diameter of 4.0260 inches. We have selected ss-smooth (stainless steel-smooth inside wall)

as the closest match to our application.

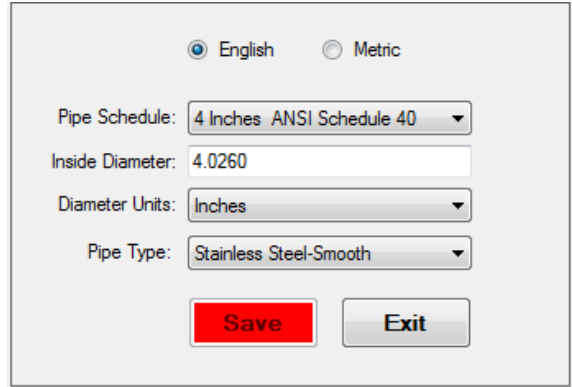

A dialog box for pipe configuration. At the top, there are two radio buttons: "English" (selected) and "Metric". Below are four dropdown menus: "Pipe Schedule" (4 Inches ANSI Schedule 40), "Inside Diameter" (4.0260), "Diameter Units" (Inches), and "Pipe Type" (Stainless Steel-Smooth). At the bottom are two buttons: "Save" (red) and "Exit" (grey).

### ***Quick Keys: Dial-A-Gas and Units***

As with Dial-A-Pipe, Dial-A-Gas is another powerful feature of the 640i/780i. Simply select the gas to be measured from the pull-down menu. The menu can support 4 different gases and can be updated from Sierra's gas-properties library and qMix Gas Composition as new gases and mixtures are added.

The Dial-A-Gas and Units quick key also allows the selection of flow, temperature and pressure units. Simply select the desired units from the pull down menus. If you need other gases in the future, use the My Gas Library, qMix Gas Composition, or contact the factory and we can download updates from our gas library.

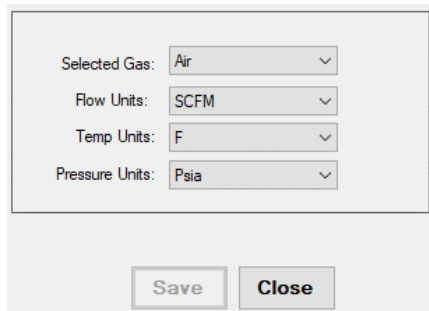

A dialog box for gas and unit configuration. It contains four dropdown menus: "Selected Gas" (Air), "Flow Units" (SCFM), "Temp Units" (F), and "Pressure Units" (Psia). At the bottom are two buttons: "Save" and "Close".

## My Gases Database

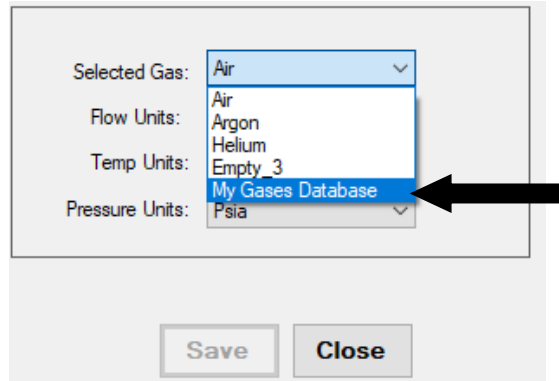

Selecting My Gases Database from the Dial-A-Gas pull down menu allows users to access Sierra's unique Dial-A-Gas library. Our library is continually growing and expanding. As Sierra calibrates more and more gases with the 640i and 780i, we are able to improve the accuracy of our current qTherm gases and add new ones. These new or improved gases are available for download from our My Gases Database/ My Gas Library, and can then be uploaded into your 640i or 780i as a replacement gas for any of the three slots available (remember Air is always in slot 1 and is NOT replaceable).

To start the My Gases Database, select "My Gases Database" from the drop down menu. You can also open this screen from the My Gas Library Quick Key. This will bring up the following screen:

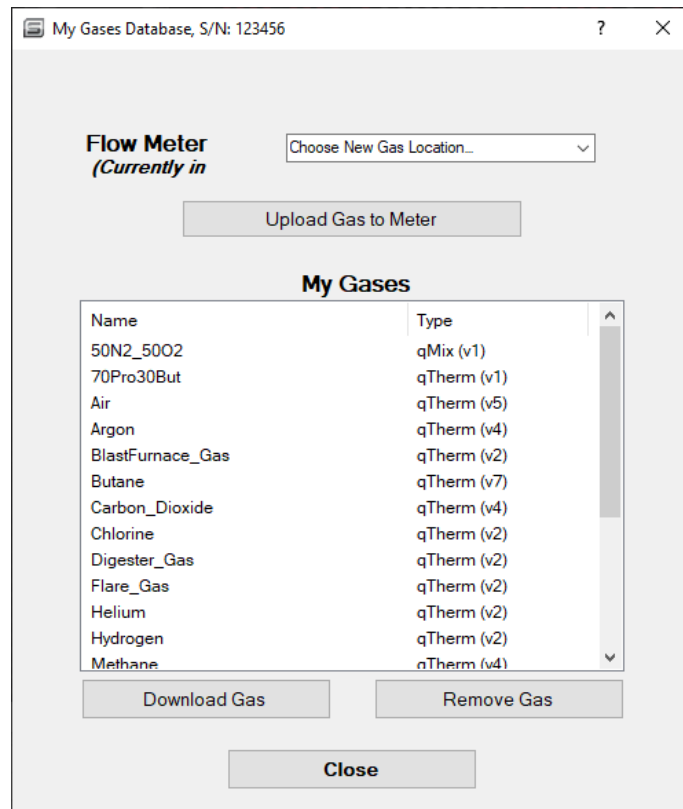

### **Local Gases**

All Gas Files saved on your computer are displayed in the 'My Gases' window. These are not necessarily the gas files in your meter, but ones you have downloaded from the Sierra Server previously. If you have never done so, this area will be blank.

Most recent version files are saved in c:\sierrainstruments\640i\gas  
Older versions are stored in c:\sierrainstruments\640i\gas\archive

### **Remote Gases**

By clicking the 'Download Gas' button, the Sierra qTherm® Gas Database window is populated with gas files available for download. You must have an internet connection to connect to the Sierra server.

If the gas file is a newer version than a corresponding local file or is not present locally, then it appears in red. Files that are already saved locally are black.

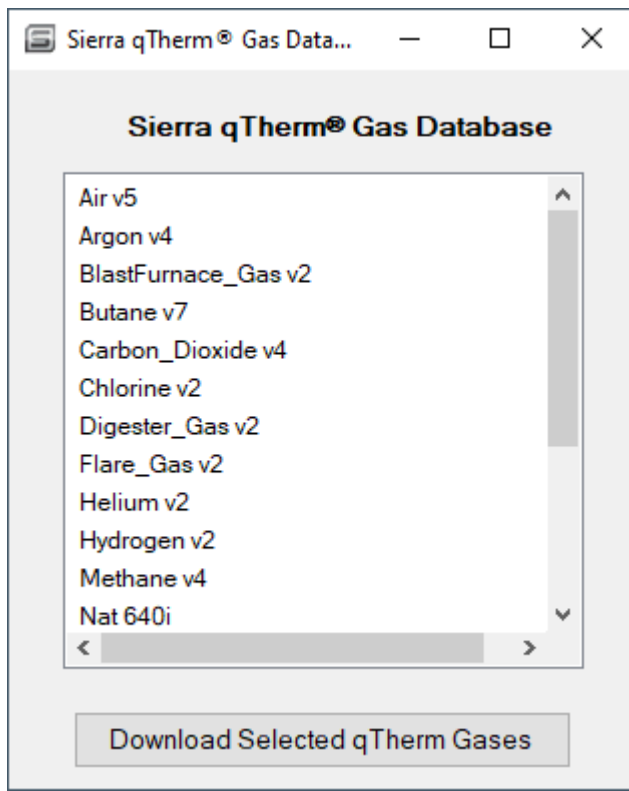

### **Download Gas File**

To download a remote gas file, the file is selected in the Sierra qTherm Gas Database window and the "Download Selected qTherm Gases" button is clicked. Once the download is completed, the gas file will appear in the My Gases window and will no longer appear as red in the Sierra qTherm Gas Database window.



If a new version of a gas file is downloaded, the older local version is moved into the Archive directory.

### **Load Gas**

To load a gas into one of the 3 available slots (Air is in Slot 1 and cannot be changed), select the gas to be replaced in “Chose New Gas Location” dropdown on the top and click the “Upload Gas to Meter” button. You will see a progress bar and then a message indicating the upload status. Upon completion your old qTherm gas will have been replaced!

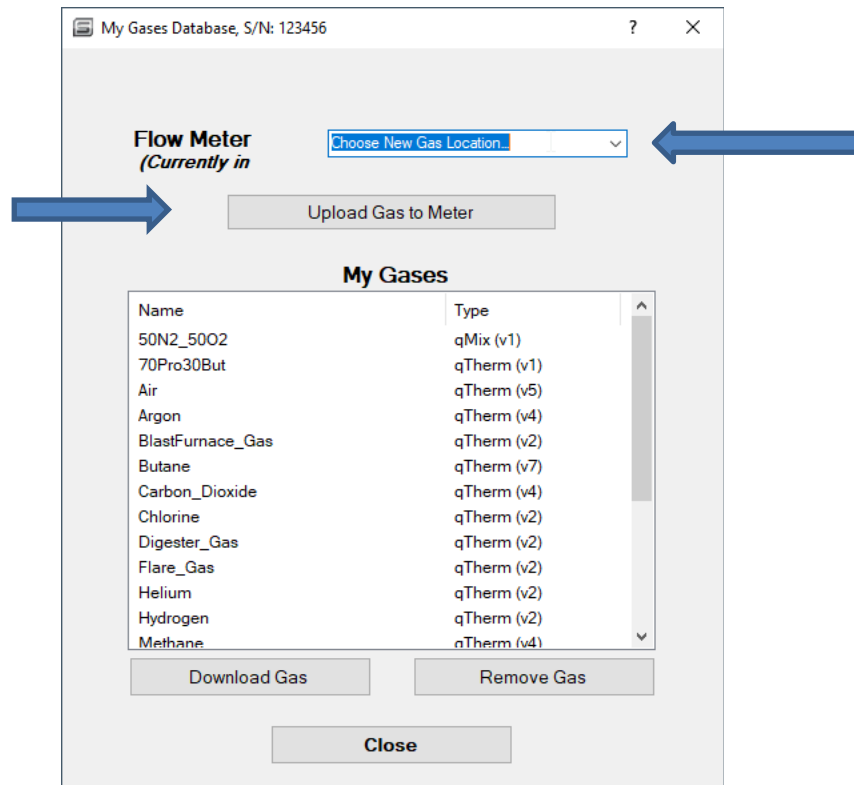

### **Quick Keys: qMix Gas Composition**

See qMix Gas Mixing Feature Instruction Manual here:

<https://www.sierrainstruments.com/userfiles/file/manuals/qmix-instruction-manual.pdf?x=8012>

### **Quick Keys: Flow Totalizer**

#### **Flow Totalizer Setup/Reset**

If units are not mass flow, it will not turn on. The totalizer will totalize accumulated flow if it is turned *on*. Turn it on or off with the Totalizer Status drop down menu.

Use “Force Totalizer Relay Pulse” to test pulse relay.

**NOTE:** *The totalizer operates at a maximum frequency of 1HZ (1 pulse per second). This limits the maximum units per pulse.*

For example, you have a flow of 60 scfm with a units-per-pulse set to 1 SCF This means 1 pulse per second or 1 Hz. This is within the ability of the totalizer.

Reducing the flow to 30 scfm means the totalizer will pulse once every two seconds. Again this is OK.

Increasing the flow to 120 scfm means the totalizer would pulse once every 0.5 sec, but this is too fast.

The totalizer will not count correctly and may even continue to count when the flow drops to zero.

This puts a limit on the resolution of the totalizer at higher flows. You must convert the flow to units per second and ensure this number is equal to our bigger than one.

The pulse itself is a negative going square wave pulse. The duration of the pulse can be set with the pulse width value.

The Totalizer Unlocked feature allows you to lock and prevent the ability to turn on or off the Totalizer from the Display keypad menu to prevent tampering. Uncheck this box to activate this feature.

The Allow Fullscale Clipping feature allows the customer to opt out of totalization in situations where there is an over range. This can occur, for instance, with heavy moisture or water in the pipe, or in an upset condition. The totalizer continues to totalize internally, but can only put out one pulse per second, so it stores them up and continues to output them long after the condition is corrected. Check this box to activate this feature.

Reset the Totalized Flow using the “Reset Totalizer” button (This function is disabled on meters requiring non-resettable totalizers).

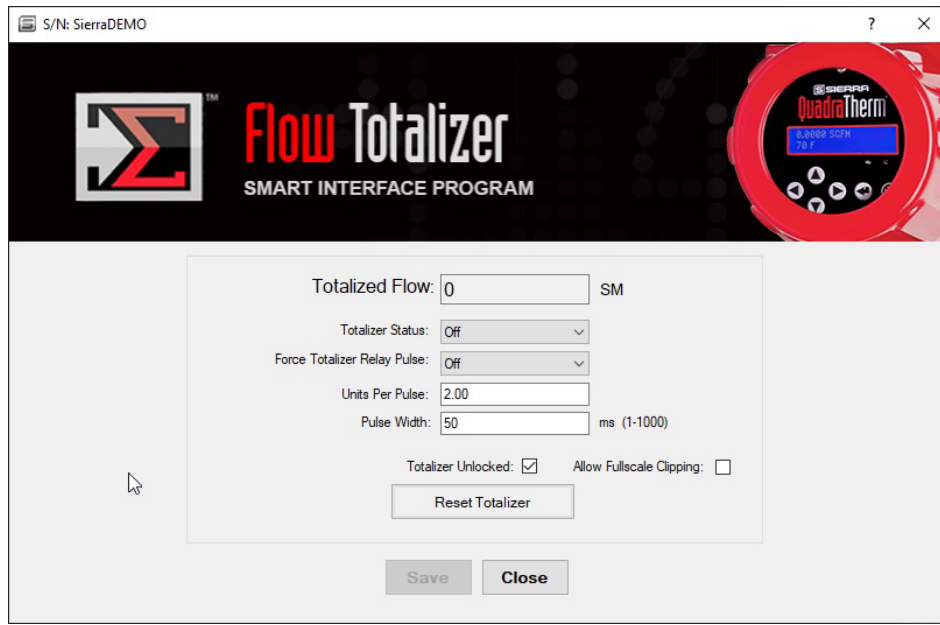

## Quick Keys: Alarm Settings

Pressing the Alarm Settings Quick Key brings up the following details about the alarms:

Active:	Off	▼	
Mode:	Low	▼	
Alarm Status:	OFF		
	Low	High	
Flow:	10.000	400.00	SCFM
Temperature:	70.000	80.000	°F
Pressure:	14.000	30.000	Psia
Totalizer:	5	30	SCF

Only **one** alarm can be active at any time. Use the Active pull down menu to select the active alarm or to turn off the alarm function entirely.

Active: Flow ▼  
Mode: Off  
Alarm Status: Flow  
Pressure  
Temperature  
Totalizer

Low High  
Flow: 50.0000 89.0000

Once you have selected the active alarm, use the Mode pull down menu to select whether the meter should alarm on low, high or to set an alarm window. A window alarm will turn on once the parameter drops below the low alarm or exceeds the high alarm setpoints, so it serves as a combination low and high alarm (the alarm is off when the active parameter is within the “window”).

Active:	Flow	▼	
Mode:	Low	▼	
Alarm Status:	ON		
	Low	High	
Flow:	10.000	400.00	SCFM
Temperature:	70.000	80.000	°F
Pressure:	14.000	30.000	Psia
Totalizer:	5	30	SCF

You may now enter the alarm low and high values. To enter, click on the field and type in the numeric values for the desired alarm. Hit save and the entered value will be written into memory.

In the example above, flow is selected as the Active alarm. We have indicated we want the alarm to activate in Low Flow mode, and we want the alarm to activate at 10.0000. The units as set up in the units menu are in SCFM, so once flow drops below 10.000 SCFM we should see an alarm condition.

## Quick Keys: ValidCal™ Diagnostics

ValidCal™ Diagnostics is a complete meter diagnostics suite. It tests all analog outputs, relays and primary variable measurements.

ValidCal™ Diagnostics sensor validation is designed to be performed in AIR under ambient conditions (room temperature and pressure) It must be performed under *no flow* conditions. The meter must be removed from the pipe if possible, and the Sierra end cap placed over the sensor. The test may be performed in the pipe provided these same conditions are met while the probe tip is inside the pipe.

S/N: SierraDEMO

**ValidCal™ Diagnostics**  
SMART INTERFACE PROGRAM

Date: 10/16/2024      FLOW: SMPS      TEMPERATURE: °F      PRESSURE: Psia

**3.810**      **171.69**      **14.70**

**TEMPERATURE SENSOR**

T2:  T3:  T4:

**Validate**

**FLOW SENSOR**

Reference Flow Watts:

Flow Meter Actual Watts:

**Validate**

**PRESSURE SENSOR**

Meter Pressure:  Psia

External Pressure:  Psia

**Validate**

**ALARM / TOTALIZER RELAY**

Alarm Relay Test   Passed  Failed

Pulse Totalizer Relay Test   Passed  Failed

**4 - 20 mA VALIDATION OUTPUT**

Flow: **Test 4 mA**  **Test 20 mA**

Temperature: **Test 4 mA**  **Test 20 mA**

Pressure: **Test 4 mA**  **Test 20 mA**

**Low/High FTP**      **Print**      **Close**

If any of the tests fail, follow the troubleshooting tips below and the more general ones contained in chapter four of this manual.

## 4-20 mA Output Validations

The 4-20 mA output validation allows users to force a 4 or 20 mA output on all three analog outputs. To test:

Hook a DMM (select DC current) to the +/- terminals of the output you are validating:

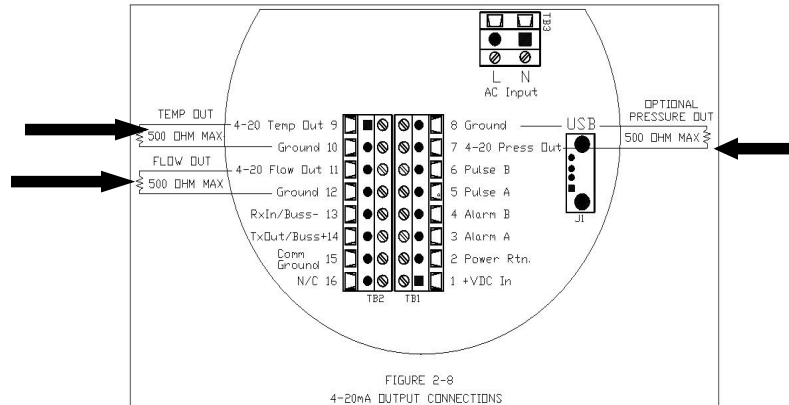

Press Test 4 mA and enter the value from your DMM (should be around 4.000 mA)

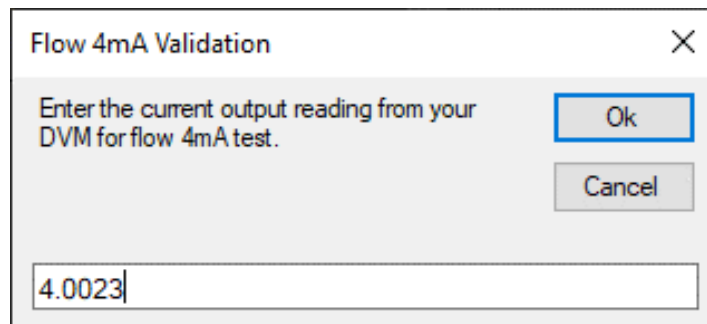

The program will show passed provided the reading is within tolerance. If it shows failed, please contact the factory for assistance. Repeat this procedure for all remaining 4- 20 mA tests. The most common failure is that the 4- 20 mA wires have become loose or that the DMM is incorrectly set up (must be set up for measuring direct DC current in the mA range).

The 4 to 20 mA DAC counts may be adjusted by going to the "4-20mA Output Setup" in the function selector.

## Flow Sensor Validation

This routine tests the flow sensor and sensor drive circuitry by measuring the Watts required to heat the velocity sensor to a value of 50°C above the current temperature of the sensor.

The reference flow Watts is the watts required at the time of calibration to attain this 50°C *overheat*. Barring damage or drift, this value should remain relatively constant over time.

**FLOW SENSOR**

Reference Flow Watts:

Flow Meter Actual Watts:

**Validate**

Selecting the FLOW SENSOR Validate button will start the test.:

The test will automatically begin. Look at actual temperature. It will begin increasing as watts are added to the flow sensor, heating it up to 50 °C (122 °F). Once this temperature reaches set point, the test will complete itself, usually within 5 minutes. If the Reference Flow Watts is within tolerance of Flow Meter Actual Watts, the meter will pass validation. If the test fails, ensure you have allowed adequate time for the sensor and probe to stabilize before starting the test, that the probe tip is covered and that you began the test with no flow present and at room temperature and pressure. True sensor failures are rare and will be covered by Sierra’s lifetime sensor warranty.

### **Temperature Validation**

This routine checks the QuadraTherm gas temperature sensors (T2, T3 and T4). Select Validate Temperature Sensor. The readings should be roughly the same. Note it can take up to 20 minutes for the probe tip to cool to the surrounding temperature once it has been removed from the pipe. This is the most common “failure”. Allow the probe tip to cool and repeat the test.

Temperature Sensor Validation

Since the meter has a heated element, this will typically be hotter than ambient (room) temperature. Note it takes up to 20 minutes for the sensors to cool down after the heated element is turned off.

19:36

**Cancel Test**

### **Pressure Sensor Validation**

This routine validates the gas pressure sensor. Select validate pressure sensor, then enter the pressure in the pipe or test area as read by another external device (not the Sierra flow meter) in the pop-up window. The readings should be roughly the same. If there is no pressure transducer, the Screen will appear as below.

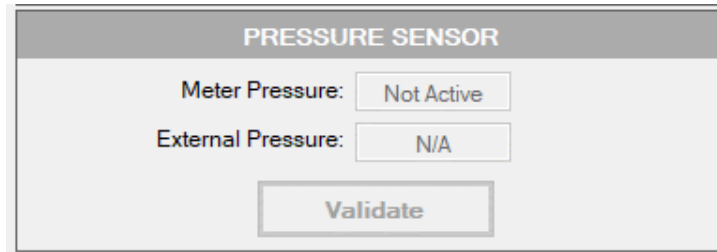

The typical failure for a pressure transducer is if it has been over pressurized and the pressure sensor membrane has burst or been damaged. Your pressure transducer has a burst pressure of 4 times and a pressure overload of 3 times its operational rating. For example, an MP2 100 psia sensor has a burst pressure of 400 psia and a pressure overload of 300 psia

### **Alarm/Totalizer Relay Validation**

This routine tests the Alarm and Totalizer relays.

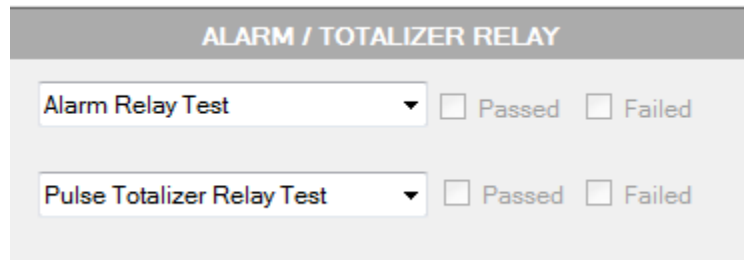

### **Test Alarm Relay**

Hook up a DVM as shown across the Alarm A and B terminals:

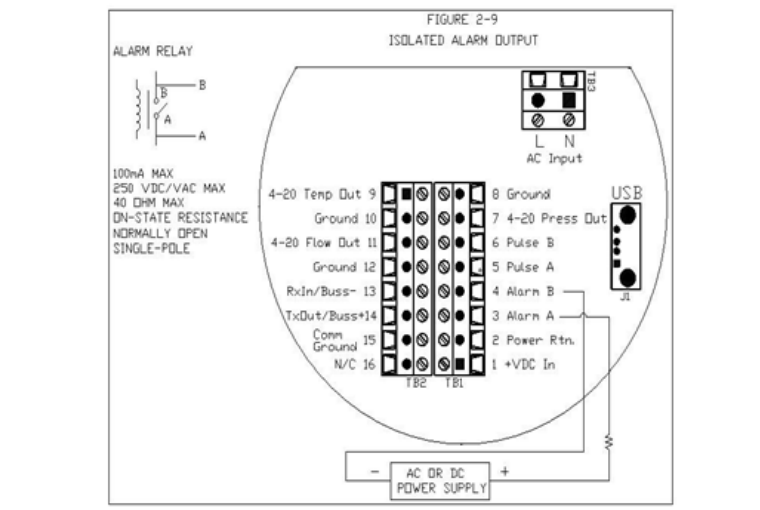

Use the pull down menu to select relay Open and close and use your DVM to check the relay.

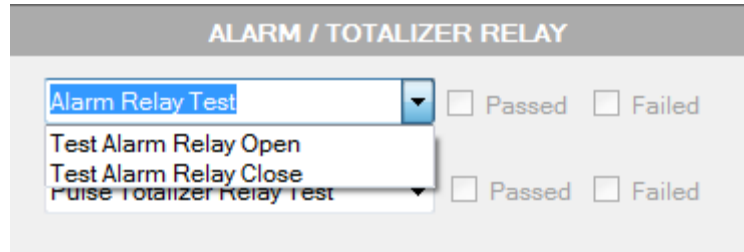

### Test Totalizer Relay

Hook up DVM as shown across the Pulse A and B terminals:

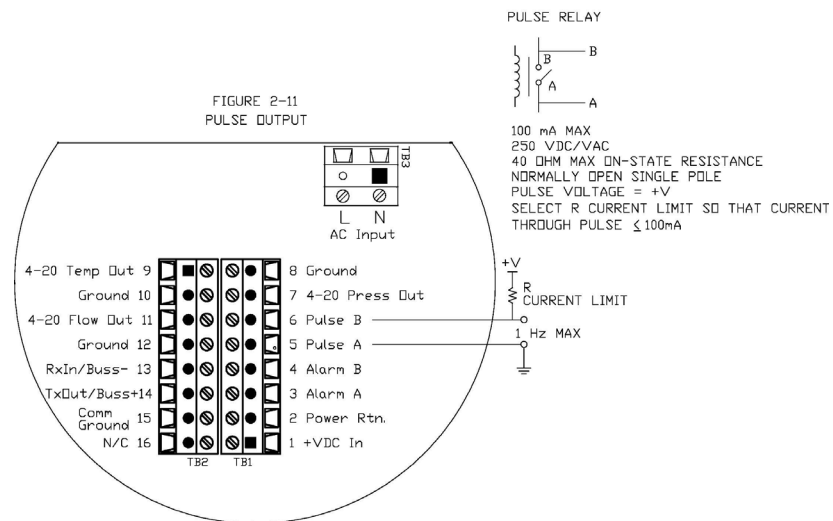

Turn on the totalizer relay test pulse and use your DVM or external counter to check the relay. The test pulse frequency is 1 Hertz.

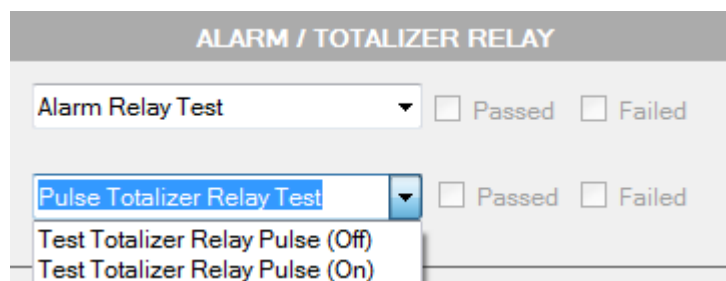



## Low/High FTP

Pressing the Low/High FTP button (located at the bottom left of the main ValidCal Diagnostics screen) brings up the following data screen. It shows the lowest and highest flow, velocity, temperature and pressure the meter has experienced since the last reset. This information is valuable in documenting events that might have caused meter damage, such as blowing out the pressure transducer or severely overheating the sensor.

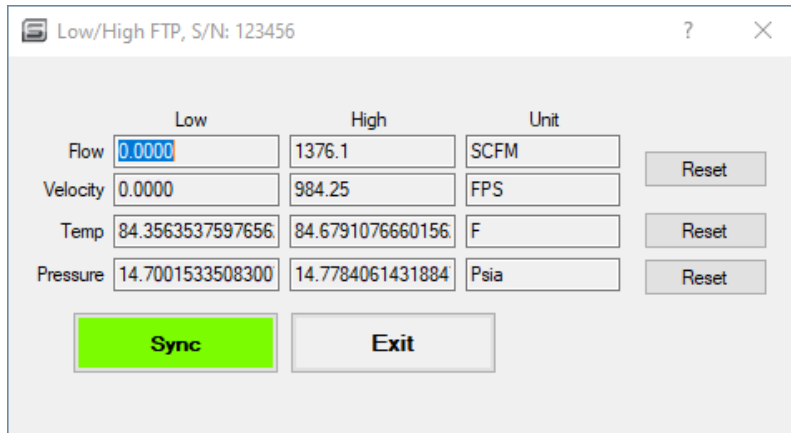

The screenshot shows a window titled "Low/High FTP, S/N: 123456". It contains a table of data with columns for "Low", "High", and "Unit". There are also "Reset" buttons for each row and "Sync" and "Exit" buttons at the bottom.

	Low	High	Unit	
Flow	0.0000	1376.1	SCFM	Reset
Velocity	0.0000	984.25	FPS	Reset
Temp	84.3563537597656	84.6791076660156	F	Reset
Pressure	14.7001533508300	14.7784061431884	Psia	Reset

Buttons: Sync, Exit

## Quick Keys: Meter Tune (Span)

Meter Tune (Span Adjust) allows you to fine tune your meter reading to match other devices or expectations. Simply enter the reading from the other device and the meter span will be auto adjusted to make the readings the same. Alternatively, you can directly edit the Span Adjust value, like entering 0.97 or 1.03 to affect the indicated flow value.

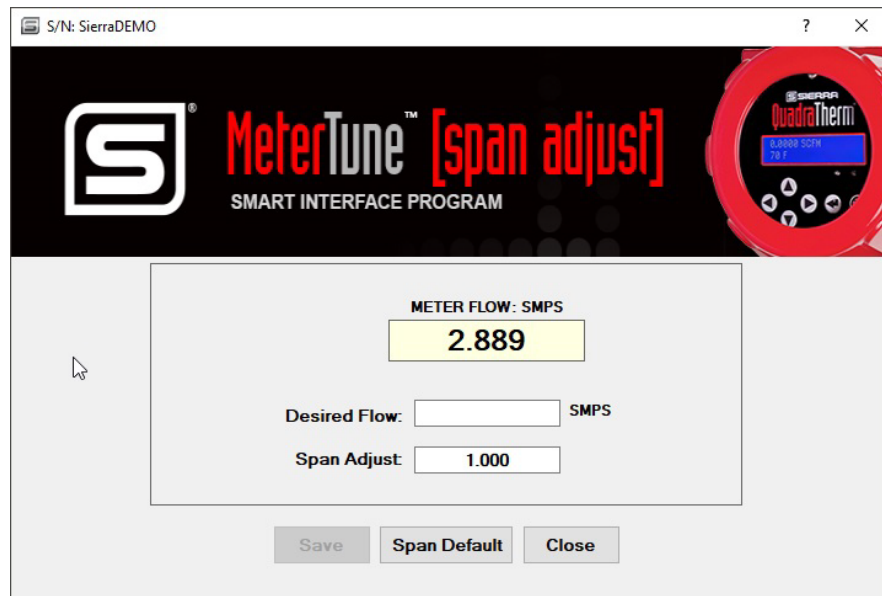

The screenshot shows a window titled "S/N: SierraDEMO". It features the Sierra logo and the text "MeterTune™ [span adjust] SMART INTERFACE PROGRAM". A red circular image of the meter is in the top right. The main display shows "METER FLOW: SMPS" with a value of "2.889". Below this are input fields for "Desired Flow: SMPS" and "Span Adjust: 1.000". At the bottom are "Save", "Span Default", and "Close" buttons.

METER FLOW: SMPS  
2.889

Desired Flow: SMPS  
Span Adjust: 1.000

Buttons: Save, Span Default, Close

## Quick Keys: Exit

Exit will immediately close the program. Any unsaved data will be lost.

## Function Selector

The function selector does all of the same things the quick keys do, while giving deeper access to some functions. To operate the selector, pick the desired function from the drop-down menu and left click.

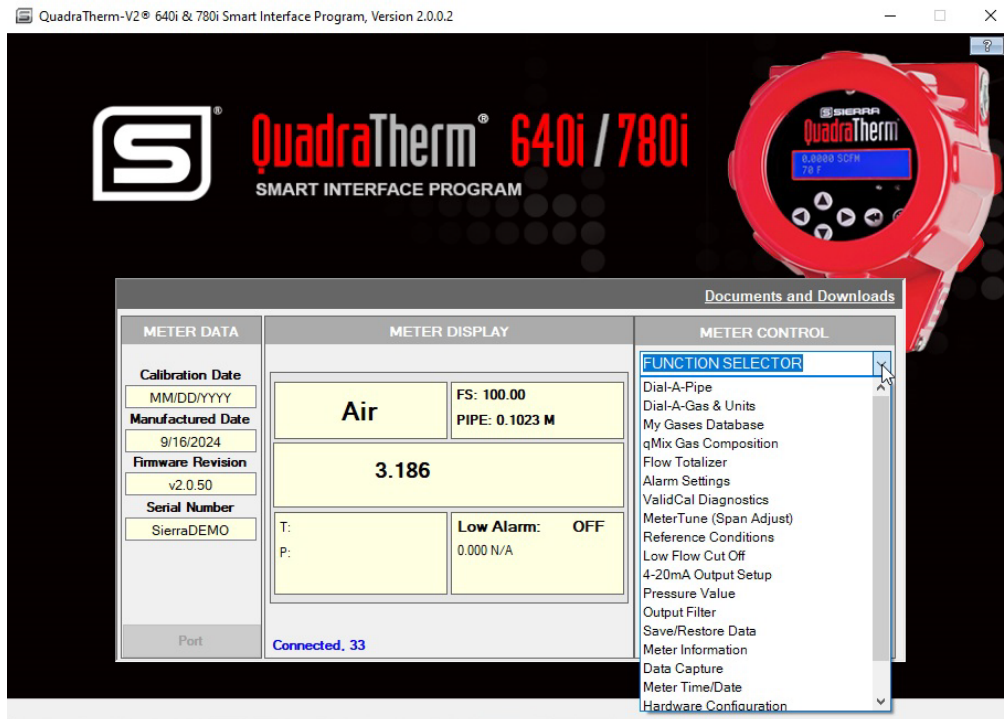

## Dial-A-Pipe

See Dial-A-Pipe Quick Key Description

## Dial-A-Gas and Units

See Dial-A-Gas Quick Key Description

## My Gases Database

See My Gases Database Quick Key Description

## qMix Gas Composition

See qMix Gas Mixing Feature Instruction Manual here:

<https://www.sierrainstruments.com/userfiles/file/manuals/qmix-instruction-manual.pdf>

## **Flow Totalizer**

See Flow Totalizer Quick Key Description

## **Alarm Settings**

See Alarm Settings Quick Key Description

## **ValidCal Diagnostics**

See ValidCal Quick Key Description

## **MeterTune (Span Adjust)**

See MeterTune Quick Key Description

## **Reference Conditions**

This function allows the user to enter the normal and standard temperatures and pressures to which gas MASS flows are referenced. Typically this is 70°F and 1 atmosphere in the USA (f.i. standard conditions as used in scfm: standard cubic feet per minute) or 0°C and 1 atmosphere in Europe (f.i. normal conditions as used in nlpm: normal liters per minute).

Reference Conditions, S/N: 123456

**STANDARD**

Temperature: 70.000 F

Pressure: 14.696 Psia

**NORMAL**

Temperature: 0.000 C

Pressure: 101.325 KPa A

Save Close

## **Low Flow Cut Off Value**

Due to thermal gradients, movement of gas molecules in the pipe can occur even with all valves shut. The Zero Cut Off forces both analog and digital outputs to zero at a percentage of the full scale. The Zero Cut off can be set to from 0 to 10.00% FS (full scale), meaning anytime the measured flow drops below this value the analog and digital outputs will be forced to zero. Totalization will not occur.

Full scale is the maximum flow rate for which the meter was calibrated. Exceeding it will not damage the meter, but flow readings will not be accurate. The calibrated full scale is found in the SIP main screen METER DISPLAY section.

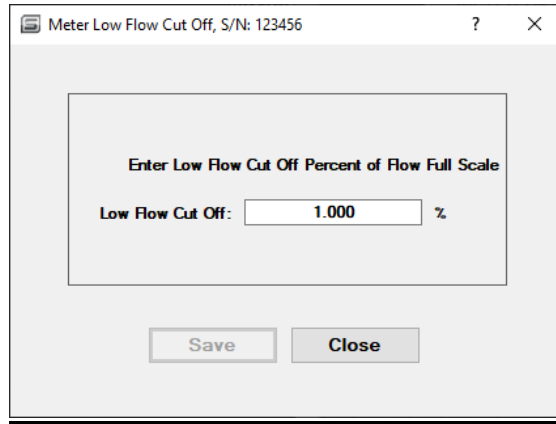

### **Flow/Pressure/Temperature 4 – 20 mA Output Setup**

This function allows you to set up the analog outputs. The 640i and 780i comes standard with linear 4-20 mA analog outputs for flow and temperature. If the meter is orders with pressure, a third analog output for pressure is available. For flow, 4 mA is always = 0 flow. The user may select 20 mA to equal any value up to the calibrated full scale. Full scale is the maximum flow rate for which the meter was calibrated. Exceeding it will not damage the meter, but flow readings will not be accurate. The calibrated full scale is the original value shown below for 20 mA or on the Calibration Certificate . Note the meter will still read digital flow values up to the calibrated full scale, but analog outputs will be scaled per the user settings. The Test Fail and Test >FS buttons are the SIL related tests for Flow 4-20mA output fault signaling.

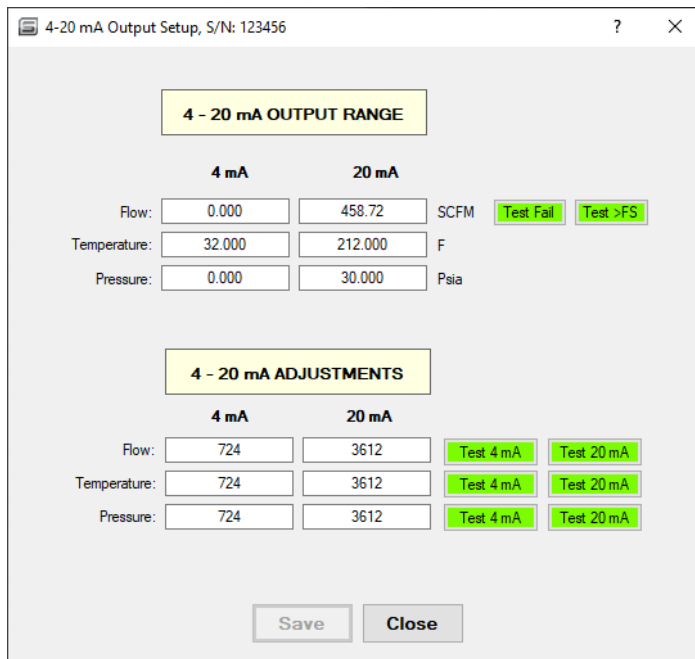

Pressure and temperature may be scaled as the user desires.

All units are as set in the units menu. The 4 and 20 mA analog outputs can be adjusted by adjusting the DAC counts until 4 or 20 mA is observed. For example if the flow 4 mA output is actually

reading 3.98 mA, adjust the DAC counts up from 724 and press test and repeat until the readings has increased to 4.00 mA.

### ***Pressure Math Value***

This is the pressure used by the qTherm math to calculate gas properties. This makes gas properties calculations more accurate. This value only needs to be updated with the process gas pressure on a VT unit as a VTP unit uses the actual pressure value from the xdcr.

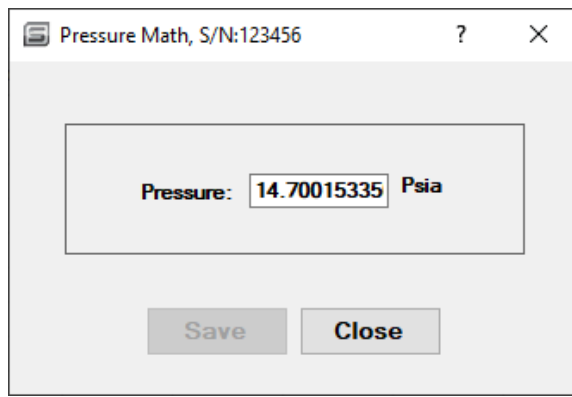

### ***Output Filter***

Use this screen to view or change your current Output Filter value. This value is a smoothing or averaging function of the indicated flow rate. This value can be from 1 to 200. Increasing this value will smooth-out the indicated flow rate more and slow down the time response slightly. Decreasing this value will make the indicated flow noisier, but will also speed up the response time slightly.

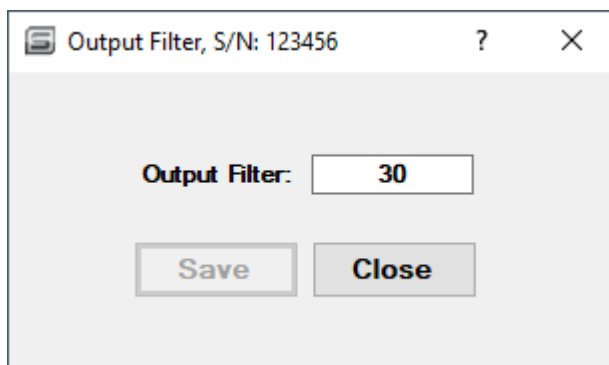

### ***Save/Restore Data***

This screen allows users to:

- Reboot (restart) the meter
- Restore Factory (Restores the meter to factory default (undoing any changes))
- Reflash the firmware
- Close Menu

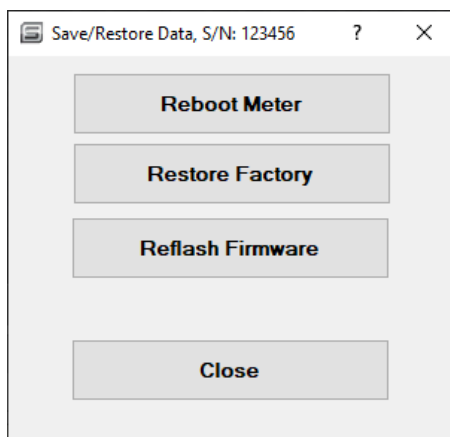

### ***Reflash Firmware***

- The meter (Main PCA) can be flashed to latest firmware version without losing any data. (Plug SIP USB cable into Terminal PCA)
- The meter (Display PCA) can also be flashed to latest firmware version without losing any data. (Plug SIP USB cable into Display PCA)
- This allows for any improvements or fixes to be applied in the field with no application interruption. Process takes approximately 5 minutes to fully upgrade meter, making it “offline” until it’s done, proceed with Caution.
- The firmware file is required. Latest available firmware is available on our website. The current main and display PCA firmware is part of SIP.

### ***Upgrading Firmware***

The QuadraTherm 640i/780i product line supports the ability for the user to upgrade their meter using the provided “Bootloader” tool. This tool is accessible through the “Function Selector” menu under the “Save/Restore Data” menu selection option.

1. To start the firmware upgrade process, select the “Reflash Firmware” button. If the system successfully connects to the meter, you will see a “Bootloader Version” number (1.40 shown in image below). The meter is ready to install the new firmware file at this point.

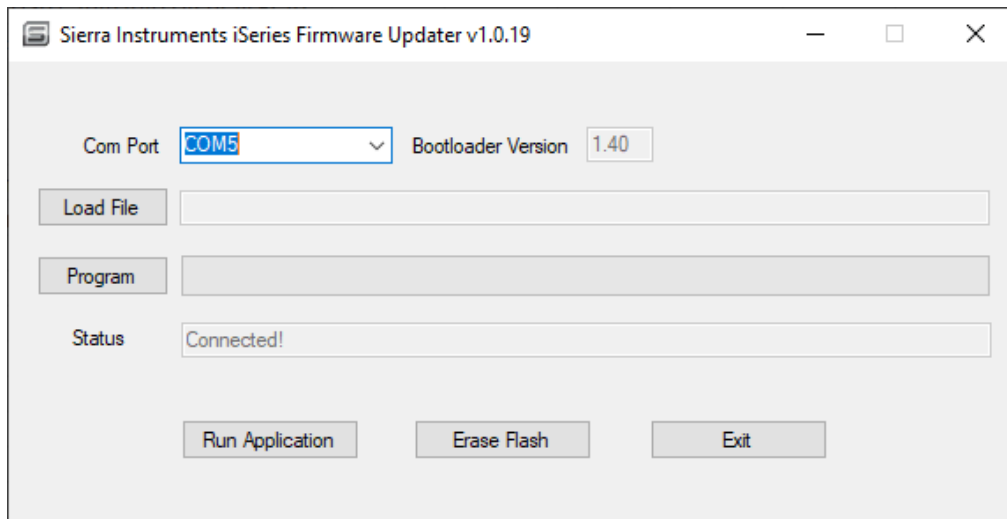

2. Next, select “Load File” button and it automatically will point to the latest HEX files for the Main and Display pca, you must select the correct one.
3. Now select “Open” and then select “Program.” At this point, the meter will now start the upgrade process. Upgrade process can take up to five minutes to complete.

### ***Meter Information***

Meter information allows you to view data about the meter and to customize the Password and Tag Number.

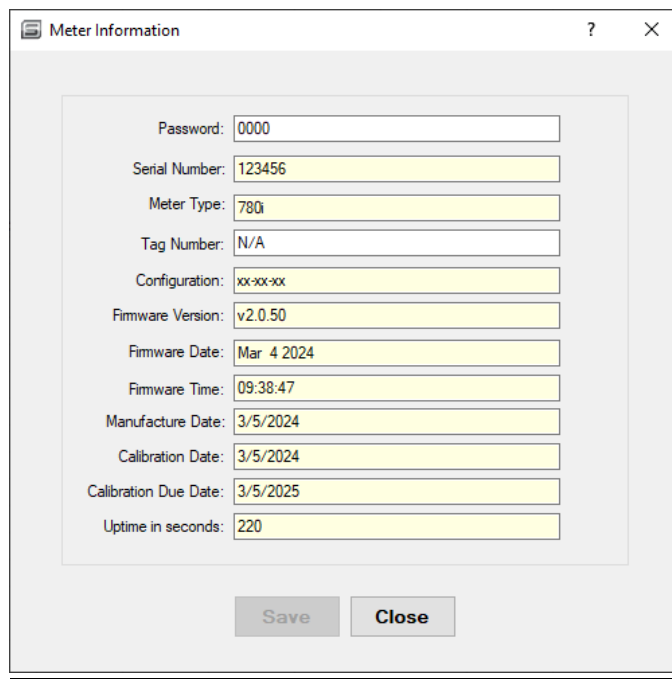

## Display Language

Sierra's qTherm Language Library is continually updated as our meter firmware is translated into other languages. These languages can be downloaded from the Sierra server.

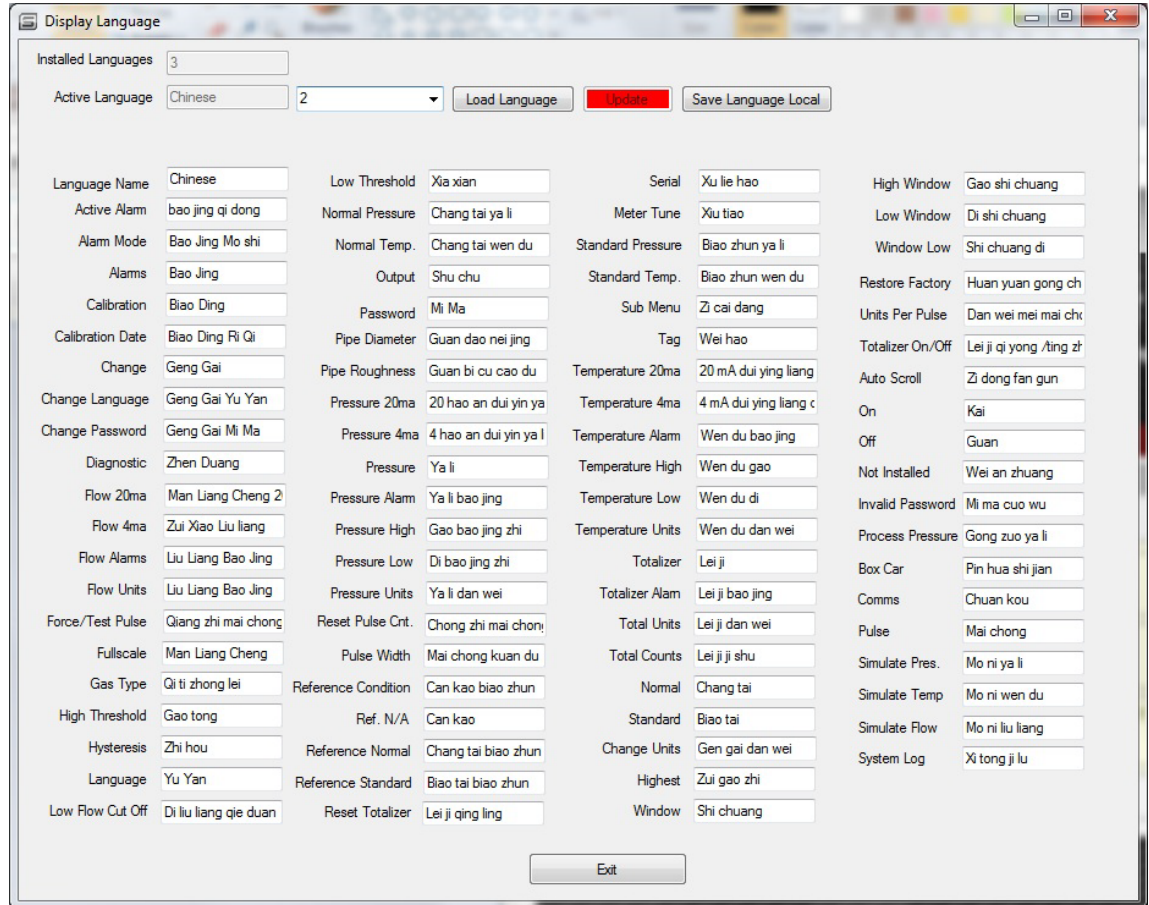

## Local Languages

All Language Files saved locally on your computer are displayed in the 'Language Library' window most recent version files are saved in C:\Sierrainstruments\640i\lang Older versions are stored in C:\Sierrainstruments\640i\lang\archive

## Remote Languages

By clicking the 'Load Language' button, the Remote Languages window is populated with language files available for download. You must be hooked up to the internet so you can download these files from the Sierra Server. If the language file is a newer version than a corresponding local file or is not present locally, then it appears in red. Files that are already saved locally are black.



### **Download Language File (Arrow Button)**

To download a remote language file, the file is selected in the Remote Language window and the arrow button is clicked. Once the download is completed, the language file will appear in the Local Languages window and will no longer appear as red in the Remote Languages window. If a new version of a language file is downloaded, the older local version is moved into the Archive directory.

### **Load Language**

Three language slots are available. To upload a new language to the meter, select the language you want to replace from the drop down menu, then select the language to upload from the local languages list, then press load Language. The language is uploaded to the meter and is available for use.

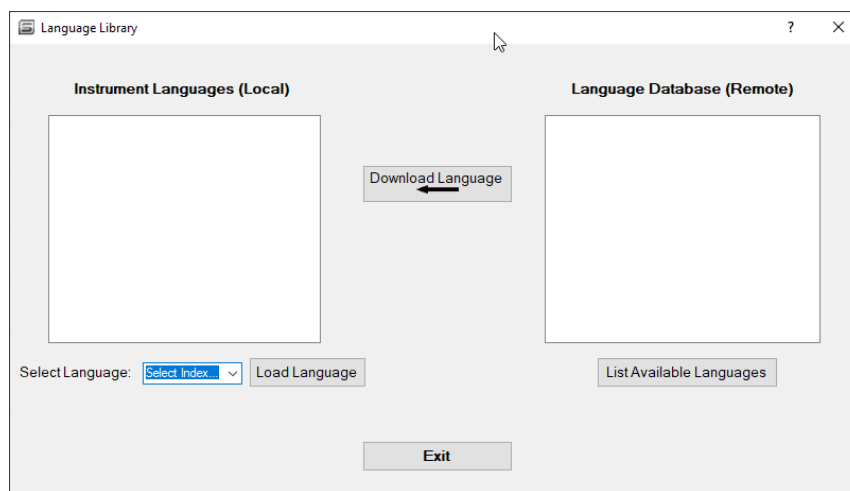

### **Data Capture**

The "Data Capture" menu allows you to log all the most important meter inputs and outputs and store in a .CSV file for reference.

1. Simply enter the Target Flow Rate and click the "Acquire Data" button to log a data point.
2. If you would like to specify a polling interval for logging data, just click the "Poll every" checkbox and choose the time interval from the dropdown menu.
3. Click the "Acquire Data" button to begin polling, and the "Stop Data Acquire" button when finished.
4. All data will be stored in a .CSV file located at

C:\SierraInstruments\640i\Data\{SerialNumber}.csv

### ***Meter Time/Date***

Press Update Current Time button to update the time.  
 Press Update Current Date to update the date.

### ***Hardware Configuration***

If your unit was ordered with the MODBUS option this is used to setup MODBUS Baud rate and Address values. See 640i/780i MODBUS manual for more information.

### ***Reflash Meter***

See Reflash Meter section above.

## ***Appendix C: Warranty Policy***

### ***Limited Warranty Policy- Register Online***

All Sierra products are warranted to be free from defects in material and workmanship and will be repaired or replaced at no charge to Buyer, provided return or rejection of product is made within a reasonable period but no longer than one (1) year for calibration and non-calibration defects, from date of delivery. To assure warranty service, customers must register their products online on Sierra's website. Online registration of all of your Sierra products is required for our warranty process. Register now at [www.sierrainstruments.com/register](http://www.sierrainstruments.com/register).

### ***Lifetime Limited Warranty on Patented DrySense Sensor Technology***

In addition to Sierra's standard one (1) year manufacturing warranty on all instruments produced, Sierra also offers a lifetime warranty on all DrySense™ sensors standard with Sierra models 640S, 670S, 780S, 640i, and 780i instruments sold after January 1, 2010. This warranty does not extend to the Model 620S, the BoilerTrak™, the HT (High Temperature) 640S/780S sensor or the 780S UHP (Ultra High Purity) sensors. Learn more about Sierra's warranty policy at [www.sierrainstruments.com/warranty](http://www.sierrainstruments.com/warranty).