

# **Sierra Series 920**

## **Collector-Box™ Insertion Mass Flow Meters**

July 1995

REV. A  
Part Number: IM-92

**SIERRA**  
INSTRUMENTS, INC.

5 Harris Court, Building L · Monterey, CA 93940  
(408) 373-0200 · (800) 866-0200 · Fax (408) 373-4402

SIERRA INSTRUMENTS b.v. · Bolstoen 30A · 1046 AV Amsterdam · The Netherlands  
31(0)20-6145810 · Fax 31(0)20-6145815

**CUSTOMER CAUTION  
RE: OXYGEN SERVICE**

Sierra Instruments, Inc., is not liable for any damage or personal injury, whatsoever, resulting from the use of Sierra Instruments mass flow meters or controllers for oxygen gas. Although Sierra cleans its mass flow meters and controllers prior to shipment, we make no claim or warranty that their cleanliness renders them safe for oxygen service. The customer must clean Sierra Instruments mass flow meters or controllers to the degree required for the customer's oxygen flow applications.

© COPYRIGHT SIERRA INSTRUMENTS 1994

No part of this publication may be copied or distributed, transmitted, transcribed, stored in a retrieval system, or translated into any human or computer language, in any form or by any means, electronic, mechanical, manual, or otherwise, or disclosed to third parties without the express written permission of Sierra Instruments. The information contained in this manual is subject to change without notice.

**TRADEMARKS**

Accu-Flo™, Steel-Trak™, Collector-Box™ and Flo-Box™ are trademarks of Sierra Instruments Inc.

## HOW TO USE THIS MANUAL

Read Section 1, INTRODUCTION. This will give you an overview of the manual and Collector-Box.

Next, proceed to Section 2, INSTALLATION. This provides a detailed description of how to install the Collector-Box, including wiring.

Then read Section 3, FIRST TIME POWER UP AND SYSTEM CONFIGURATION. Read this entire section carefully. You must configure your system properly so that the Collector-Box stores the correct parameters for your system, such as duct area, reference temperature, etc.

Section 4, OPERATING INSTRUCTIONS, should also be reviewed.

The remaining sections of the manual are for Maintenance and Troubleshooting information.



TABLE OF  
CONTENTS

<b>1</b>	<b>Introduction</b> .....	1
1.1	Receipt of Your Collector-Box .....	1
1.2	Product Coverage .....	1
<b>2</b>	<b>Installation</b> .....	2
2.1	Mounting of Collector-Box .....	2
2.2	Access to Field Wiring .....	2
2.3	100/115/230 VAC 50/60 Hz Input Power .....	2
2.4	Signal Wiring .....	2
2.4.1	RS-485 Interface to Flow Meters .....	3
2.4.2	0-5 VDC and 4-20 mA Output .....	3
2.4.3	Auxiliary RS-232/485 Interface .....	4
2.4.4	Relay Outputs .....	4
<b>3</b>	<b>First Time Power Up, System Configuration</b> .....	5
3.1	Power Up .....	5
3.2	Configuration of Your Flow System .....	5
3.2.1	Duct Area .....	6
3.2.2	K-Factor .....	6
3.2.3	Reference Temperature .....	6
3.2.4	Gas Density .....	7
3.2.5	Analog Output .....	7
3.2.6	Digital to Analog Converter Full Scale .....	7
3.2.7	High and Low Flow Alarm Setpoint (Optional) .....	8
3.2.8	Totalizer Alarm Setpoint (Optional) .....	8
3.2.9	Programmable Kickout Flow .....	8
3.2.10	Storing Set up and Checking Network .....	9
3.3	Hidden Configuration Parameters .....	9
3.3.1	Entering Set-up Code and Storing System .....	9
3.4	Diagnostics .....	10
3.5	<F1> Function Key .....	11
3.5.1	Determining the Next Cal Test Time .....	11
3.5.2	Enabling and Configuring or Disabling the Cal Test .....	11
3.5.3	Forcing on Immediate Cal Test .....	12
3.6	<F2> Function Key .....	12
3.6.1	Creating Bias Factors .....	12
3.6.2	Checking the Bias Factors .....	13
<b>4</b>	<b>Normal Operation</b> .....	14
4.1	Flow Display .....	14
4.1.1	How Flow is Computed and Displayed .....	14
4.2	Totalizer .....	15

4.3	Status LEDs .....	15
4.4	0-5 VDC and 4-20 mA Output Signals .....	16
4.5	Alarms .....	16
4.5.1	Displaying Alarm Setpoints .....	17
4.5.2	Relay Outputs .....	17
<b>5</b>	<b>Maintenance .....</b>	<b>18</b>
5.1	Electronics Maintenance .....	18
5.1.1	Access to PCBs .....	18
5.1.2	Fuses .....	19
<b>6</b>	<b>Calibration .....</b>	<b>20</b>
<b>7</b>	<b>Troubleshooting .....</b>	<b>21</b>
7.1	RS-485 Interface Bus to Flow Meters .....	21
7.2	Alarm Relays .....	21
7.3	Customer Service and Shipping Instructions .....	21
<b>Appendix A</b>	<b>.....</b>	<b>22-23</b>

1  
INTRODUCTION

This manual contains information on using the Sierra 920 Series Collector-Box Flow Measuring System. Except where specifically noted, within the text the terms Mass Flow and Flow are used interchangeably.

Caution messages (preceded by **CAUTION!** in the text) appear before procedures which, if not observed, could result in damage to equipment.

Warning messages (preceded by **WARNING!** in the text) indicate that when a specific procedure or practice is not followed correctly, personal injury could result.

Text appearing <**LIKE THIS**> denotes operator buttons on the Collector-Box front panel. This manual contains seven sections plus appendices. Section 1, this section, gives a general introduction. Sections 2, 3, and 4 comprise the main informational sections of the manual for actual use of the Flow Measuring System. Sections 5, 6 and 7 are included for maintenance information and trouble shooting.

Sierra Instruments Applications Engineers may be reached at (408) 373-0200 or (800) 866-0200.

When you receive the Collector-Box, carefully check the outside packing carton for damage incurred in shipment. If the packing carton is damaged, the local carrier should be notified at once regarding their liability. A report should be submitted to Sierra Instruments Customer Service. Remove the packing slip from its envelope and check that the carton contains all parts listed. Make sure spare parts or accessories are not discarded with the packing material. In case of shortages, contact Sierra Instruments Customer Service Department at (408) 373-0200 or (800) 866-0200.

1.1  
Receipt of Your  
Collector-Box

This instruction manual covers the installation and operation of all standard Series 920 Collector-Boxes. They have Model Numbers 92X-(), where X is a decimal digit and () encloses a text description of options. In this manual all standard Series 920 Collector-Boxes will be referred to simply as Collector-Box.

1.2  
Product Coverage

All Collector-Boxes are capable of interconnecting to CEMS Flow Monitors, Accu-Flo and Steel-Trak Insertion Velocity Meters and Mass Flow Meters equipped with the RS-485 interface.

Examples of flow meters that can be connected to a Series 920 Collector-Box:

- 650 CEMS Series flow monitors with "RS" (RS485) Option.
- 600 Series flow meters with "RS" (RS-485) Option.
- 640 Series flow meters with "RS" (RS-485) Option.
- All Standard 650 Series Multi-Point flow meters.

## 2 INSTALLATION

**WARNING!** The Sierra Instruments Collector-Box is not approved by any testing agency for installation in a hazardous location. For applications requiring maximum safety you must use the optional explosion proof enclosure and all wiring must be placed in solid metal conduit.

**WARNING!** All installation procedures must be done with the power off.

For all Collector-Box installations, standard industrial wiring practices apply. Local codes may require the use of conduit. In general, the use of conduit is recommended as good wiring practice.

### 2.1 Mounting of Electronics Enclosures

Mount the Collector-Box in a dry, vibration-free location out of direct sunlight and where the temperature remains within 32-122°F (0-50°C). Place the Collector-Box where the display will be comfortable for viewing.

### 2.2 Access to Field Wiring

Field wiring to the Collector-Box is via terminal barriers.

After opening the enclosure, release the black latch on the front panel by rotating it 90° and swing out the front panel. This will expose the mother board which contains all electronics except the power supply. On the mother board there is a 16-circuit barrier that contains all field wiring including the input for mains power. (Mains power is via a three circuit barrier on the mother board.)

### 2.3 100/115/230 VAC Hz Input Power

**CAUTION!** Be sure that your Collector-Box is equipped for the proper input power by checking the power supply rating on the label.

Mains power is connected to the power supply board located on the bottom of the enclosure below the motherboard. If your Collector-Box was supplied with a power cord, either plug this directly into a wall outlet or remove it and wire directly onto the power terminal barrier, as detailed below.

The three-circuit terminal barrier on the power supply board is marked for AC power wiring. The center screw terminal connects to the chassis. The other two screw terminals are for power input.

Select one of the available entry ports on the Collector-Box for connecting power only, using one or more of the other ports for signal wiring. This will help keep low-level, isolated signals from contacting hazardous AC mains voltages.

Also on the power supply board you will find the circuit protective fuse(s). Refer to Section 5.1.2, MAINTENANCE FUSES, for further information on fuse type, value in amperes, etc.

The load represented by a Collector-Box is about 15 VA maximum.

### 2.4 Signal Wiring

The following sections describe connecting signal wiring to a Collector-Box. Refer to Table 2.4. (Your Collector-Box might not have all the signals listed.)



For all Collector-Boxes, standard industrial wiring practices apply. Local codes may require the use of conduit. In general, the use of conduit is recommended as good wiring practice.

BARRIER #	SIGNAL NAME	DESCRIPTION
1	Aux RS-485 Gnd (3)	Shield for Computer Interface
2	Aux RS-485 [-] (3)	Computer Interface
3	Aux RS-485 [+] (3)	Computer Interface
4	Aux Analog In (2)	Auxiliary Analog Input
5	Aux Analog Gnd (2)	Auxiliary Analog Reference
6	RS-485 Shield (1)	Shield for Flow Meter Interface
7	RS-485 [+] (1)	Flow Meter Interface
8	RS-485 [-] (1)	Flow Meter Interface
9	Aux RS-232 Cntrl Out (3)	Computer Interface
10	Aux RS-232 Cntrl In (3)	Computer Interface
11	Aux RS-232 In (3)	Computer Interface
12	Aux RS-232 Out (3)	Computer Interface
13	Analog Volt Out (1)	0-5 VDC Output (Flow)
14	Analog Ground (1)	Analog Output Reference
15	Analog 4-20 mA Out (1)	4-20 mA Output (Flow)
16	Unused	

Table 2.4  
Signal Wiring

**NOTES:** (1) Signals normally used; (2) Specials only; (3) Auxiliary computer interface (not flow meter wiring)

Included with the Collector-Box is an EIA standard EIA-485 (RS-485) serial bi-directional interface. This interface allows up to 32 flow meters to be daisy chained on a single twisted pair plus shield. Maximum distance is 4,000 feet (1,200 meters) using 24 gauge wire.

### 2.4.1 RS-485 Interface to Flow Meters

The wires for the flow meter RS-485 interface are connected to barrier terminals 7 and 8, with the shield connected to pin 6. Be careful to observe polarity, as shown in Table 2.4, when connecting to pins 7(+) and 8(-).

The Collector-Box is equipped with a 0-5 VDC and a 4-20 mA output signal. This signal usually represents the average of all flow meters connected to the RS-485 bus (Grand Average), but is selectable via <CONF.> to display individual flow meters.

### 2.4.2 0-5 VDC and 4-20 mA Output

The full scale flow value (represented by 5 VDC and 20 mA) is selectable via the <CONF.> set-up procedure described in Section 3.2.5, ANALOG OUTPUT. Normally, it is equal to flow meter full scale multiplied by duct area.

The 0-5 VDC signal can drive a maximum load (minimum resistance) of 1,000 ohms and is output from "Voltage Out" (pin 13) and "Analog Ground" (pin 14). 0-1 and 0-10 VDC outputs are optional.

The 4-20 mA signal can drive up to 10 volts (500 OHMS) including drops in the wire and is output from “4-20 Out” (pin 15) and “Analog Ground” (pin 14).

Whichever analog output signal you use, be sure to use “Analog Ground” (pin 14) for the signal return. **THIS IS NOT A LOOP POWERED DEVICE.**

**2.4.3  
Auxiliary RS-232/48  
Interface**

Future versions of the Collector-Box will include an Optional Computer Interface. It will be front panel selectable for either RS-232 or RS-485 and will output all data collected from the flow meters.

**2.4.4  
Relay Outputs**

The Collector-Box is equipped with four relay outputs which are located on either side of the main terminal barrier on the motherboard. The relay outputs supply dry contacts and provide a Common, Normally Open, and Normally Closed circuit rated at 5A at 125/250 VAC and 0.5A at 24 VDC.

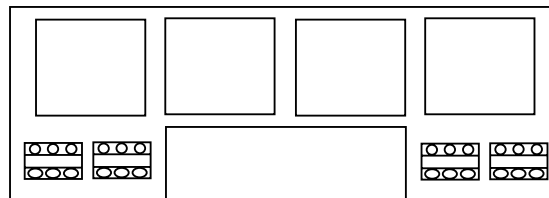

The relays are energized when an alarm condition is active. In addition, the fault, low, and high flow alarm relays are latched. That is, they remain energized until the <ALARM ACKNOW.> button is pressed on the front panel. (NOTE: Relay operation is “interrupted” during Cal Test.) Refer to Section 4, NORMAL OPERATION, for a detailed description of the relay operation.

Table 2.4.3

RELAY	TERMINAL ASSIGNMENTS			RELAY LABEL
	COM	N.O.	N.C.	
Fault	TB3-1	TB3-2	TB3-3	(K1)
Totalizer Alarm	TB3-4	TB3-5	TB3-6	(K2)
Low Flow Alarm	TB4-1	TB4-2	TB4-3	(K3)
High Flow Alarm	TB4-4	TB4-5	TB4-6	(K4)

Relay Terminal Assignments  
(COM=Common, N.O.=Normally Open, N.C.=Normally Closed)

**CAUTION!** Before powering up for the first time, check all wiring, both power and signal.

**CAUTION!** Upon initial application of power, the Flow Measuring System must be configured.

Normally, the minimum wiring that you have already done to form a complete system includes supplying power to the Collector-Box and connecting the RS-485 bus to the flow meters. In many cases this is all the wiring needed. Additionally, you might also have connected one or more of the output signals from the Collector-Box to other equipment (such as a computer).

**NOTE:** If your Collector-Box is part of a CEMS Flow Monitoring System, you only need to plug in the Probe-Boxes, and lastly, the Collector-Box. No programming is required.

Upon application of power the Collector-Box immediately goes into Flow Measuring Mode. The display shows the average flow and a brief summary of system status. The LEDs also reflect system status.

If you connect power only without connecting the RS-485 bus, or if the flow meters connected to the bus are not powered up, the Collector-Box will display zero flow and an RS-485 fault.

The Collector-Box may be turned on or off independently of flow meters, and no damage will result.

**CAUTION!** Every Flow Measuring System must be configured upon initial power up.

It is usually necessary to configure the system only once, or at least only when some major change is made to the system. Once the system is configured, data is stored in non-volatile memory which is retained for an essentially unlimited time. The non-volatile memory does not depend on a back-up power source of any kind, not even a battery.

When the <CONF.> button on the front panel is pushed, you will be shown a sequence of system parameters. As each parameter is shown, you will be asked to accept the previously stored value or to enter a new value. Refer to Section 3.3.1, ENTERING SET UP CODE AND STORING SYSTEM, for access code information.

If you press <YES>, the displayed value is accepted and the screen advances to the next parameter.

If you press <NO>, you will be prompted to enter a new value. Do so by using the numeric keypad. To rub out one or more characters use the <NO> key to backspace the cursor and wipe the previously entered character. When you have entered the desired value correctly press <ENTER>. Again, you will be asked to accept the (new) value. Please note that pressing the <ESC> button will get you out of most situations. Pressing <ESC> when being asked to accept a value will cause the configuration program to abort and not store any of the newly entered values. Pressing <ESC> while being asked to enter a new

## 3 FIRST TIME POWER UP AND SYSTEM CONFIGURATION

### 3.1 Power Up

### 3.2 Configuration of Your Flow System

value will cause the “Try Again...” message to appear on the screen and you will be returned to the previous screen. Therefore, it is important that you go through the entire configuration procedure so that your entered values will be stored.

Also, if you do not take any action, after a period of time the display will “time-out” and you will be returned to normal operation without storing any values.

At the end of the entire sequence of screens all the new values will be stored in non-volatile memory.

The next sections contain step-by-step descriptions of the configuration parameters you will encounter.

### 3.2.1 Duct Area

The first screen you will see after pressing **<CONF.>** will ask you to verify the duct area. Press **<YES>** to accept the displayed value or **<NO>** to enter a new value.

The duct area is the cross sectional area of the duct used to compute mass flow. See Section 4.1, FLOW DISPLAY, for a detailed description of how these flow rates are computed.

While viewing the duct area screen, pressing **<CHANGE UNITS>** will toggle the display between square feet and square meters.

Recommended Value: The cross-sectional area of the duct.

### 3.2.2 K-Factor

The next screen displays the “K-Factor.” Press **<YES>** to accept the displayed value or **<NO>** to enter a new value.

“K-Factor” is a dimensionless quantity used to modify the value of mass flow. It does not affect the velocity value and is included as a “compensation” or “bias” factor to provide flexibility in setting-up a system.

Recommended Value: 1 (no effect)

### 3.2.3 Reference Temperature

The reference temperature is the temperature used to compute gas density and mass flow at a given reference temperature. Its value affects computed mass flow and “Standard” velocity. (Pressure is always referenced to one standard atmosphere). Sierra flow meters are calibrated using a reference temperature of 70°F.

If you select a reference temperature other than 70°F, the Collector-Box performs a conversion to your selected reference temperature based on Charles’ law of ideal gas behavior. The Collector-Box allows you to select a value between 32°F and 100°F (0°C and 37.7°C). To enter a different reference temperature press **<NO>**. To toggle the display between degrees Centigrade and Fahrenheit, press **<CHANGE UNITS>**. If you do change the reference temperature, the gas density (next section) is also adjusted accordingly.

Recommended Value: 70°F. Sierra Instruments calibrates flow meters utilizing a reference temperature of 70°F; however, reference or “Standard” temperature varies by industry and country.

The next screen displays gas density. It is mass per unit volume. By pressing **<CHANGE UNITS>** you may select between pounds per cubic feet (lbs/ft<sup>3</sup>) or grams per liter (gms/l).

### 3.2.4 Gas Density

Gas density is used to compute mass flow. See Section 4.1, FLOW DISPLAY, for a description of the computations performed in arriving at mass flow. To enter a new value, press **<NO>**. To accept a value, press **<YES>**.

Recommended Value: Gas density of application gas at reference temperature. Default is for air: .07486 lbs/ft<sup>3</sup> (1.20023 gms/l) at 70°F.

The Collector-Box outputs one measured flow value simultaneously in 0-5 VDC and a 4-20 mA signal.

### 3.2.5 Analog Output

Normally, this output represents the grand average of all valid points in the system. You may, however, choose to have the analog output represent a single probe (i.e., single flow meter), or even a single point (i.e., single flow measurement sensor or “point”).

To change the measured flow value press **<NO>** or **<FLOW>** and the display will cycle through all individual probes and individual points in the system.

Recommended Value: System Grand Average (average of all valid flow points in the system).

The value of DAC full scale (“DAC FS” on the LCD display) determines the flow value which will be represented by the 5 VDC analog output from the Collector-Box. It is normally the grand average of all flow meters in the system. By pressing **<CHANGE UNITS>** the value is cycled through all available flow units: SCFM, SCFH, SM3H, SFPM, SMPS, LB/H, LB/M, and KG/H.

### 3.2.6 Digital to Analog Converter Full Scale

The advantage of being able to program DAC FS is to “tweak” the full scale to exactly the value you want, which can be done in the field, and even if the desired value is finally determined after the system has been ordered, built, and installed.

For instance, assume that the originally specified full scale of the system (and consequently of the flow meters) is 43,000 SCFM. Setting the DAC full scale to 43,000 SCFM will result in a maximum output signal of 5 VDC at 43,000 SCFM.

If after installation, it is determined that 40,000 SCFM would be a better value, (perhaps this is what the process computer being fed from the Collector-Box analog output signal expects) simply change the DAC FS to 40,000 SCFM and the Collector-Box will output 5.000 VDC at 40,000 SCFM.

The Collector-Box DAC full scale can be set to any desired value. However, it is unlikely that it will be useful to set it to a value very different from that of the flow meters, which cannot be changed. Setting it to a value greater than the flow meter full scale will result in the output never reaching 5 VDC. Setting it to a value less than the flow meter full scale results in a loss of resolution.

Recommended Value: 100% of the flow meter full scale which is full scale flow and duct area. The full scale velocity and the duct area are programmed into the Collector-Box. The duct area is available by using the instructions into Section 3.2.1, DUCT AREA. The programmed full scale velocity is available by hitting \*9 and advancing the displayed values until the full scale velocity is displayed. (Flow meter full scale is usually set to 30% greater than the specified maximum system flow).

### 3.2.7 High and Low Flow Alarm Setpoint (Optional)

If your Collector-Box has alarms you can adjust the high and low alarms in the same way. To accept the displayed value press **<YES>**; to enter a new value press **<NO>**.

By pressing **<CHANGE UNITS>** the value is converted between all available flow units: SCFM, SCFH, SM3H, SFPM, SMPS, LB/H, LB/M, and KG/H.

Recommended Value: Zero to flow meter full scale.

### 3.2.8 Totalizer Alarm Setpoint (Optional)

If your Collector-Box has a totalizer alarm the setpoint (count up) or preset (count down) will now be displayed.

The alarm setpoint is the value at which the totalizer alarm is activated. (See Section 4.2, TOTALIZER.) To accept the displayed value press **<YES>**, to enter a new value press **<NO>**.

The displayed value is shown in scientific notation. However, you can enter a new value in fixed point (i.e., just enter the desired value). The entered value will be shown in scientific notation and rounded to three decimal places. Internally, the value is stored in as accurate a form as possible (about .05% accuracy).

By pressing **<CHANGE UNITS>** the value is converted between all available flow units: FT3, M3, LBS, and KG.

Recommended Value: Zero to 1 E+09 FT3 (2.831 E+07 M3)

### 3.2.9 Programmable Kickout Flow

Sierra Instruments flow meters with RS-485 capability monitor their flow measuring circuitry for hardware faults. In the event of a detected hardware problem, the Collector-Box illuminates the sensor fault LED and activates the fault alarm.

Additionally, the Collector-Box may be programmed with a high and low flow “Kickout” value for the system. What these two values represent is a “window” which defines a “good” velocity reading. If the flow value goes outside the

window, the fault alarm is activated. The kickout window differs from the normal hardware monitoring of the flow measuring circuitry in that it can fault a flow point even though the hardware is functioning.

Its main advantage is to detect problems relating to maintenance such as plugging of sensors rather than electronic failure. Its main disadvantage is that you run the risk of nuisance alarms.

Recommended Value: Do not use the kickout feature unless you are sure you will benefit from it. Try to set the window as wide as possible taking into account the normal worst case flow variations in your system.

At the end of the configuration process, the Collector-Box stores all the configuration parameters into non-volatile memory and then checks the flow network by querying every address on the RS-485 bus.

**3.2.10  
Storing Set up and  
Checking Network**

When the Collector-Box reports the number of flow meters in the system, it must match the numbers that are physically present. Here are the screens you will see and a brief description of what the Collector-Box is doing:

SCREEN	DESCRIPTION
Storing Set-up Please Wait...	All configuration parameters are being stored
Checking Network Please Wait...	Every address (1-32) is being queried
D Flow Meters	Number of flow meters found D is an integer between 1 and 32
Set-up Complete	Final message before return to normal operation

**CAUTION!** Accessing hidden configuration parameters causes a re-count of the number of flow meters which define the system configuration. Be sure all flow meters are connected to the RS-485 bus and powered-up and that at the end of the configuration procedure (Section 3.2, CONFIGURATION OF YOUR FLOW SYSTEM), the same number of flow meters are shown on the display as are physically in the system.

**3.3  
Hidden Configuration  
Parameters**

It is normally unnecessary to access the hidden parameters. The only hidden parameter currently supported is the number of flow meters in the system. This is entered at the factory. It is only necessary to change this value if the number of flow meters in the system has changed, either by addition or deletion.

To access the hidden parameters press <CONF.>, enter the “master” access code, 93924, and step through the Field Configuration procedure above. At the end of this procedure, while the screen displays “Checking Network Please Wait...,” press and hold <\*> on the front panel. The addresses of all active flow meters which are on-line are now stored in non-volatile memory.

**3.3.1  
Entering Set Up Code  
and Storing System**



The reason for storing the system configuration is so that the Collector-Box will recognize which of the available addresses (1-32) are being used by your system. When a flow meter is off-line the Collector-Box will be able to detect this condition and indicate a system fault.

You may enter your own personal access code by pressing **<CONF>**, entering 93924, and pressing **<ENTER>**. While the screen displays “access accepted”, press **<\*>** and you will be prompted to enter your own access code.

**NOTE:** the “master” access code of 93924 is always active.

### 3.4 Diagnostics

Pressing the **<DIAG.>** button on the front panel causes the Collector-Box to run a diagnostic self-check of itself and to check that all flow meters are present on the RS-485 bus.

After pressing **<DIAG.>**, you will see the message: “SIERRA Collector-Box” moving across the screen.

Then a series of self-check screens will appear. The first screen gives the version of the software. The second tests the LEDs. Then the keypad is tested.

Next, you will be asked if tests should be made which affect outputs. Press **<YES>** or **<NO>**. If you answer **<YES>**, the Analog Output (0-5 VDC and 4-20 mA) is ramped up and down in a sawtooth waveform between zero and full scale for a brief period of time. Then if you have chosen **<YES>**, the relays are energized and then de-energized.

**CAUTION:** Choosing **<YES>** is not recommended if the Collector-Box is connected to a system that would be adversely affected by this waveform event.

Following this, a number of internal checks are performed.

Finally, the network is inspected. If no faults in the Flow Measuring System are detected the display will indicate this. If faults are detected each fault is shown on the display. If there is more than one fault, each one is sequentially displayed.

For instance, if the flow meter at address 1 does not respond the display will indicate: “Probe Box 1, RS-485 Fail.”

If the flow meter at address 3 responds but has a bad sensor number 4, the display will indicate: “Probe Box 3, Sensor Fault 4.”

If both of the above conditions exist at the same time, then the first message is shown for a few seconds, then the other message is shown.

If you have kickout programmed ON, then any sensors reading outside of the programmed kickout “window” will also be shown.

After the flow meters are checked, the Collector-Box automatically returns to normal operation.



If you enabled Cal Test when configuring the Sierra system, you can press **<F1>** to:

3.5  
**<F1> Function Key**

- display the number of hours until the next calibration test occurs
- force an immediate calibration test

If you want to determine when the next calibration test will occur, press and hold down **<F1>**. As long as you press the key (and don't let the countdown timer reach 0), the display will indicate the number of hours until the next test begins.

3.5.1  
**Determining the Next Cal Test Time**

**NOTE:** The calibration test will occur every twenty-four hours at the time you set here.

If you want to enable and configure or disable the calibration test:

3.5.2  
**Enabling and Configuring or Disabling the Cal Test**

- 1 Press **<CONF.>** and enter your access code. (See Section 3.3.1, ENTERING SET UP CVOICE AND STORING SYSTEM, for access code information.)
- 2 When Cal Test Y/N appears on the display, respond by pressing **<YES>** if you want to enable the calibration test, or **<NO>** if you want to disable the test.
- 3a If you enable the calibration test, the system will respond with Time to Test Y/N 23.xx. If a starting time of the current time plus 23.xx is acceptable, press **<YES>**. If you want to change the starting time, press **<NO>** and enter the new start time, in hours from the current time.
- 3b You will be prompted again with Time to Test Y/N (your new time). If you want to accept the new time, press **<YES>**. If you want to change the time again, press **<NO>** and repeat step 3a.
- 4a The system will now prompt you with Test Duration Y/N 10 seconds. (This indicates that the system will first generate a ten second zero-scale output and then generate a ten second full-scale output.) If you want to accept the default ten second test, press **<YES>**. If you want to change the duration of the test, press **NO**. Each time you press **NO**, you will increment the length of the test by ten seconds—to a maximum of 210 seconds. (If you continue to press **<NO>** after the display indicates 210 seconds, the system will repeat the ten second test duration.)
- 4b When the display indicates an acceptable test duration, press **<YES>**.

**NOTE:** Pressing **<ENTER>** accepts all of the remaining parameters.

### 3.5.3 Forcing an Immediate Cal Test

If you want to force an immediate calibration test, press and hold down **<F1>**. A countdown timer will begin counting from 10 to 0. When the timer reaches 0, release **<F1>** and a calibration test will begin.

**CAUTION!** The Cal Test consists of a zero output condition with simultaneous activation of the low alarm for the chosen test duration. Immediately following this, a full scale test, consisting of a full scale output condition concurrent with deactivation of the low alarm and activation of the high alarm for the chosen test duration is run. Finally, all “normal” control is returned.

**NOTE:** The duration of the calibration test is determined by the test duration stored in the memory of the Collector-Box.

### 3.6 <F2> Function Key

If your Sierra system is being evaluated and compared to a standard calibration device such as an S-type Pitot tube and if the flow curve of the Sierra system differs from that of the calibration standard, you can use the Collector-Box’s K-factor to make simple span adjustments to the flow curve of the Sierra system (see Section 3.2.2, K-FACTOR). Alternatively, you can use the **<F2>** function to establish between 2 and 20 bias factors to fine-tune the Sierra system so that its flow curve matches the calibration standard.

**NOTE:** In order to establish correct bias factors, you must conduct a RATA (Relative Accuracy Test Audit) first. You will use the data from the RATA to create bias factors as described in the following procedure.

#### 3.6.1 Creating Bias Factors

To add bias factors to the configuration data stored in the memory of the Collector-Box:

- 1 Press **<F2>** twice. You will be prompted for your access code. (This is the same access code you use when configuring the system.)
- 2 Type in your access code and press **<ENTER>**.
- 3 When you are prompted with Bias Y/N, press **<ENTER>**.
- 4 When you are prompted whether you want to use previous Bias, press **<NO>**.
- 5 The system then asks how many factors you want to use. You can enter any number between 2 and 20. Increment the number of factors by pressing **<YES>**; decrement the number of factors by pressing **<NO>**.
- 6 When you are prompted for Ref Val 1, type the first reference value and press **<ENTER>**.
- 7 When you are prompted for Sierra No 1, type the first Sierra value and press **<ENTER>**.
- 8 Repeat steps 6 and 7 to add as many bias factors as you want to include in the system configuration.

**NOTE:** If you make a mistake when typing a value, press <NO> to backspace over the incorrect number.

You can check the reference and Sierra values after you have entered and saved the data in the memory of the Collector-Box. First, press <F2> once. Then press <YES> to see the first reference method value (RM1) and associated Sierra value (SI1). Continue to press <YES> to see subsequent combinations of reference method and Sierra values.

**NOTE:** The first set of values (RM0 and SI0) will always indicate 0.

If you notice an error in any of the values, press <F2>. The system will then put you at the beginning of the procedure for creating new bias factors (see Section 3.6.1, CREATING BIAS FACTORS).

**3.6.2  
Checking the  
Bias Factors**

### 4 NORMAL OPERATION

**CAUTION!** Upon initial application of power, the Flow Measuring System must be configured. See Section 3, FIRST TIME POWER UP AND SYSTEM CONFIGURATION.

When powered-up, the Collector-Box goes into normal operation. In this state the display shows the flow rate in the engineering units that were in effect the last time the system was configured.

In the following sections, a detailed description of Collector-Box operation is given.

#### 4.1 Flow Display

Upon power up, or by pressing the <FLOW> button on the front panel, the average flow is displayed on the display.

By pressing <CHANGE UNITS> the units of flow measurement are cycled SCFM, SCFH, SM3H, SFPM, SMPS, LB/M, LB/H, and KG/H. (See Table 4.1).

Also displayed is a brief description of system status such as “System OK” or “System Fault.” The LEDs work in conjunction with the display to alert you to any problems or alarms.

The Collector-Box inspects the status of each point before it uses it to calculate the average. If any errors are detected, that point is not used in the calculation and a fault is flagged. Only valid points are included in the average. This inspection occurs 20 times/second.

The average flow is based on all valid points in the system. By repeatedly pressing the <FLOW> button the average is based on single probes or even on individual points. When a subset of all possible flow measuring points is used to calculate the average, this is shown on the display. For example, when displaying the average flow based on all points in the system, and assuming no faults are detected, you would see: “AVG dddd.dd SCFM, System OK”; where d is a decimal digit between 0 and 9.

After pressing <FLOW> you would see: “PROBE 1 Average, dddd.dd SCFM.” Pressing <FLOW> again would result in the following display: “Probe1 Point1, dddd.dd SCFM.”

In each case, the flow for the entire duct is being computed. In the first case all points in the system are being used. In the second case all the points on a single probe are being used. In the last case a single point on a single probe is being used. By looking at individual probes and points you can better evaluate the flow profile in the duct.

##### 4.1.1 How Flow is Computed and Displayed

There are three types of flow and eight different engineering units that may be displayed via the <CHANGE UNITS> front panel button. The following describes each one and how it is calculated.

- Velocity – The standard display is obtained by averaging all valid points in the system. The available engineering units are SFPM (Standard Feet Per Minute) and SMPS (Standard Meters Per Second).  $(\text{Velocity}) = (\text{Sum of all valid points}) / (\text{Number of valid points})$ .

- Mass Flow – Multiplying velocity by the duct area yields mass flow. Additionally, this mass flow is multiplied by a field-selectable K-factor. The K-factor can be set to 1.000 (no effect) or to some other value to correct for system anomalies.

Available engineering units are SCFM (Standard Cubic Feet per Minute), SCFH (Standard Cubic Feet per Hour), and SM3H (Standard Meters Cubed per Hour). That is:  $(\text{Mass Flow}) = (\text{Velocity}) * (\text{Duct Area}) * (\text{K-Factor})$ .

- The mass flow can be further multiplied by the gas density to arrive at “true” mass flow. Available units for mass flow are LB/M (Pounds per Minute), LB/H (Pounds per Hour), and KG/H (Kilograms per Hour).  $(\text{Mass Flow}) = (\text{Flow}) * (\text{Gas Density})$ .

TYPE OF FLOW	UNITS (<FLOW> BUTTON)
Velocity	SFPM, SMPS
Mass Flow	SCFM, SCFH, SM3H
Mass	LB/M, LB/H, KG/H

Table 4.1  
Flow Readout  
Options

Pressing the <TOTAL> pushbutton on the front panel causes the display to read accumulated mass and elapsed time in the following format: TO 1.234E+07 FT3, 12.345 Hours; where the total mass is displayed in scientific notation.

## 4.2 Totalizer (Optional)

“Overflow” occurs at 1.000 E+10 FT3. When the alarm value is reached or exceeded, the totalizer alarm is activated.

The totalizer is backed-up into non-volatile EPROM every ten minutes. This back-up preserves the totalized readings despite power interruptions and has an essentially unlimited storage time.

To reset the totalizer, press <\*> on the front panel. Then press <TOTAL>. You will see the Reset Countdown on the display. By pressing <TOTAL> until the countdown reaches zero, the totalizer is reset to zero.

See Section 3.2.8, TOTALIZER ALARM SETPOINT, for setting the totalizer alarm.

The front panel status LEDs include Power, Sensor Fault, RS-485 Fault, High Alarm, Low Alarm, and Totalizer Alarm.

## 4.3 Status LEDs

- Power – This LED is illuminated when power is applied to the Collector-Box and the microprocessor is functioning.
- Sensor Fault – This LED is illuminated when a problem is detected by one or more flow meters in their precision flow measuring circuits. The Collector-Box does not include the flow indication of these sensor faulted circuits in calculating the average mass flow.

- RS-485 Fault – This LED is illuminated when one or more flow meters are not responding as expected on the RS-485 interface bus.
- High and Low Alarms (Optional) – These LEDs are illuminated when the measured flow is above/below the preset alarm setpoints, respectively. There is a built-in delay between detection of a Flow Alarm and activation of the LED. Refer to Section 4.5, ALARMS.
- Totalizer Alarm (Optional) – This LED is illuminated when the total mass flow has exceeded the alarm value. Refer to Section 4.5, ALARMS.

### 4.4 0-5 VDC and 4-20 mA Output Signals

The Collector-Box is equipped with a 0-5 VDC and a 4-20 mA output signal. This signal represents the average flow. The full scale value for this signal is programmable via the configuration procedure. Refer to Section 3.2, CONFIGURATION OF YOUR FLOW SYSTEM.

The Collector-Box has a **<FAST SLOW>** button that determines the speed of response of the grand average flow. By pressing and holding **<FAST SLOW>**, you can select how many readings are used to compute the grand average. The method used is commonly referred to as a “box car” filter. Normally when pressing **<FAST SLOW>**, an arrow indicates where the response speed is relative to the fastest and slowest setting. When at the fastest or slowest setting, the display shows a rectangular box so that you can more easily set the response.

### 4.5 Alarms

There are four alarms on the Collector-Box: Fault, Low Flow, High Flow, and Totalizer.

Refer to Section 2.4.4, RELAY OUTPUTS, for a description of where the relay terminals are located and how to wire to them.

Alarm logic is the same for all alarms. An alarm condition must be continuously present for a period of time before the corresponding alarm is activated. The alarm lights the front panel LED and activates the relay.

The alarm stays in effect regardless of whether the alarm condition persists until the front panel button **<ALARM ACKNOW.>** is pressed. If the alarm condition is no longer present, then **<ALARM ACKNOW.>** turns off both the LED and relay. If the alarm condition is still present, then the relay is turned off and the LED continues to glow. If the alarm condition then disappears, the LED is extinguished.

The Fault Alarm is supplied as a standard with every Collector-Box. It is activated whenever a fault condition is detected in the flow measurement system. This could be a Sensor Fault, RS-485 Fault, or Kickout (Kickout is when the flow is outside of a window; see Section 3.2.9, PROGRAMMABLE KICKOUT FLOW). Also, if the LCD is in a display mode that shows system status, a fault message will appear on the display.

The other alarms are all optional. The high and low flow alarms are activated when the grand average flow rate is above or below the alarm setpoints, respectively. The totalizer alarm is activated when the totalized mass is above the alarm setpoint.

All alarms except totalizer must be continuously active for a period of time before the relay and LED are activated. This time delay is meant to reduce nuisance alarms.

**CAUTION!** Refer to Section 3.4, DIAGNOSTICS and 3.5.3, FORCING ON IMMEDIATE CAL TEST, for cautions on alarm states during the Relay Test and Cal Tests, respectively.

By pressing **<ALARM>**, the low flow, high flow, and totalizer alarms are displayed (if installed). The **<ALARM>** button displays the alarms only.

In order to adjust the alarm setpoints you must go through the configuration menu. This is achieved by pressing **<CONF.>** on the front panel and stepping through the configuration procedure until you are prompted for setpoints. See Section 3.2, CONFIGURATION OF YOUR FLOW SYSTEM.

The relay output marked “FAULT” is activated when there is a trouble condition. A trouble condition is either an RS-485 fault or sensor fault. Assuming that the display is showing system status, whenever a fault is detected the display reflects this immediately. If the fault persists for a short period of time, then the relay and fault LED are activated.

There are three optional relay outputs: Low Flow, High Flow, and Totalizer.

See above Section 4.5, ALARMS, for a detailed description of the alarm logic. See Section 2.4.4, RELAY OUTPUTS, for a description of where the relay terminals are located and how to wire to them.

### 4.5.1 Displaying Alarm Setpoints

### 4.5.2 Relay Outputs

## 5 MAINTENANCE

**CAUTION!** Changing the output signal from the Collector-Box, such as by adjustment of potentiometers or turning power off, may affect other plant equipment, alarm outputs, etc.

Refer to Section 7, TROUBLESHOOTING, if you need to return your 920 Collector-Box to Sierra Instruments for repair.

### 5.1 Electronics Maintenance

**WARNING!** Before gaining access to PCBs (printed circuit boards), turn power off.

#### 5.1.1 Access to PCBs

Access to the PCBs is a simple matter in the Collector-Box.

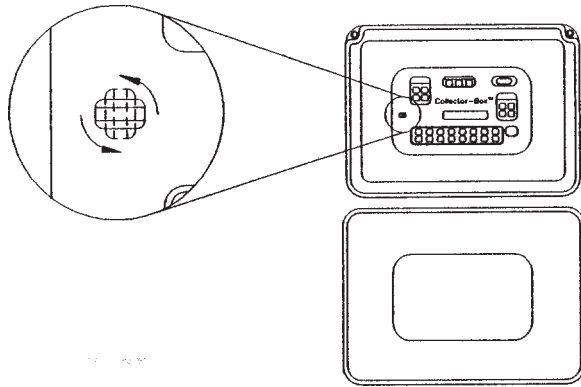

First locate the black plastic latch on the left side of the front panel near the status LEDs. By turning the slot in the latch to a vertical position the latch is released.

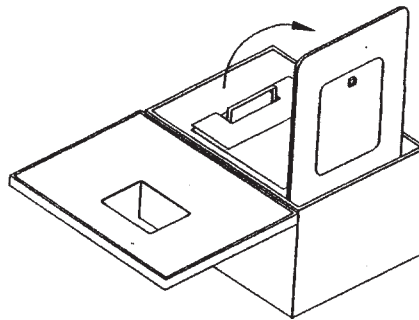

Release the latch and swing out the front panel. This exposes the motherboard which contains all adjustment potentiometers, wiring barriers including those for mains power, and alarm relays.



5.1.2  
Fuses

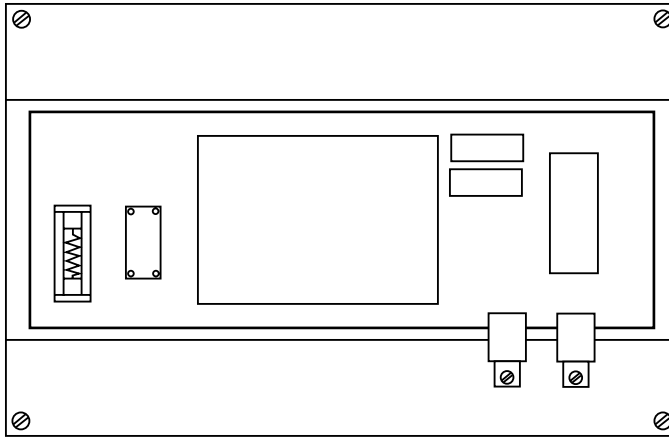

On the bottom of the enclosure is the power supply board containing the fuses.

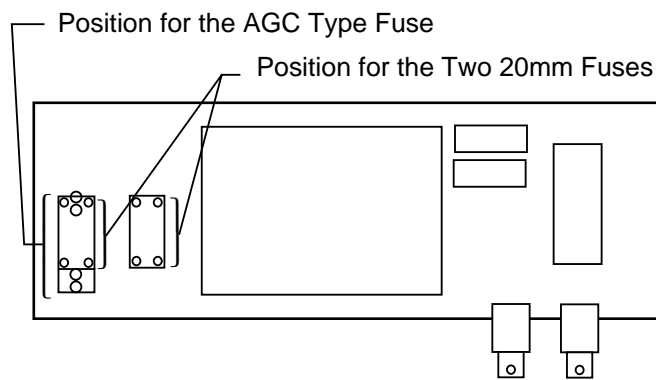

On the power supply board (located on the bottom of the enclosure), you will find one AGC type fuse for 115 VAC power and two 5 mm by 20 mm fuses for 230 VAC power.

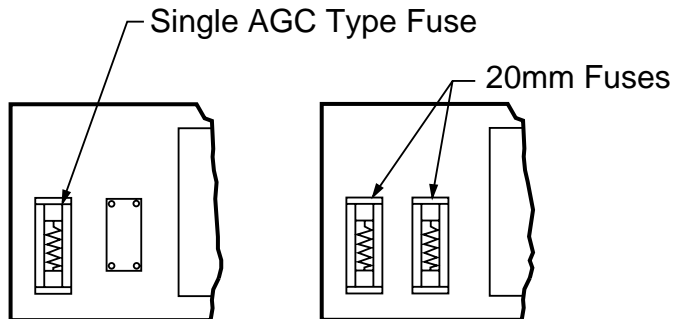

115 VAC units have a single AGC type fuse with a value of 1 Ampere, while 230 VAC units have fuse ratings of .50 Amperes.

### 6 CALIBRATION

The only calibration adjustment required on the Collector-Box is to set the full scale for the voltage out. This is a very low drift precision circuit which normally does not need maintenance. To check the 0-5 VDC and 4-20 mA outputs, press <\*> and then <4> on the front panel. As shown on the display, the Collector-Box first outputs zero and then full scale to both the voltage and current outputs.

By adjusting potentiometer R39 on the motherboard you can adjust the voltage output to its exact rated value.

If you experience any problem with your Series 920 Collector-Box, the solution is usually simple. This section helps you find that simple solution. If you cannot solve the problem yourself, please call Sierra's Customer Service Department, at (800) 866-0200.

**7**  
**TROUBLE-**  
**SHOOTING**

When you press <**DIAG.**>, the Collector-Box runs through a brief self test of its electronics and then checks the flow meters which are supposed to be on-line. If no faults are detected in the entire system, this condition is noted on the display. Pressing any button causes normal operation to be resumed.

**7.1**  
**RS-485 Interface**  
**Bus to Flow Meters**

If a flow meter is not responding, RS-485 Fault is indicated on the display and the LED is illuminated. When this occurs, press <**CONF.**> and run through the sequence until the end. The number of flow meters in the network will then be displayed.

If the number of flow meters appears as zero, the most likely problem is with the RS-485 cable. Check cable integrity throughout its entire length and verify that polarization has been observed on barrier strips. Using cable with a third shield wire might help correct the problem.

If a fault is detected by a probe in one or more of its precision flow measuring circuits, sensor fault is indicated on the display and the LED is illuminated. This could indicate a broken sensor. The probe for that flow meter should be physically inspected.

The alarm relays are mounted on a PCB located on the motherboard and surrounding the main terminal barrier. The entire relay PCB can be replaced in the field as a single unit. Refer to Section 7.3, CUSTOMER SERVICE AND SHIPPING INSTRUCTIONS, to order a replacement relay board.

**7.2**  
**Alarm Relays**

The Sierra Instruments Customer Service Department can be reached at (408) 373-0200 or (800) 866-0200. Please have your model number and serial number available when you call.

**7.3**  
**Customer Service and**  
**Shipping Instructions**

If you find it necessary to return a Series 920 Collector-Box to Sierra Instruments, you must first obtain a Return Material Authorization from the Customer Service Department. **Please include information describing the reason for the return, purchase order number under which the equipment was purchased, and phone number.**

Ship all Series 920 Collector-Boxes to the following address: Sierra Instruments, Inc., 5 Harris Court, Building L, Monterey, California 93940. **Be sure to include complete return shipping instructions. We cannot deliver to post office boxes.**

### APPENDIX A RS-485 Flow Meter Interface Bus

The following description of the Sierra RS-485 protocol is provided mainly for reference, although if you want, you can write your own software driver for a RS-485 equipped computer.

The RS-485 interface is a hardware standard only. Sierra Instruments has implemented a software protocol in order to use the interface specifically for its own Flow Measuring Systems. According to this scheme there is one “master” transceiver (Collector-Box or PC compatible computer) and up to 30 “slave” transceivers (flow meters). The data format is 11 bits: 1 start bit, 8 data bits (MSB first), a tenth programmable bit (not parity), and a stop bit. The data rate is 9600 baud.

Remember, the RS-485 interface is bi-directional, so you must control the transmission direction of the “master” (the computer for which you are writing software). Slaves (flow meters) are always receiving, unless specifically addressed by the master.

To initiate a data exchange the master transmits an address (130) with the tenth bit equal to 1. At all other times the tenth bit is zero. This causes all flow meters to be interrupted. They then inspect the received address to see if it matches their own address. If it doesn't, no action is taken and normal processing is resumed. If a match is detected, then the flow meter responds with a transmission which occurs within about the next 100 milliseconds. Refer to the table below for a complete description of all bytes transmitted from the addressed “slave” (flow meter).

BYTE NO.	DESCRIPTION
1	Flow Meter Address Echo Value: 1-30
2	Flow Meter Type Value: 1=Single Point, 2=Multi Point
3, 4	Flow Meter Software Version Value: 0-65,535 100=Version 1.00, 250=Version 2.50, etc.
5	Number of Points Value: 1=1 point, 2=2 points, etc.
6	Units English/Metric Value: 0=MPS/°C, 1=SFPM/°F
7, 8	Full-scale Value Value: 0-65,535=0-65,535 MPS or SFPM depending on units above
9, 10	Low Alarm Setpoint Local (Flow Meter Only) Low Alarm Value: 0-65,535
11, 12	High Alarm Setpoint Local (Flow Meter Only) High Alarm Value: 0-65,535
13	Flow Meter Supply Voltage Value: 0-255=0 to 25.5 volts
14	Speed of Response. Proportional to response speed of signal from flow meter. Value: 1-255 (1=fast, 255=slow)

15, 16	Alarm Status Flags Value: Alarms ON/OFF flags 1=alarm, 0=no alarm LSB b1=hi alm b0=lo alm
17, 18	Fault Status Flags Value: Faults ON/OFF flags 1=Fault, 0=No Fault MSB represents self check function, 1=fault, 0=ok b1=ram b0=a/d LSB represents bridge check, 1=fault, 0=ok b7=bridge 8,...,b0=bridge1 LSB represents points 1 through 8 any bits not listed are always set to 0
19, 20	Temperature Value Value: 0-65,535
21, 22	Average Flow Value Value: 0-65,535
23-38	Individual Point Flow Value Point 1-8, each reading Value: 0-65,535 Unused points Value: 0
39-48	Spare All bytes Value: 0
49, 50	Checksum Binary sum of all transmitted bytes including address, modulo 16 bits Value: 0-65,635

Rev 1.02 SierraNet Protocol

**NOTE:** All numbers transmitted represent unsigned binary numbers unless noted. For two byte numbers, transmission is MSB first then LSB. Refer to Sierra Instruments Applications Engineering at (800) 866-0200 for the latest release version.



