

**Sierra Series 670  
Digital Flow  
Averaging Array**  
Including the 920 Collector-Box™

March 1996

REV. B  
Part Number: IM-67-CEMS

**SIERRA**  
INSTRUMENTS, INC.

5 Harris Court, Building L · Monterey, CA 93940  
(408) 373-0200 · (800) 866-0200 · Fax (408) 373-4402

SIERRA INSTRUMENTS b.v. · Bolstoen 30A · 1046 AV Amsterdam · The Netherlands  
31(0)20-6145810 · Fax 31(0)20-6145815

© COPYRIGHT SIERRA INSTRUMENTS 1994

No part of this publication may be copied or distributed, transmitted, transcribed, stored in a retrieval system, or translated into any human or computer language, in any form or by any means, electronic, mechanical, manual, or otherwise, or disclosed to third parties without the express written permission of Sierra Instruments. The information contained in this manual is subject to change without notice.

## **TRADEMARKS**

Collector-Box™, Probe-Box™, Digi-Bridge™, Auto-Self Clean™, Steel-Trak™, and FR™ (sensors) are trademarks of Sierra Instruments, Incorporated.

## **RECEIPT OF YOUR FLOW AVERAGING ARRAY**

When you receive your Series 670 Digital Flow Averaging Array, carefully check the outside packing carton for damage incurred during shipment. If the packing carton is damaged, you should notify the local carrier at once regarding their liability. You should also submit a report to Sierra Instruments Customer Service at the address or phone shown below.

Remove the packing slip from its envelope and check that the carton contains all parts listed. Make sure you do not discard any spare parts or accessories with the packing material. If there are shortages in the shipment, inform Sierra Instruments Customer Service at the address or phone shown below.

**Sierra Instruments Customer Service**  
**5 Harris Court, Building L**  
**Monterey, CA 93940**  
**(408) 373-0200 (Phone)**  
**(800) 866-0200 (Phone)**  
**(408) 373-4402 (Fax)**

## **CUSTOMER CAUTION**

### **RE: OXYGEN SERVICE**

Sierra Instruments, Inc. is not liable for any damage or personal injury, whatsoever, resulting from the use of Sierra Instruments mass flow meters or controllers for oxygen gas. Although Sierra does clean its mass flow meters and controllers prior to shipment, we make no claim or warranty that their cleanliness renders them safe for oxygen service. The customer must clean Sierra Instruments mass flow meters or controllers to the degree that they require for their oxygen flow applications.



<b>1</b>	<b>Overview</b> . . . . .	<b>1</b>
	1.1 About the Operators Manual . . . . .	1
<b>2</b>	<b>Principles Of Operation</b> . . . . .	<b>3</b>
<b>3</b>	<b>Installation</b> . . . . .	<b>5</b>
	3.1 Mounting of Probes and Probe-Boxes . . . . .	5
	3.2 Access to Field Wiring . . . . .	7
	3.3 Power Supply Wiring . . . . .	11
	3.3.1 100/115/230 VAC 50/60 Hz Input Power . . . . .	11
	3.3.2 24 VDC Input Power . . . . .	12
	3.4 Remote Probe Wiring (350 feet maximum) . . . . .	13
	3.5 Signal Wiring . . . . .	13
	3.5.1 0-5 VDC and 4-20mA Outputs . . . . .	14
	3.5.2 RS-485 Interface . . . . .	14
<b>4</b>	<b>Operating Instructions</b> . . . . .	<b>17</b>
	4.1 General Description . . . . .	17
	4.2 Probe-Box Motherboard LEDs . . . . .	17
	4.3 Controller Board LEDs . . . . .	17
	4.4 Calibration Voltage Output Switch, SW1 . . . . .	18
	4.5 Output Select Jumper (JB4) . . . . .	18
	4.6 Digi-Bridge Board Outputs . . . . .	18
<b>5</b>	<b>Monitoring Total Flow Rate</b> . . . . .	<b>19</b>
	5.1 Stack and Flue Monitoring . . . . .	21
<b>6</b>	<b>Calculating Actual Flow Rate</b> . . . . .	<b>23</b>
<b>7</b>	<b>System Maintenance</b> . . . . .	<b>25</b>

7.1	Access to Electronics PCAs . . . . .	25
7.2	Totalizer Back-up Battery . . . . .	25
7.3	Probe Cleaning . . . . .	25
7.4	Probe Breakage or Damage . . . . .	25
7.5	Replacing Sensors . . . . .	26
7.5.1	Required Tools and Supplies . . . . .	26
7.5.2	Sensor Replacement Procedure . . . . .	26
<b>8</b>	<b>Collector-Box Installation . . . . .</b>	<b>31</b>
8.1	Mounting the Collector-Box . . . . .	31
8.2	Access to Field Wiring . . . . .	31
8.3	100/115/230 VAC Input Power . . . . .	31
8.4	Signal Wiring . . . . .	32
8.4.1	RS-485 Interface to Probe-Boxes . . . . .	33
8.4.2	0-5 VDC and 4-20mA Output . . . . .	34
8.4.3	Relay Outputs . . . . .	34
<b>9</b>	<b>System Configuration . . . . .</b>	<b>37</b>
9.1	Powering Up the Collector-Box . . . . .	37
9.2	Configuring the System . . . . .	37
9.2.1	Duct Area . . . . .	38
9.2.2	K-factor . . . . .	38
9.2.3	Reference Temperature . . . . .	39
9.2.4	Gas Density . . . . .	39
9.2.5	Analog Outputs . . . . .	39
9.2.6	Digital to Analog Converter Full Scale . . . . .	40
9.2.7	High/Low Flow Alarm Setpoints (Optional) . . . . .	40
9.2.8	Totalizer Alarm Setpoint (Optional) . . . . .	41

9.2.9	Programmable Kickout Flow . . . . .	41
9.2.10	Storing Setup and Checking Network . . . . .	42
9.3	Hidden Configuration Parameters . . . . .	42
9.3.1	Entering Setup Code and Storing System Configuration . . . . .	42
9.4	Diagnostics . . . . .	43
9.5	F1 Function Key . . . . .	44
9.6	F2 Function Key . . . . .	44
9.6.1	Creating Bias Factors . . . . .	44
9.6.2	Checking the Bias Factors . . . . .	45
9.7	F3 Function Key . . . . .	45
9.8	F4 Function Key . . . . .	46
<b>10</b>	<b>Normal Operation . . . . .</b>	<b>47</b>
10.1	Flow Display . . . . .	47
10.1.1	How Flow is Computed and Displayed . . . . .	48
10.2	Totalizer (Optional) . . . . .	49
10.3	Status LEDs . . . . .	49
10.4	0-5 VDC and 4-20mA Output Signals . . . . .	50
10.5	System Alarms . . . . .	50
10.6	Displaying Alarm Setpoints . . . . .	51
10.7	Relay Outputs . . . . .	51
<b>11</b>	<b>Collector-Box Maintenance . . . . .</b>	<b>53</b>
11.1	Access to PCAs . . . . .	53
<b>12</b>	<b>Calibration . . . . .</b>	<b>55</b>
<b>13</b>	<b>Troubleshooting . . . . .</b>	<b>57</b>
<b>14</b>	<b>Sierra Repair . . . . .</b>	<b>59</b>
<b>A</b>	<b>Specifications . . . . .</b>	<b>61</b>

<b>B</b>	<b>RS-485 Probe-Box Interface Bus</b> . . . . .	<b>63</b>
<b>C</b>	<b>Collector-Box Emulator Software</b> . . . . .	<b>65</b>
	Overview . . . . .	65
	Hardware Requirements . . . . .	65
	RS-485 Interface Card . . . . .	65
	RS-485 Interface Adapter . . . . .	66
	Installing the Software . . . . .	67
	Using the Software . . . . .	68
	Main Menu Options . . . . .	68
	Menu Option T . . . . .	69
	Menu Option P . . . . .	70
	The PC Collector-Box Menu . . . . .	71
	Menu Option S . . . . .	73
	Menu Option Q . . . . .	73
	Upgrading the Software . . . . .	73
	Parts of the Emulator Software . . . . .	73
	Parts of the Microprocessor Software . . . . .	74
	Upgrading the Microprocessor Software . . . . .	74
	Communications Mode Selection . . . . .	75
<b>D</b>	<b>Controller Board LEDs</b> . . . . .	<b>77</b>
<b>E</b>	<b>Digi-Bridge Board Critical Component Locations</b> . . . . .	<b>79</b>
<b>F</b>	<b>Controller Board Critical Component Locations</b> . . . . .	<b>81</b>
<b>G</b>	<b>Probe-Box Motherboard Critical Component Locations</b> . . . . .	<b>83</b>
<b>H</b>	<b>Collector-Box Motherboard Critical Component Locations</b> . . . . .	<b>85</b>

Figure 1	The Sierra Thermal Principle . . . . .	3
Figure 2	Proper Probe Orientation . . . . .	6
Figure 3	Typical System Field Wiring Diagram . . . . .	8
Figure 4	Sensor Terminal Strip Wiring Diagram A . . . . .	9
Figure 5	Sensor Terminal Strip Wiring Diagram B . . . . .	9
Figure 6	Probe Head Terminal Strip Layout . . . . .	10
Figure 7	Digi-Bridge Board Sensor Wiring . . . . .	10
Figure 8	Equal Area Traverse for Round Ducts Larger Than 6-inch Diameter . . . . .	23
Figure 9	AC Power Input Wiring Terminals . . . . .	32
Figure 10	Signal Wiring . . . . .	32
Figure 11	Collector-Box Relay Outputs . . . . .	34
Figure 12	Locating the Collector-Box Latch . . . . .	53
Figure 13	Releasing the Collector-Box Latch and Opening the Display Panel . . . . .	53
Figure 14	The Power Supply Fuses . . . . .	54
Figure 15	115 VAC vs. 230 VAC Fuses . . . . .	54
Figure 16	RS-485 Interface Adapter Using 25-pin D Shell Serial Port . . . . .	66
Figure 17	RS-485 Interface Adapter Using 9-pin D Shell Serial Port . . . . .	67
Figure 18	Main Menu . . . . .	68
Figure 19	Error Screen . . . . .	69
Figure 20	PC Collector-Box Menu . . . . .	70
Figure 21	RS-232 Communications Adapter . . . . .	74
Figure 22	Controller Board Communications Connector and Mini-Jumper . . . . .	75
Figure 23	Digi-Bridge Board Communications Connector and Mini-Jumper . . . . .	75



Table 1	Recommended Wire Gauge (A.W.G.) for 115 (230) VAC Mains Power . . .	12
Table 2	Recommended Wire Gauge (A.W.G.) for 24 VDC Power . . . . .	13
Table 3	Signal Wiring, Series 670 Digital Flow Averaging Array . . . . .	14
Table 4	Minimum Number of EPA Method 1 Monitoring Points . . . . .	21
Table 5	Signal Wiring . . . . .	33
Table 6	Relay Board Terminal Assignments . . . . .	35
Table 7	Collector-Box Screens . . . . .	42
Table 8	Flow Readout Options . . . . .	49
Table 9	Troubleshooting . . . . .	58
Table 10	System Specifications . . . . .	61
Table 11	RS-485 Interface, REV. 1.02 . . . . .	64



---

## Series 670 Digital Flow Averaging Array

---

This technical manual describes the Series 670 Digital Flow Averaging Array, the most advanced flow monitoring system ever designed and manufactured by Sierra Instruments.

**Overview** 1

Warning messages (preceded by **WARNING!**) indicate that when a specific procedure or practice is not followed correctly, personal injury could result.

**About the  
Operators  
Manual** 1.1

Caution messages (preceded by **CAUTION!**) appear before some procedures in the text. If these messages are not observed, damage to the equipment could result.

Text appearing **<LIKE THIS>** denotes operator buttons on the Collector-Box front panel.

Within the text the terms flow array, mass flow array, flow averaging array, and Series 670 Digital Flow Averaging Array are used interchangeably.

This manual contains fourteen sections, eight appendices, and an index.

- Section 1, this section, gives an overview of the technical manual.
- Section 2 describes the principles of operation of the Steel-Trak FR sensor.
- Sections 3 and 4 discuss installation and use of the flow averaging array probes and Probe-Boxes.
- Sections 5 and 6 provide additional information about flow monitoring.
- Section 7 explains system maintenance procedures.
- Sections 8, 9, and 10 discuss installation and use of Collector-Boxes.
- Sections 11 and 12 explain maintenance and calibration procedures about Collector-Boxes.
- Section 13 contains troubleshooting information for a Series 670 Digital Flow Averaging Array and 920 Collector-Box.
- Section 14 describes the procedures for returning part or all of your system to Sierra Instruments for repair or recalibration.
- Appendix A provides specifications for the Series 670 Digital Flow Averaging Array.

---

## Series 670 Digital Flow Averaging Array

---

- Appendix B describes the RS-485 communications interface.
- Appendix C explains the use of Collector-Box Emulator software and the hardware that it requires.
- Appendix D describes the locations and use of the LEDs on the Controller board.
- Appendices E, F, G, and H show critical component locations for a Digi-Bridge board, a Probe-Box Controller board, a Probe-Box motherboard, and a Collector-Box motherboard, respectively.

Sierra's unique Steel-Trak FR sensors are responsible for the accuracy, ruggedness, and reliability of Sierra flow arrays.

Each sensing point has two sensors: a velocity sensor and a temperature sensor that automatically correct for temperature changes. Both sensors are reference-grade platinum resistance temperature detectors (RTDs).

The stability and repeatability of RTDs has made them the NIST standard. The platinum RTD wire is wound on a rugged ceramic mandrel for strength and stability. Steel-Trak FR sensors are clad in an exceptionally rugged, sealed, 316 stainless steel enclosure, or thermowell.

Figure 1  
The Sierra Thermal Principle

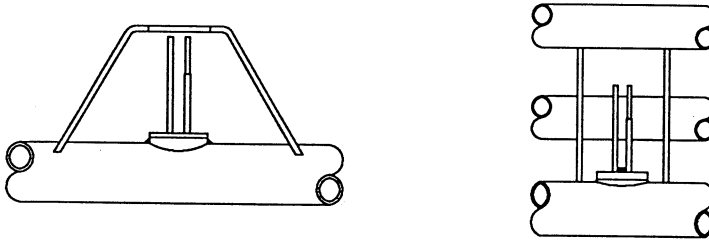

A circuit heats the velocity sensor at a constant temperature differential,  $T_v - T_T$ , above ambient and measures the cooling effect of the air flow. The resulting output provides low-speed sensitivity and a rangeability of 1000:1. Velocities as low as 10 SFPM and as high as 12,000 SFPM are easily resolved. Since the heat is carried away by the molecules in the air (see Figure 1), the heated sensor directly measures air mass velocity referenced to standard conditions of 70°F (21.1°C) and one atmosphere. In the case of duct flows, the Sierra flow arrays monitor the average mass velocity over the entire cross section of the duct or pipe, which, when multiplied by the cross-sectional area, yields the total mass flow rate in SCFM. The flow averaging procedure is described in Section 5.

Mass flow rate is frequently the quantity of direct interest in combustion, heat transfer, and any chemical process. However, if the actual velocity in FPM or the flow rate in CFM is desired, the operator simply can multiply the reading by the ratio of the standard air density to the actual air density, as shown in Section 6.

---

## Series 670 Digital Flow Averaging Array

---

**WARNING!** Sierra Instruments flow arrays are not approved by any testing agency for installation in a hazardous location. If an application requires maximum safety, you must use an optional explosion proof enclosure and place all wiring in solid metal conduit according to NFPA approved practices for the specific rating required. You must also ascertain that there is no need for an explosion-proof assembly within the duct or pipe. The sensors themselves have the potential, in the Auto-Self Clean mode, to heat up to 400°C.

**WARNING!** All installation procedures must be performed with the power off. For all installations of flow arrays, standard industrial wiring practices apply. Local codes typically require the use of solid metal conduit. For explosion proof enclosures, solid metal conduit is mandatory. In general, the use of solid metal conduit is recommended as good wiring practice.

Due to the highly application-specific nature of multi-point flow measurement systems, please refer to the following installation suggestions, Appendix A, *Specifications*, and the Sierra Instruments engineering drawings supplied with your system (these are the drawings that were approved by your design engineers).

**Note:** If your system contains a Collector-Box, refer to Section 8, *Collector-Box Installation*.

- In general, you should install probes three-quarters of the way down the longest straight length of duct or stack available. Ideally, thirty pipe diameters (minimum) straight run upstream and ten pipe diameters (minimum) straight run downstream provide maximum accuracy. Twenty diameters upstream and five diameters downstream can yield acceptable results if the system can be calibrated in situ and the flow profile is consistent over the entire range.
- Particulate build-up on probes mounted in ducts is generally heavier and more difficult to remove than particulate build-up on probes mounted in stacks. If you have a choice where to mount the probes, stack mounting is preferable to duct mounting from a maintenance standpoint.
- Particulate build-up on probes mounted in close proximity to a boiler is heavier and more difficult to remove than particulate build-up on probes mounted well away from a boiler. If you have a choice where to mount the probes, keep them after precipitators as far from boilers as possible.

**Installation** 3

**Mounting of Probes and Probe-Boxes** 3.1

---

## Series 670 Digital Flow Averaging Array

---

- When the probes are installed and electrical power is applied to them, the thermophoretic force generated by the heating of the sensors will keep the sensors free from particulate build-up. However, when power to the system is turned off, particulate build-up can become so significant that even the Auto-Self Clean function will be unable to remove it. Thus, after installing the probes, turn on power to the system as quickly (ideally, within fifteen minutes) as possible.
- Your flow array has been designed so that the sensing point of each mass flow sensor is located at the approximate center (centroid) of equal areas, if possible.
- Check the sensor element orientation so that flow passes directly through the sensor shields. The plane of the sensor shields in a probe should be perpendicular to the axis of the duct or pipe, within a  $\pm 5^\circ$  pitch angle and a  $\pm 5^\circ$  yaw angle. The arrow on the flange indicates the direction of flow. Refer to Figure 2.

Figure 2  
Proper Probe  
Orientation

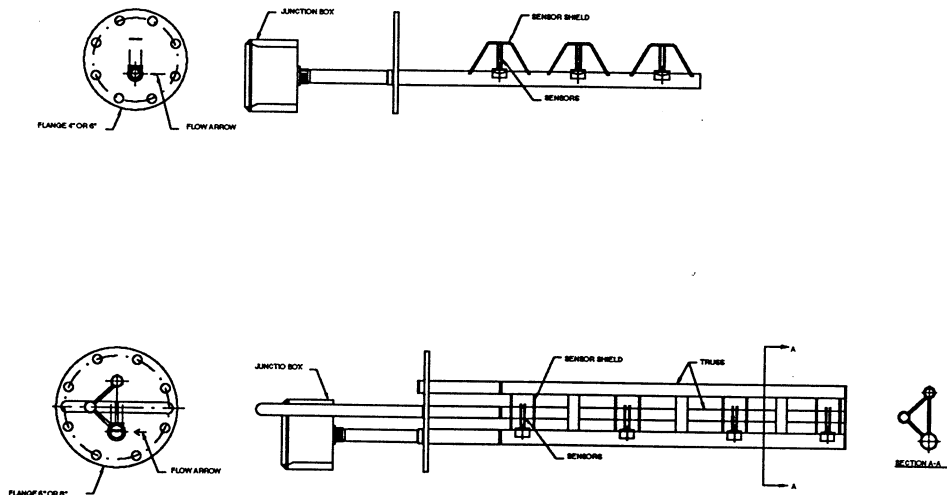

---

## Series 670 Digital Flow Averaging Array

---

- Check the system for upstream anomalies; e.g., leaks or valves that might drastically change flow rate unexpectedly or cause turbulence, heaters that might cause rapid temperature excursions, etc.
- Although the sensing elements are rugged, take care not to damage them during installation.
- Probes are mounted on 4-inch diameter, 150 pound flanges. A 6-inch, 150 pound flange is optional.
- For measuring low flows, it is important that the probe be mounted securely to the flange to ensure accurate results.
- Mount the Probe-Box in a dry, vibration-free location where the temperature remains between 32-122°F (0-50°C). We strongly recommend that you connect purge air to the enclosure even if it is not exposed to weather.
- Install an in-line power switch in the AC line to the Probe-Box, even though the Probe-Box has its own power switch.
- Finally, check the label on the Probe-Box to verify that it has been built in accordance with your known system pressure, temperature, gas composition, power input, and signal output.

Field wiring for a typical Series 670 Digital Flow Averaging Array is on terminal strips within the probe heads and also on terminal strips in the Probe-Boxes and Collector-Boxes. (See Figure 3 for a typical system wiring scheme and Section 8, *Collector-Box Installation*, for illustrations of Collector-Box field wiring.)

**Access to Field  
Wiring 3.2**

Field wiring of *sensors* is on terminal strips within the probe heads (see Figures 4, 5, and 6) and within Probe-Boxes on the Digi-Bridge boards (Figure 7).

Field wiring for Probe-Boxes and between Probe-Boxes and Collector-Boxes is located on terminal strips within the electronics enclosures. (See your approval drawings, Figures 3, 9, and 10, and Appendices G and H for locations of the terminal strips).



# Series 670 Digital Flow Averaging Array

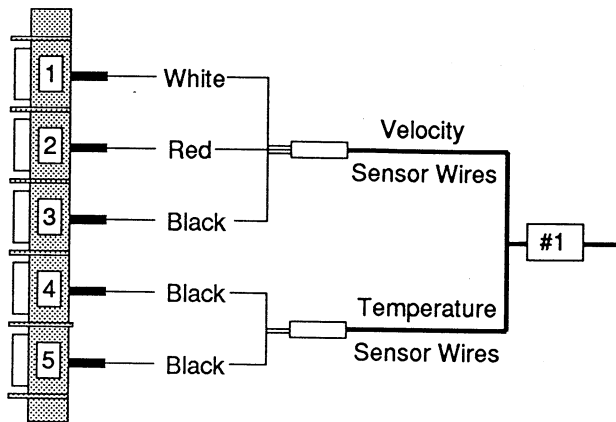

Figure 4  
Sensor Terminal Strip  
Wiring Diagram A

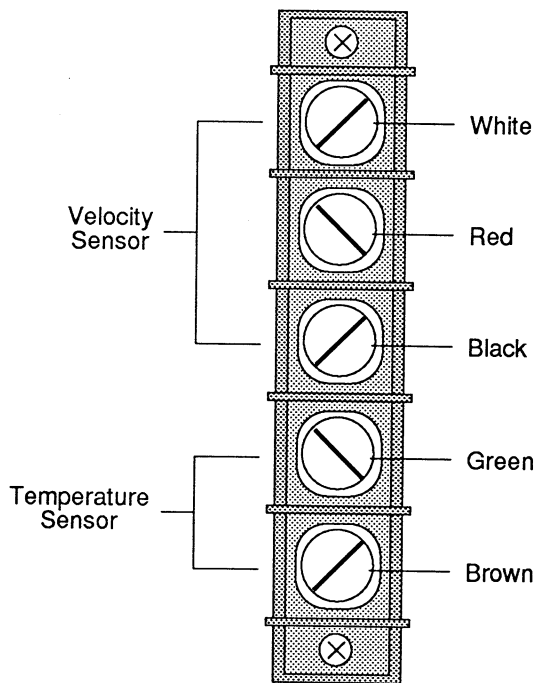

Figure 5  
Sensor Terminal Strip  
Wiring Diagram B

# Series 670 Digital Flow Averaging Array

Figure 6  
Probe Head  
Terminal Strip  
Layout

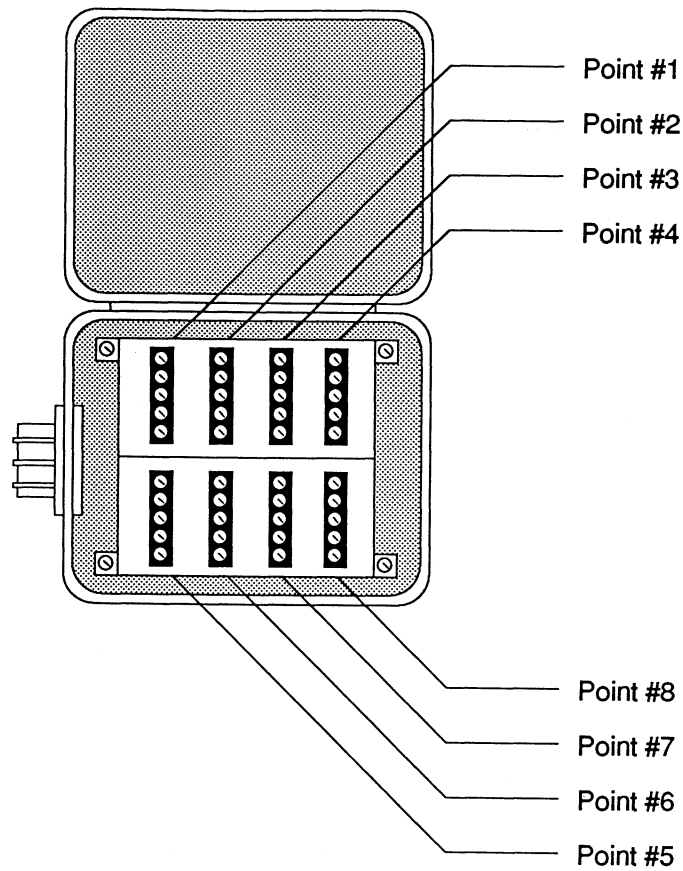
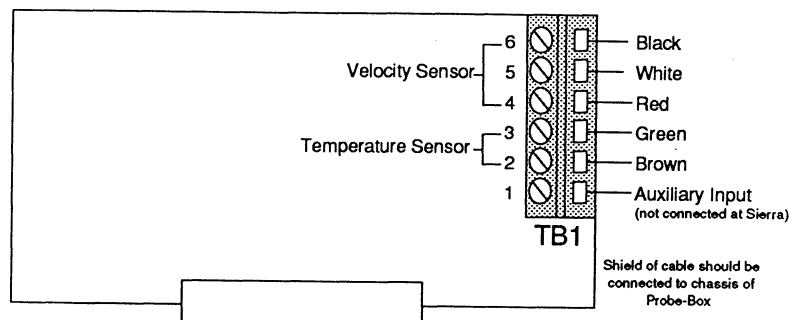

Figure 7  
Digi-Bridge Board  
Sensor Wiring



---

## Series 670 Digital Flow Averaging Array

---

**WARNING!** Normally, 24 VDC power is utilized for short to moderate runs, safety, or because it is readily available. It is usually considered safer than 115/230 VAC mains power due to its much lower shock hazard, although it is no safer than 115/230 VAC mains power from the point of view of hazardous atmospheres.

**Power Supply  
Wiring** 3.3

Refer to Section 3.2 for instructions on locating the field wiring.

A three-circuit terminal strip within the electronics enclosure is marked for power wiring. Connect the wiring in accordance with your approval drawings.

Select one of the available 3/4" female NPT entry ports on the Probe-Box when connecting power. Use one or more of the other NPT ports for signal wiring. This will help keep low level, isolated signals from contacting power supply voltages.

**CAUTION!** Be sure that your Probe-Box is equipped for 100/115/230 VAC input power by checking the serial number label on the outside of the unit.

**100/115/230  
VAC 50/60 Hz  
Input Power** 3.3.1

The load represented by a flow array is about 15 VA (500mA) maximum per point. See Table 1 for recommended wire gauge versus distance from power source. Local electrical codes may require heavier gauge wire than called for by the table.

## Series 670 Digital Flow Averaging Array

Table 1  
Recommended Wire  
Gauge (A.W.G.) for  
115 (230) VAC Mains  
Power

Number of Points	Length of Run in Feet (Meters)					
	100 (30)	500 (150)	1000 (300)	2000 (600)	3000 (900)	4000 (1200)
4	14 (14)	14 (14)	14 (14)	14 (14)	14 (14)	12 (14)
8	14 (14)	14 (14)	14 (14)	12 (14)	10 (12)	8 (12)
12	14 (14)	14 (14)	12 (14)	10 (12)	8 (10)	6 (8)
20	14 (14)	14 (14)	10 (12)	8 (10)	6 (8)	4 (6)
30	14 (14)	12 (14)	8 (12)	6 (8)	4 (6)	2 (4)
40	14 (14)	10 (12)	6 (10)	4 (6)	2 (6)	2 (4)
50	14 (14)	8 (12)	6 (8)	4 (6)	2 (4)	* (4)

\* Not Recommended, requires greater than 2 gauge.

\*\* Based on maximum voltage drop of 5 volts for 115 VAC and 10 volts for 230 VAC Mains, 15 VA loads and the following wire data of ohms/1000 feet for 2 conductors: 14 ga. 5.15, 12 ga. 3.24, 10 ga. 2.04, 8 ga. 1.28, 6 ga. .81, 4 ga. .51, 2 ga. .32.

### 3.3.2 24 VDC Input Power

**CAUTION!** Be sure that your Probe-Box is equipped for 24 VDC input power by checking the serial number label on the outside of the unit.

The load represented by a flow array is about 15 VA (500mA) maximum per point. See Table 2 for recommended wire gauge versus distance from power source.

## Series 670 Digital Flow Averaging Array

Table 2  
Recommended Wire  
Gauge (A.W.G.) for 24  
VDC Power

Number of Flow Meters	Length of Run in Feet (Meters)						
	25 (8)	100 (30)	500 (150)	1000 (300)	2000 (600)	3000 (900)	4000 (1200)
4	14 (14)	14 (14)	8 (12)	4 (10)	2 (6)	* (4)	* (4)
8	14 (14)	12 (14)	4 (10)	2 (6)	* (4)	* (2)	* (*)
12	14 (14)	10 (14)	2 (8)	* (4)	* (4)	* (*)	* (*)
20	14 (14)	8 (14)	* (6)	* (2)	* (*)	* (*)	* (*)

\* Not Recommended, requires greater than 2 gauge.

\*\* Based on a maximum voltage drop of 4 volts for 24 VDC.

**CAUTION!** The cable supplied by Sierra Instruments to interface a sensor with a bridge board in a Probe-Box is calibrated as an integral part of the precision flow measurement circuit. Although a 5-wire bridge with cable compensation is used, if the cable length is changed, either by making it longer or shorter, the accuracy of the flow array may be impaired.

The following sections describe signal wiring for the Series 670 Probe-Box. Signal wiring at the flow array is via terminal strips. Refer to Table 3 for a general description of the signal wiring for the Series 670 Digital Flow Averaging Array.

For all Probe-Boxes, standard industrial wiring practices apply. Local codes typically require the use of solid metal conduit. For Probe-Boxes in explosion proof enclosures, the use of solid metal conduit is mandatory. In general, the use of solid metal conduit is recommended as good wiring practice.

**Remote Probe Wiring (350 feet maximum)** 3.4

**Signal Wiring** 3.5

Table 3  
Signal Wiring,  
Series 670 Digital  
Flow Averaging Array

Analog Signal Name	Description
4-20mA Output	4-20mA output representing measured flow value
Ground	Analog ground for 0-5 VDC and 4-20mA reference
0-5 VDC	0-5 VDC output representing measured flow value
Digital Signal Name	Description
Ground	Ground reference for RS-485 shield
RS-485(+)	(+) of RS-485 interface for Collector-Box and SierraNet
RS-485 (-)	(-) of RS-485 interface for Collector-Box and SierraNet

Note: Depending on the model, your flow array might not have all the signals listed.

### 3.5.1 0-5 VDC and 4-20mA Outputs

All Probe-Boxes are equipped to provide both 0-5 VDC and 4-20mA output signals. These signals are 0-100% linear representations of full-scale. Check the serial number label on the outside of the enclosure for the full-scale value and calibration gas for the Probe-Box.

The 0-5 VDC signal can drive a load resistance from 1,000-2,000 ohms and is output from “0-5 VDC” and “GND.”

The 4-20mA signal can source up to 500 ohms including drops in the signal wire and is output from “4-20mA” and “GND.”

**Note:** This is not a loop powered device.

---

## Series 670 Digital Flow Averaging Array

---

### RS-485 Interface 3.5.2

Included in the Probe-Box is an EIA standard RS-485, serial, bi-directional interface. This interface allows up to ten Probe-Boxes (containing a maximum of 32 sensor points in various configurations) to be daisy-chained on a single twisted-pair plus shield cable. Maximum distance is 4,000 feet (1,200 meters) using 24-gauge, shielded, twisted-pair cable.

If you have a system that includes a Collector-Box or a PC-compatible computer using Collector-Box Emulator software, the RS-485 interface is transparent and all the details of interface protocol are handled by the Collector-Box or computer software.

If your system uses a IBM-compatible computer and Collector-Box Emulator software, the computer must contain an RS-485 interface card or RS-485 interface adapter configured as a serial communications (COM) port.

The RS-485 interface card, Sierra part number 65-0054, may be installed in either an expansion slot of the computer or connected externally to an RS-232 COM port. (If more than one card is used, only one may be connected at a time, and the wiring to the others must be disconnected.)

An RS-485 interface adapter is available from Sierra Instruments or Telebyte Technology, Inc. (Call Telebyte Technology at 1-800-835-3298 and ask for their Model 266F.)

Refer to Appendix B for a detailed description of the RS-485 protocol.

---

**Series 670 Digital Flow Averaging Array**

---

---

## Series 670 Digital Flow Averaging Array

---

**CAUTION!** Before turning on the power for the first time, double check all power and signal wiring, especially the wiring in the probe head and on the Digi-Bridge boards.

**Operating Instructions** 4

There are two configurations for Series 670 Digital Flow Averaging Arrays:

**General Description** 4.1

- **Flow array with Collector-Box**—0.5 VDC and 4-20mA analog outputs are available from the Collector-Box. These linear outputs, which are proportional to flow, may be biased in the Collector-Box. (If your system contains a Collector-Box, refer to Section 9, *System Configuration*, before proceeding.)
- **Flow array alone**—0.5 VDC and 4-20mA analog outputs are available from each Probe-Box. These linear outputs are proportional to the flow. (This option does not meet EPA CEMS requirements.)

After applying power to the Probe-Boxes (and the Collector-Box if it is installed), watch the for the flow to go high. It is normal for this condition to persist for a few seconds during which time the velocity sensors are heating to their operating temperature. Then the flow indication will rapidly approach the value of the flow (or zero if no flow is present). After several minutes, the system attains maximum accuracy. (You can turn the system on or off at any time without fear of damage.)

**CAUTION!** We recommend that you leave the system turned off for no more than 15-20 minutes at a time if the probes are in a particularly dirty atmosphere. Particulate, if it is present, will build-up on the sensors when the system is turned off, because the sensors are not being heated.

The Probe-Box motherboard contains eight LEDs, one for each of the Digi-Bridge boards that may be installed. Under normal operating conditions, the LED adjacent to each installed Digi-Bridge board is on—indicating that the Controller board is able to communicate with the Digi-Bridge board.

**Probe-Box Motherboard LEDs** 4.2

If one or more LEDs is off, it may indicate that (1) the Digi-Bridge boards (or the Controller board) are in RS-232 MODE (see Appendix C, *Collector-Box Emulator Software*, for an explanation) or (2) there is a communications problem between the Digi-Bridge boards and the Controller board.

The Controller board contains six LEDs. They provide different information depending on the Probe-Box's current operating condition. See Appendix D, *Controller Board LEDs*, for detailed information about these LEDs and their functions.

**Controller Board LEDs** 4.3

**4.4 Calibration Voltage Output Switch, SW1**

There are three pushbutton switches on the Controller board, only one of which (SW1) is currently functional. This switch forces the Probe-Box to generate, in sequence, a series of fixed (analog and digital) calibration outputs of 100% of full scale, 75%, 50%, 25%, 0%, and a return to normal flow with the sixth toggle. The outputs, which change each time the operator toggles the pushbutton, can be read at the analog output of the Probe-Box or on the RS-485 interface to the Collector-Box. The Probe-Box returns to normal operation about five minutes after the last toggle of the switch.

**4.5 Output Select Jumper (JB4)**

A Probe-Box always generates two primary outputs:

- 1 an RS-485 *digital* output, which contains both flow and temperature data. This output is always enabled and is normally connected to a Collector-Box or an IBM-compatible computer running Collector-Box Emulator software.
- 2 0-5 VDC or 4-20mA *analog* outputs, which can represent either (a) the average flow of all the sensor points connected to the Probe-Box or (b) the average temperature.

Jumper JB4 on the Probe-Box motherboard establishes whether the analog output will represent flow or temperature.

If jumper JB4 is removed, the average flow of all the sensor points connected to the Probe-Box can be read from either analog output. The analog outputs are linearly proportional to the full scale flow specification that is stored in the microprocessor memory of the Controller board mounted on the motherboard.

If jumper JB4 is installed, the average temperature of all the sensor points connected to the Probe-Box can be read from either analog output. The analog outputs are linearly proportional to the zero and full scale temperature specification that is stored in the microprocessor memory of the Controller board mounted on the motherboard.

**4.6 Digi-Bridge Board Outputs**

Jumper JB4 also toggles (between flow and temperature) the analog outputs of the individual Digi-Bridge boards mounted in the Probe-Box.

The individual analog outputs of the Digi-Bridge boards can be found on a set of terminal strips, TB5 (points 1 through 4) and TB1 (points 5 through 8), mounted on the edge of the Probe-Box motherboard. The terminal strips are numbered, 1 through 8, to correspond with the Digi-Bridge boards. (See Appendix G, *Probe-Box Motherboard Critical Component Locations*.)

The same criteria apply to the Digi-Bridge board analog outputs as those that apply to the Probe-Box analog outputs (see Section 4.5).

---

## Series 670 Digital Flow Averaging Array

---

### Monitoring Total Flow Rate

5

A Series 670 Digital Flow Averaging Array monitors the total flow rate in ducts or pipes by monitoring the point velocity at the centroid of equal areas in the flow monitoring plane. As shown in Equation (1), each Probe-Box computes the average of the point velocities of its probe(s). The grand average of the average velocities from all the Probe-Boxes is averaged by the Collector-Box electronics. Each Probe-Box can average up to eight sensors. A Collector-Box can average up to 32 sensor points. The grand average velocity is computed as follows:

$$\bar{V}_s = \left( \frac{1}{n} \right) \sum_{i=1}^n V_{s,i} \quad (1)$$

where:

- $\bar{V}_s$  = the grand average standard mass velocity over the cross-sectional area of duct or pipe referenced to standard temperature and pressure (SFPM or SMPS)
- $V_{s,i}$  = individual point standard mass velocity at the centroid point of each equal area referenced to standard temperature and pressure (SCFM or SMPS)
- $n$  = the total number of equal areas in the monitoring plane. Standard temperature is 21.1°C, 294.1°K, 70°F, or 530°R; standard pressure is 760 mm of mercury or 14.7 psig

The output of the flow array can be either  $\bar{V}_s$  as shown above in Equation (1), the total standard volumetric flow rate as shown in Equation (2) below, or the total mass flow rate as shown in Equation (3) below:

$$Q_s = \bar{V}_s A \quad (2)$$

where:

- $Q_s$  = total standard volumetric flow rate (SCFM or  $\text{Sm}^3/\text{hr}$ )
- $A$  = the cross-sectional area of the duct or pipe ( $\text{ft}^2$  or  $\text{m}^2$ ).

$$\dot{m} = \rho_s Q_s \quad (3)$$

where:

- $\dot{m}$  = the total mass flow rate (Lbm/hr, Kg/s)
- $\rho_s$  = the mass density of the gas at standard temperature and pressure

The proper units for the flow display are selected by a potentiometer in the Probe-Box and by the keyboard in the Collector-Box. Section 6, *Calculating Actual Flow Rates*, shows how to correct  $V_s$  and  $Q_s$  to conditions of actual temperature with pressure.

Example calculation:

Let's use an example and the above equations to calculate the average air flows for the following set of data:

$$V_{s,1} = 1,500 \text{ SFPM}$$

$$V_{s,2} = 1,800 \text{ SFPM}$$

$$V_{s,3} = 1,400 \text{ SFPM}$$

$$V_{s,4} = 1,700 \text{ SFPM}$$

$$A = 16 \text{ ft}^2$$

$$\rho_s = 0.075 \text{ Lbm/ft}^3 \text{ for air}$$

Using Equations (1), (2), and (3), we get:

$$\bar{V}_s = \frac{1500 + 1800 + 1400 + 1700}{4} = 1600 \text{ SFPM}$$

$$Q_s = 1600 \times 16 = 25,600 \text{ SCFM, and}$$

$$\dot{m} = \rho_s Q_s = 0.075 \frac{\text{Lbm}}{\text{Sft}^3} \times 25,600 \frac{\text{Sft}^3}{\text{Min}} = 1920 \frac{\text{Lbm}}{\text{Min}}$$

$$\dot{m} = 1920 \frac{\text{Lbm}}{\text{Min}} = 32 \frac{\text{Lbm}}{\text{Hr}}$$

---

## Series 670 Digital Flow Averaging Array

---

For purposes of in-line calibration, the Environmental Protection Agency's Methods 1 and 2 apply.

**Stack and Flue Monitoring**      **5.1**

Method 1 specifies the number of equal areas that must be measured in a given duct. Method 2 specifies the S-type Pitot tube used during tests. Thus, Method 1, by definition, specifies the number of sensor points that must be contained in a Series 670 Digital Flow Averaging Array designed for a particular application.

**NOTE:** Occasionally, the EPA allows for some relaxation of Method 1 requirements; applications with uniform flows may not require as many sensor points as stipulated by a strict interpretation of Method 1.

The minimum number of monitoring points specified by EPA's Method 1 is given in the following table:

*Table 4  
Minimum Number of EPA  
Method 1 Monitoring  
Points*

Stack Diameter (or Equivalent Diameter)	Number of Monitoring points
12-24 inches	8 (Circular stacks)
12-24 inches	9 (Rectangular stacks)
Over 24 inches	12 (Circular or rectangular)

After the number of monitoring points is determined, divide the stack's cross-section into equal areas. The flow meter's sensors should be located in the centroid of each equal area. Table 5 gives the EPA's recommendation for the size of each equal area for square or rectangular cross sections. The dimensions of each area can be modified provided the cross-sectional area is the same. (See Figure 8.)

For rectangular ducts, the following notes should be taken into account.

- At least 12, but not more than 32, readings should be taken at centers of equal areas.
- If fewer than 32 readings are taken, the traverse points should not be more than six inches center-to-center.

---

## Series 670 Digital Flow Averaging Array

---

- If 32 readings are taken, the traverse points may be more than six inches center-to-center.

As discussed in Section 5, Sierra measures the “standard” volumetric flow rate  $Q_s$  referenced to 70°F (21.1°C) and one atmosphere (760 mm of mercury). The units of measurement are standard cubic feet per minute (SCFM) or standard cubic meters per hour ( $Sm^3/hr$ ). In most monitoring applications,  $Q_s$  is the quantity of direct interest. However, in some cases the actual volumetric flow rate,  $Q$ , is desired. This is obtained by applying a correction factor given by the following equation:

$$Q = Q_s \left( \frac{\rho_s}{\rho} \right) = Q_s \left( \frac{P_s}{P} \right) \left( \frac{T}{T_s} \right) \quad (1)$$

where:

- $Q$  = “actual” volumetric flow rate at conditions of  $P$  and  $T$  ( $m^3/hr$ , CFM)
- $Q_s$  = “standard” volumetric flow rate referenced to standard conditions of  $P_s$  and  $T_s$  ( $Sm^3/hr$ , SCFM),
- $\rho$  = gas mass density at actual conditions, g/cc
- $\rho_s$  = gas mass density at standard conditions 1.200 g/cc or 0.075 Lbm/ft<sup>3</sup>
- $T$  = gas temperature at actual conditions, °K
- $T_s$  = standard gas temperature = 21.1°C = 294.3°K = 70°F = 529.7°R
- $P$  = gas pressure at actual conditions, mm of mercury or psig
- $P_s$  = standard gas pressure = 760 mm of mercury or 14.7 psig

The same relationship holds for correcting  $V_s$ (SFPM) to  $V$ (FPM).

Example calculation:

Your flow meter shows a reading of 800 SCFM. The gas temperature is 150°F. The gas pressure is 200 psig. From Equation (1), the actual volumetric flow rate  $Q$  is calculated as:

$$Q = 800 \left( \frac{14.7}{14.7 + 200} \right) \left( \frac{150 + 459.7}{529.7} \right) = 63.0 \text{ CFM}$$

---

**Series 670 Digital Flow Averaging Array**

---

---

## Series 670 Digital Flow Averaging Array

---

**WARNING!** Before attempting any maintenance, make sure there is no pressure in the line in which the probes are installed.

**WARNING!** Gas leaks are possible during probe maintenance. Make sure the lines are completely purged before removing the probe.

**WARNING!** All maintenance, including cleaning operations, must be carried out with the power off.

**CAUTION!** Changing the output signal from the Probe-Box, by adjustment potentiometers, turning off power, etc., may affect other plant equipment, alarm outputs, etc.

The Probe and Collector-Box main printed circuit assemblies (PCAs) are readily accessible after opening the enclosure. The power supply PCA is located beneath the motherboard PCA.

The totalizer back-up battery normally lasts six years. To replace the battery, return the Probe-Box to Sierra Instruments. If your flow array requires calibration, return the entire system. Refer to Section 14, *Sierra Repair*, for instructions on returning the flow array.

Steel-Trak probes are insensitive to small amounts of contamination or dirt; a little contamination or discoloration will not affect accuracy. However, the sensors should be inspected and, if necessary, cleaned periodically, normally during a plant shutdown or prior to a relative accuracy test audit (RATA).

To inspect the sensor elements, remove the probe from the duct or stack to reveal the sensor elements (two stainless steel encasements, or thermowells).

If the sensors are visibly coated with dust or powder-like particulate, use a small, soft brush to remove the contamination. If the sensors are coated with a particulate that cannot be removed with light, dry brushing, use a small brush moistened with water or alcohol (ethanol) to remove the contamination. Finally, if the sensors cannot be cleaned using these procedures, try scraping them lightly until they appear clean again.

**CAUTION!** Avoid using excessive pressure if you must scrape the sensor elements to clean them.

If sensors are broken or damaged, they usually may be replaced in the field (see Section 7.5, *Replacing Sensors*). This involves probe disassembly, replacement of both the temperature and velocity sensor, and either installation of a new Digi-Bridge board or loading the specifications of a new sensor pair into the old Digi-Bridge board. Sensors and Digi-Bridge boards must be matched to one another.

### System Maintenance 7

#### Access to Electronics PCAs 7.1

#### Totalizer Back-up Battery 7.2

#### Probe Cleaning 7.3

#### Probe Breakage or Damage 7.4

### 7.5 Replacing Sensors

You can replace sensors in the field if this should become necessary. If you do replace a sensor pair, we recommend that you replace the Digi-Bridge board associated with that sensor pair, as well. That is, replace the old, matched, sensor/Digi-Bridge board assembly with a complete, new assembly.

**WARNING!** Before performing any work on a probe, ensure that power to the Probe-Box is turned off.

**NOTE:** We strongly recommend that you contact Sierra Instruments Customer Service before replacing sensors in order to let them know what you are doing and why you are doing it.

#### 7.5.1 Required Tools and Supplies

You will need the following tools/supplies to replace a sensor pair:

- medium flat-blade screwdriver
- medium Phillips screwdriver
- Channel-Locks or other large pliers
- wrenches suitable for removing your flanges
- soldering iron and solder
- heat-shrink tubing
- high-temperature silicon
- vacuum grease
- new set of O-rings
- new sensor pair
- two lengths of wire that are at least two feet longer than the distance from the probe head to the sensor pair you are replacing

#### 7.5.2 Sensor Replacement Procedure

When you have assembled the necessary tools and supplies, refer to the following procedure.

- 1 Turn off power to the Probe-Box.
- 2 Disconnect probe head to Probe-Box interface cables from all terminal strips in the probe head.
- 3 Disconnect the conduit containing the sensor cables from the probe head, and pull the cables out of the probe head.

---

## Series 670 Digital Flow Averaging Array

---

- 4 Remove the probe from the duct/stack.
- 5 Remove the terminal strip mounting plate(s) from the probe head.
- 6 Remove the high-temperature silicon dam from the probe head.

**CAUTION!** Do not scrape the Teflon insulation from or break sensor wires when removing the silicon dam from the probe head.

- 7 Locate the terminal strip associated with the sensor pair you want to replace, and remove the screws holding that terminal strip to the terminal strip mounting plate.
- 8 Pull the terminal strip out from the terminal strip mounting plate about three inches, and cut the five wires of the sensor pair you want to replace. (See Figure 4 in Section 3, Installation.)
- 9 Remove the heat-shrink tubing and any excess wire and solder from the terminals on the back of the terminal strip.
- 10 Strip a half inch of insulation from the ends of the two, black, temperature sensor wires, and solder a length of wire to them.

**NOTE:** The length of wire should be at least two feet longer than the distance between the probe head and the sensor pair you want to replace.

- 11 Strip a half inch of insulation from the ends of the three, velocity sensor wires (white, Red, and black), and solder a length of wire to them.

**NOTE:** This length of wire also should be at least two feet longer than the distance between the probe head and the sensor pair you want to replace.

- 12 Tie the ends of the two lengths of wire to the handle on the flange.

**NOTE:** This step is *very* important.

- 13 Locate sensor assembly you want to replace, and remove the two screws that fasten the assembly to the probe shaft.

**NOTE:** If possible, use new screws when reassembling.

---

## Series 670 Digital Flow Averaging Array

---

- 14 Slowly, begin pulling the sensor assembly away from the probe shaft, trailing the sensor wires that lead back into the probe shaft.

**NOTE:** Verify that the lengths of wire you soldered to the other ends of the sensors wires are feeding into the head of the probe shaft without kinking. If the wires get hung up, work them back and forth in the probe shaft until you can pull them through without effort.

- 15 When you have pulled the entire length of the wires through the probe shaft (except for the ends that you tied to the flange handle), separate the old sensor wires from the pull wire.

- 16 Disassemble the old sensor assembly.

- 17 Lubricate the replacement O-rings with vacuum grease, and install them and the new sensors on the old sensor assembly.

- 18 Solder the new sensor wires to the two lengths of pull wire.

- 19 Return to the probe head and slowly pull the new sensor wires into the probe shaft.

**CAUTION!** We recommend that you have assistance available when pulling the new sensor wires into the probe shaft. The sensor wires must be guided into the probe shaft carefully so that none of the Teflon insulation on the wires is abraded. If the insulation is damaged during this step, the sensor pair may (1) short circuit to ground in the probe shaft, or (2) exhibit an increase in resistance due to corrosion of the sensor wire.

- 20 After you have pulled most of the sensor wire back through the probe shaft, check that the O-rings are seated properly.

- 21 Push the excess wire into the hole in the probe shaft and use new screws to fasten the sensor assembly to the probe shaft.

**NOTE:** Tighten the screws evenly to ensure that the O-rings seal properly.

**NOTE:** New O-rings are not a guarantee that the probe will be leak-proof. Consult with Sierra Instruments Customer Service for instructions on leak-checking the probe.

---

## Series 670 Digital Flow Averaging Array

---

- 22 Allow about twelve inches of sensor wire to exit the probe head, and cut off the excess.
- 23 Apply enough high-temperature silicon into the head of the probe shaft to create a new dam in the probe.  
**NOTE:** Refer to the silicon manufacturer's instructions on set-up time.
- 24 Cut the pull wires from the new sensor wires.
- 25 Install heat-shrink tubing on the new sensor wires.
- 26 Insert the new sensor wires through the holes in the terminal strip mounting plate.  
**CAUTION!** Double check that you are inserting the sensor wires into the correct holes.
- 27 Solder the wires to the correct terminals on the back of the terminal strip you removed in step #7.
- 28 Shrink the heat-shrink tubing.
- 29 Fasten the terminal strip to terminal strip mounting plate.
- 30 Install the terminal strip mounting plate in the probe head.
- 31 Install the probe in the duct/stack.
- 32 Insert the conduit in the probe head.
- 33 Connect the probe head to Probe-Box interface cables to the terminal strips in the probe head.
- 34A Install and connect a new Digi-Bridge board in the Probe-Box (in the slot associated with the new sensor pair), and proceed to step 35.  
**NOTE:** If you are using the old Digi-Bridge board, proceed to step 34B.
- 34B Call Sierra Instruments Customer Service for information about using the Collector-Box Emulator software to load the new sensor pair constants. Burn new tables for that sensor pair.
- 35 Turn on power to the Probe-Box and verify flow.



---

## Series 670 Digital Flow Averaging Array

---

**WARNING!** The Sierra Instruments Series 920 Collector-Box is not approved by any testing agency for installation in a hazardous location. For applications requiring maximum safety, you must use the optional Sierra explosion-proof enclosure and all wiring must be placed in solid metal conduit.

### Collector-Box Installation 8

**WARNING!** All installation procedures must be performed with the power off.

For all Collector-Box installations, standard industrial wiring practices apply. Local codes typically require the use of solid metal conduit. In general, the use of solid metal conduit is recommended as good wiring practice.

Mount the Collector-Box in a dry, vibration-free location out of direct sunlight and where the temperature remains within 32-122°F (0-50°C). Mount the Collector-Box where the display can be viewed comfortably. (The viewing angle is about 15° to 20° below the level of the liquid crystal display.) We strongly recommend that you connect purge air to the enclosure whether or not it is exposed to weather. (Debris can enter the Collector-Box via the conduit from a Probe-Box.) We also recommend that you install an in-line power switch in the mains power to the Collector-Box.

### Mounting the Collector-Box 8.1

Field wiring for a Collector-Box is located on terminal strips within the electronics enclosure. (See Figures 8 and 9 and Appendix H for wiring diagrams and locations of the terminal strips).

### Access to Field Wiring 8.2

After opening the enclosure, release the black latch on the front panel by rotating it 90° and swing out the front panel. This will expose the motherboard which contains all electronics except the power supply. (The power supply is mounted beneath the motherboard.) On the motherboard there is a 16-point terminal strip (Figure 9) that contains all field wiring except the input for mains power (Figure 8) and the relay-controlled outputs (Figure 10).

**CAUTION!** Be sure that your Collector-Box is equipped for the proper input power by checking the power supply rating on the label.

### 100/115/230 VAC Input Power 8.3

Mains power is connected to the power supply board located on the bottom of the enclosure below the motherboard. If your Collector-Box was supplied with a power cord, either plug this directly into a wall outlet or remove it and wire directly onto the power terminal strip, as detailed below.

## Series 670 Digital Flow Averaging Array

The three-circuit terminal strip on the power supply board is marked for AC power wiring (See Figure 8). The center screw terminal connects to chassis ground. The other two screw terminals are for AC(H) and AC(N).

Select one of the available entry ports on the Collector-Box for connecting power only, using one or more of the other ports for signal wiring. This will help keep low-level, isolated signals from contacting hazardous mains power.

Figure 8  
AC Power Input  
Wiring Terminals

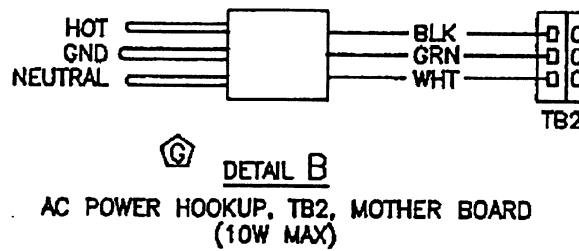

You can locate circuit protective fuses on the power supply board. The load represented by a Collector-Box is about 15 VA (500mA) maximum. Refer to Section 11, *Collector-Box Maintenance*, for further information on fuse type, value in amperes, etc.

### 8.4 Signal Wiring

The following sections describe connecting signal wiring to a Collector-Box. (Refer to Table 5.)

For all Collector-Boxes, standard industrial wiring practices apply. Local codes typically require the use of solid metal conduit. In general, the use of solid metal conduit is recommended as good wiring practice.

Figure 9  
Signal Wiring

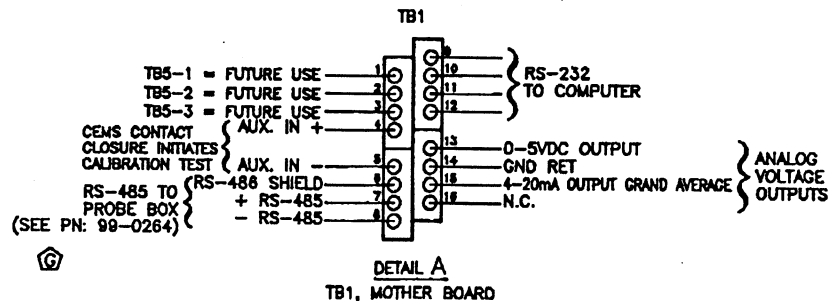

## Series 670 Digital Flow Averaging Array

Table 5  
Signal Wiring

Barrier Point #	Signal Name	Description
1	Aux RS-485 Gnd (3)	Shield for Computer Interface
2	Aux RS-485 (-) (3)	Computer Interface
3	Aux RS-485 (+) (3)	Computer Interface
4	Aux Analog In (2)	Auxiliary Analog Input
5	Aux Analog Gnd (2)	Auxiliary Analog Reference
6	RS-485 Shield (1)	Shield for Flow Meter Interface
7	RS-485 (+) (1)	Flow Meter Interface
8	RS-485 (-) (1)	Flow Meter Interface
9	Aux RS-232 Cntrl Out (3)	Computer Interface
10	Aux RS-232 Cntrl In (3)	Computer Interface
11	Aux RS-232 In (3)	Computer Interface
12	Aux RS-232 Out (3)	Computer Interface
13	Analog Volt Out (1)	0-5 VDC Output (Flow)
14	Analog Ground (1)	Analog Output Reference
15	Analog 4-20mA Out (1)	4-20mA Output (Flow)
16	Unused	

**Notes:**

- (1) Signals normally used.
- (2) Specials only.
- (3) Auxiliary computer interface (not Collector-Box or Collector-Box Emulator wiring).

Included with the Collector-Box is a standard EIA-485 (RS-485), serial, bi-directional interface. This interface allows up to ten Probe-Boxes (with up to eight sensor points per Probe Box) to be daisy chained on a single, twisted-pair plus shield cable. Maximum distance is 4,000 feet (1,200 meters) using 24-gauge, shielded, twisted-pair cable.

The wires for the Probe-Box RS-485 interface are connected to terminal strip TB1-7 and TB1-8, with the shield connected to TB1-6. Be careful to observe polarity, as shown in Figure 10 and Table 6, when connecting to pins 7(+) and 8(-).

**RS-485 8.4.1  
Interface to  
Probe-Boxes**

### 8.4.2 0-5 VDC and 4-20mA Output

The Collector-Box is equipped with 0-5 VDC and 4-20mA output signals. These signals usually represent the average of all Probe-Boxes connected to the RS-485 bus (Grand Average), but are selectable via <CONF.> to display individual probes or sensor points.

The full scale flow value (represented by 5 VDC and 20mA) may be modified via the <CONF.> setup procedure described in Section 9.2.6, *Digital to Analog Converter Full Scale*. Normally, it is equal to full scale multiplied by duct area.

The 0-5 VDC signal can drive a load resistance between 1,000 and 2,000 ohms and is output from "0-5VDC Output" (pin 13) and "GND RET" (pin 14). 0-1 and 0-10 VDC outputs are optional.

The 4-20mA signal can drive up to 10 volts (500 ohms) including drops in the wire and is output from "4-20mA Output" (pin 15) and "GND RET" (pin 14).

Whichever analog output signal you use, be sure to use "GND RET" (pin 14) for the signal return.

**Note:** This is not a loop powered device.

### 8.4.3 Relay Outputs

The Collector-Box is equipped with four relay outputs that are located above and below the main terminal barrier on the motherboard. (See Figure 10.) The relay outputs supply dry contacts and provide a Common, Normally Open, and Normally Closed circuit rated at 5A at 125/250 VAC and 0.5A at 24 VDC.

Figure 10  
Collector-Box Relay  
Outputs

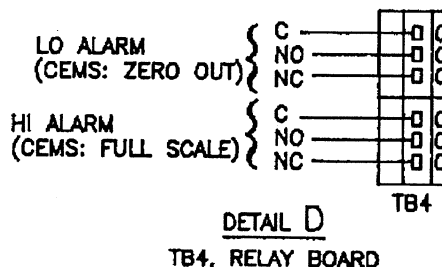
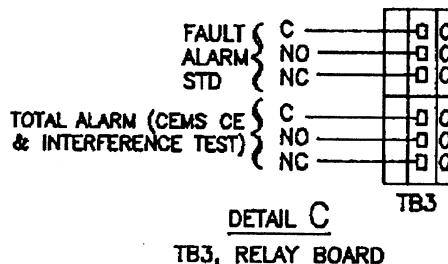

---

## Series 670 Digital Flow Averaging Array

---

The relays are energized when an alarm condition is active. In addition, the fault, low, and high flow alarm relays are latched. That is, they remain energized until the <ALARM ACKNOW.> button is pressed on the front panel.

**NOTE:** Normal relay operation is interrupted during a Calibration Error/Interference Test. Refer to Section 10, *Normal Operation*, for a detailed description of the relay operation during these tests..

Table 6  
Relay Board  
Terminal Assignments

Relay Name	Terminal Assignments			Relay Label
	COM <sup>1</sup>	NO <sup>1</sup>	NC <sup>1</sup>	
Fault Alarm	TB3-1	TB3-2	TB3-3	(K1)
Totalizer Alarm	TB3-4	TB3-5	TB3-6	(K2)
Low Flow Alarm	TB4-1	TB4-2	TB4-3	(K3)
High Flow Alarm	TB4-4	TB4-5	TB4-6	(K4)

**Note 1:** COM = Common, NO = Normally Open, NC = Normally Closed

---

**Series 670 Digital Flow Averaging Array**

---

---

## Series 670 Digital Flow Averaging Array

---

**CAUTION!** Before powering up everything for the first time, double-check all power and signal wiring.

**System Configuration** 9

**CAUTION!** After you have powered up for the first time, you must check the system configuration in either the Collector-Box or at one of the Probe-Boxes using the Collector-Box Emulator software. (See Appendix C, *Collector-Box Emulator Software*.)

After you have installed the probes, Probe-Boxes, and Collector-Box, completed the wiring between the probes and the Probe-Boxes, and established an RS-485 link between the Probe-Boxes and the Collector-Box, you are ready to power up the system.

**Powering Up the Collector-Box** 9.1

Power up the Probe-Boxes first, then power up the Collector-Box.

When you first power up the Collector-Box, it immediately goes into flow measuring mode. By default, the Collector-Box display panel shows Grand Average flow, and the LEDs reflect system status.

If you powered up the Collector-Box before you established an RS-485 link between it and the Probe-Boxes (or if you established the link but neglected to power up the Probe-Boxes), the Collector-Box will display zero flow and an RS-485 fault.

**NOTE:** The Collector-Box may be turned on or off independently of the Probe Boxes, and no damage will result.

**CAUTION!** You must verify the system configuration of the flow averaging array upon initial power up. It may be unnecessary for you to change anything (because the system is pre-configured during manufacturing), but you must verify the values against those shown in your approval drawings. In the future, you have to reconfigure the system only when some major change is made to the system. Once you configure the system, the data is stored in non-volatile memory that is retained for an unlimited period of time. The non-volatile memory does not depend on a back-up power source of any kind, not even a battery.

**Configuring the System** 9.2

When you press the <CONF.> button on the front panel, you will be shown a sequence of system parameters. As each parameter is shown, you will be asked to accept the previously stored value or to enter a new value. Refer to Section 9.3.1 for access code information.

If you press <YES>, the displayed value is accepted and the screen advances to the next parameter.

If you press <NO>, you will be prompted to enter a new value. Enter the new value by using the numeric keypad. To change one or more characters, use the <NO> key to backspace the cursor and delete the previously entered characters. When you have entered the desired value correctly, press <ENTER>. You will be asked to confirm the (new) value.

**NOTE:** Pressing the <ESC> button will get you out of most situations. If you press <ESC> after you are asked if you want to accept a value, the configuration program will abort and not store any of the newly entered values. If you press <ESC> after you are asked to enter a new value, the display will indicate "Try Again..." You'll then be returned to the previous screen. It's important that you go through the entire configuration procedure so the values you entered will be stored.

Also, if you do not take any action, after a period of time the display will "time-out" and you will be returned to normal operation without storing any new values.

At the end of the entire sequence of screens, all the new values will be stored in non-volatile memory.

The next sections contain step-by-step descriptions of the configuration parameters you will encounter.

### 9.2.1 Duct Area

The first screen you will see after pressing <CONF.> will ask you to verify the duct area. Press <YES> to accept the displayed value or <NO> to enter a new value.

The duct area is the cross-sectional area of the duct in which the Sierra probes are installed. See Section 11.1, *Flow Display*, for a detailed description of how flow rates are computed.

While viewing the duct area screen, pressing <CHANGE UNITS> will toggle the display between square feet and square meters.

*Recommended Value:* The cross-sectional area of the duct.

### 9.2.2 K-factor

The next screen displays the "K-factor." Press <YES> to accept the displayed value or <NO> to enter a new value.

"K-factor" is a dimensionless quantity used to modify the value of mass flow. It does not affect the velocity value and is included as a "compensation" or "bias" factor to provide flexibility in setting-up a system.

*Recommended Value:* 1 (no effect)

---

## Series 670 Digital Flow Averaging Array

---

The reference temperature is the temperature used to compute gas density and mass flow at a given reference temperature. Its value affects computed mass flow and "Standard" velocity. (Pressure is always referenced to one standard atmosphere). Sierra flow meters are calibrated using a reference temperature of 70°F.

**Reference Temperature** 9.2.3

If you select a reference temperature other than 70°F, the Collector-Box performs a conversion to your selected reference temperature based on Charles' law of ideal gas behavior. The Collector-Box allows you to select a value between 32°F and 100°F (0°C and 37.7°C). To enter a different reference temperature, press <NO>. To accept the displayed value, press <YES>. To toggle the display between degrees Centigrade and Fahrenheit, press <CHANGE UNITS>. If you do change the reference temperature, the gas density (next section) is also adjusted accordingly.

*Recommended Value:* 70°F. Sierra Instruments calibrates flow meters utilizing a reference temperature of 70°F. However, reference or "Standard" temperatures vary by industry and country.

The next screen displays gas density. It is mass per unit volume. By pressing <CHANGE UNITS> you may select between pounds per cubic foot (lbs/ft<sup>3</sup>) or grams per liter (gms/l).

**Gas Density** 9.2.4

Gas density is used to compute mass flow. See Section 10.1, *Flow Display*, for a description of the computations performed when calculating mass flow. To enter a new value, press <NO>. To accept the displayed value, press <YES>.

*Recommended Value:* Gas density of application gas at reference temperature. The default is for air: .07486 lbs/ft<sup>3</sup> (1.200 gms/l) at 70°F.

The Collector-Box generates two separate outputs you can choose from for use as inputs to a flow measurement control system: 0-5 VDC and 4-20mA. Normally, these outputs represent the average of all valid points in the system. However, you may choose to have the analog output represent the average measurement of a single probe (in a multiple probe system) or even a single point (in a multiple point probe).

**Analog Outputs** 9.2.5

To change the measured flow value, press <NO> or <FLOW> and the display will cycle through all individual probes and individual points in the system. To accept the displayed value, press <YES>.

*Recommended Value:* System Grand Average (average of all valid flow points in the system).

### 9.2.6 Digital to Analog Converter Full Scale

The value of DAC full scale ("DAC FS" on the LCD display) determines the flow value which will be represented by the 5 VDC analog output from the Collector-Box. It is normally the maximum Grand Average of all flow meters in the system. By pressing <CHANGE UNITS>, the value is cycled through all available flow units: SCFM, SCFH, SM3H, SFPM, SMPS, LB/H, LB/M, and KG/H.

The advantage of being able to program DAC FS is to "tweak" the full scale to exactly the value you want. This can be done in the field even if the desired value is finally determined after the system has been ordered, built, and installed.

For instance, assume that the originally specified full scale of the system (and consequently of the flow meters) is 43,000 SCFM. Setting the DAC full scale to 43,000 SCFM will result in a maximum output signal of 5 VDC at 43,000 SCFM.

If, after installation, you determine that 40,000 SCFM would be a better value (perhaps this is what the process computer being fed from the Collector-Box analog output signal expects), simply change the DAC FS to 40,000 SCFM and the Collector-Box will output 5.000 VDC at 40,000 SCFM.

The Collector-Box DAC full scale can be set to any desired value. However, it is unlikely that it will be useful to set it to a value very different from that of the Probe-Box(es). Setting DAC full scale to a value greater than the Probe-Box(es) full scale will result in the output (from the Collector-Box) never reaching 5 VDC. Setting it to a value less than the Probe-Box(es) full scale results in a loss of resolution.

*Recommended Value:* 100% of the Probe-Box(es) full scale, which is full scale velocity times the duct area. The full scale velocity and the duct area are programmed into the Collector-Box. You can verify the duct area by referring to the instructions in Section 10.2.1. You can verify the programmed, full scale velocity by pressing <\*> and then <9> and advancing the displayed values until the full scale velocity is displayed. (Probe-Box full scale is usually set to 30% greater than the specified maximum system flow).

### 9.2.7 High/Low Flow Alarm Setpoints (Optional)

If your Collector-Box has alarms, you can adjust the High and Low alarms in the same way. To accept the displayed value press <YES>; to enter a new value press <NO>.

By pressing <CHANGE UNITS>, the value is converted between all available flow units: SCFM, SCFH, SM3H, SFPM, SMPS, LB/H, LB/M, and KG/H.

*Recommended Value:* Zero to flow meter full scale.

---

## Series 670 Digital Flow Averaging Array

---

If your Collector-Box has a totalizer alarm, the setpoint (count up) will now be displayed.

**Totalizer Alarm  
Setpoint  
(Optional)** 9.2.8

The alarm setpoint is the value at which the totalizer alarm is activated. (See Section 10.2, *Totalizer*.) To accept the displayed value press **<YES>**; to enter a new value press **<NO>**.

The displayed value is shown in scientific notation, however, you can enter a new value in fixed point notation (i.e., just enter the desired value). The entered value will be shown in scientific notation and rounded to three decimal places. Internally, the value is stored in as accurate a form as possible (about .05% accuracy).

By pressing **<CHANGE UNITS>**, the value is converted between all available flow units: FT3, M3, LBS, and KG.

*Recommended Value:* Zero to 1 E+09 FT3 (2.831 E+07 M3)

Sierra Instruments Probe-Boxes constantly monitor their flow measuring circuitry for hardware faults. In the event of a hardware problem, this information is transmitted to the Collector-Box and the Collector-Box illuminates the Sensor Fault LED and activates the Fault Alarm.

**Programmable  
Kickout Flow** 9.2.9

Additionally, the Collector-Box may be programmed with a high and low flow “kickout” value for the system. What these two values represent is a “window” that defines a “good” velocity reading. If the flow value goes outside the window, the fault alarm is activated. The kickout window differs from the normal hardware monitoring of the flow measuring circuitry in that it can indicate a flow point fault even though the hardware is functioning correctly.

The main advantage of using the kickout feature is to detect problems relating to maintenance, such as plugging of sensors, rather than electronic failure. Its main disadvantage is that you run the risk of nuisance alarms.

*Recommended Value:* Do not use the kickout feature unless you are sure you will benefit from it. Try to set the window as wide as possible, taking into account the normal worst case flow variations in your system.

**9.2.10 Storing Setup and Checking Network**

At the end of the configuration process, you can store all the configuration parameters into the Collector-Box's non-volatile memory and watch as the flow network (every address on the RS-485 bus) is queried. When the Collector-Box reports the number of Probe-Boxes in the system, it must match the number that are physically present. Here are the screens you will see and a brief description of what the Collector-Box is doing:

Table 7  
Collector-Box Screens

Screen	Description
Storing Set-up. Please Wait...	All configuration parameters are being stored.
Checking Network. Please Wait...	Every address (1-32) is being queried.
D flow meters	Number of flow meters found. (D is an integer between 1 and 32.)
Set-up Complete	Final message before return to normal operation.

**9.3 Hidden Configuration Parameters**

**CAUTION!** Accessing hidden configuration parameters causes a re-count of the number of flow meters that define the system configuration. Be sure all flow meters are connected to the RS-485 bus, powered-up, and that at the end of the configuration procedure (Section 9.2.10), the same number of flow meters are shown on the display as are physically in the system.

It is normally unnecessary to access the hidden parameters. The only hidden parameter currently supported is the number of flow meters in the system. This is entered at the factory. It is only necessary to change this value if the number of flow meters in the system has changed, either by addition or deletion.

**9.3.1 Entering Setup Code and Storing System Configuration**

To access the hidden parameters, press **<CONF.>**, enter the "master" access code, 93924, and step through the configuration procedure described earlier. At the end of this procedure while the screen displays "Checking Network Please Wait...", press and hold **<\*>** on the front panel until "System Stored..." appears on the display. The addresses of all active flow meters that are on-line are now stored in non-volatile memory.

---

## Series 670 Digital Flow Averaging Array

---

The reason for storing the system configuration is so the Collector-Box will recognize which of the available addresses (1-32) are being used by your system. When a flow meter is off-line, the Collector-Box will be able to detect this condition and indicate a system fault.

You may enter your own personal access code by pressing <CONF.>, entering 93924, and pressing <ENTER>. While the screen displays "access accepted", press <\*> and you will be prompted to enter your own access code.

**Note:** The "master" access code of 93924 is always active.

Pressing the <DIAG.> button on the front panel causes the Collector-Box to run a diagnostic self-check of itself and to check that all flow meters are present on the RS-485 bus.

Diagnostics 9.4

After pressing <DIAG.>, you will see the message: "SIERRA Collector-Box" moving across the screen.

Then a series of self-check screens will appear. The first screen gives the version of the software. The second tests the LEDs. Then the keypad is tested.

Next, you will be asked if tests should be made which affect outputs. Press <YES> or <NO>. If you answer <YES>, the analog output (0-5 VDC and 4-20mA) is ramped up and down in a sawtooth waveform between zero and full scale for a brief period of time.

**CAUTION!** Choosing <YES> is not recommended if the Collector-Box is connected to a data acquisition system that would be affected adversely by this waveform event.

You will be asked if you want to test the relays. If you choose <YES>, the relays are energized and de-energized.

Following this, a number of internal checks are performed.

Finally, the network is inspected. If no faults in the flow measuring system are detected, the display will indicate this. If faults are detected, each fault is shown on the display. If there is more than one fault, each one is displayed sequentially.

For instance, if the flow meter at address 1 does not respond, the display will indicate: "Probe Box 1, RS-485 Fail."

If the flow meter at address 3 responds but has a bad sensor number 4, the display will indicate: "Probe Box 3, Sensor Fault 4."

If both of the above conditions exist at the same time, then the first message is shown for a few seconds, then the other message is shown.

---

## Series 670 Digital Flow Averaging Array

---

If you have kickouts programmed ON, then any sensors reading outside of the programmed kickout “window” will also be shown.

After the flow meters are checked, the Collector-Box automatically returns to normal operation.

**9.5 F1 Function Key** The F1 function key is not used in a standard Series 670 Digital Flow Averaging Array.

**9.6 F2 Function Key** If your Series 670 Digital Flow Averaging Array is being evaluated and compared to a standard calibration device such as an S-type Pitot tube and if the flow curve of the Sierra system differs from that of the calibration standard, you can use the Collector-Box’s K-factor option (see section 9.2.2) to make simple span adjustments to the flow curve of the Sierra system. Alternatively, you can use the <F2> function key to establish between 2 and 20 bias factors to fine-tune the Series 670 Digital Flow Averaging Array so its flow curve exactly matches the calibration standard.

**NOTE:** In order to establish correct bias factors, you must conduct a Relative Accuracy Test Audit (RATA). You will use the data from the RATA to create bias factors as described in the following procedure. The bias factors will remove irregularities that are the result of the RATA’s inability to represent flow repeatability in poor locations. The bias factors should be used only in cases where the flow is found to be very repeatable over the full range.

**9.6.1 Creating Bias Factors** To add bias factors to the configuration data stored in the memory of the Collector-Box:

- 1 Press <F2> twice. You will be prompted for your access code. (This is the same access code you use when configuring the system.)
- 2 Type in your access code and press <ENTER>.
- 3 When you are prompted with Bias Y/N, press <ENTER>.
- 4 When you are prompted whether you want to use previous Bias, press <NO>.
- 5 The system then asks how many bias factors you want to use. You can enter any number between 2 and 20. Increment the number of factors by pressing <YES>; decrement the number of factors by pressing <NO>. When the display indicates the number of bias factors you want to use, press <Enter>.

---

## Series 670 Digital Flow Averaging Array

---

- 6 When you are prompted for Ref Val 1, type the lowest reference value and press <ENTER>.
- 7 When you are prompted for Sierra No 1, type the lowest Sierra value and press <ENTER>.
- 8 Repeat steps 6 and 7 to add as many bias factors as you want to include in the system configuration.

**NOTE:** Enter the reference method values (Ref Val x) and Sierra Instrument equivalent values (Sierra No x) in sequential order beginning with the lowest values and progressing to the highest.

**NOTE:** If you make a mistake when entering a value, press <NO> to backspace over the incorrect value.

You can check the reference method and Sierra Instrument values after you have entered and saved the data in the memory of the Collector-Box. First, press <F2> once. Then press <YES> twice to see the first reference method value (RM1) and equivalent Sierra Instruments value (SI1). Continue to press <YES> to see subsequent combinations of reference method and Sierra Instrument values.

Checking the Bias Factors 9.6.2

**NOTE:** The first set of values (RM0 and SI0) will always be 0.

If you notice an error in any of the values, press <F2>. The Collector-Box will then put you at the beginning of the procedure for creating new bias factors (see section 9.6.1).

The <F3> key gives you the ability to look at the temperature (in degrees Centigrade) of:

F3 Function Key 9.7

- the entire system
- a single probe
- each individual sensor pair

This function key operates in exactly the same manner as the <FLOW> button on the front panel of the Collector-Box. If the system's grand average (of flow) is being displayed when you press <F3>, the display will change to indicate the average temperature of all the sensors in the system. If you continue to press <F3>, you will be able to see the average of each probe followed by the temperature of each point. You can leave this feature and resume looking at flow by pressing <FLOW>.

9.8 F4 Function Key

The <F4> function key provides you with the means to program individual K-factors for each sensor point in a flow averaging array. This feature is called SUB=SIERRA.

Although under normal circumstances this feature is not active (you could think of each sensor point as having a default K-factor of 1.0), when enabled SUB=SIERRA gives you the ability to create a special K-factor for those points that require modification.

For example, if a sensor point were defective or if it were positioned in an area of a duct that was very turbulent, the output from that sensor might be very high, very low, or swinging between the two extremes. The effect of this single point inaccuracy would be an inaccurate grand average output from the Collector-Box. The SUB=SIERRA feature gives you the ability to compensate for single point inaccuracies by allowing you to specify those points in need of correction and allowing you to calculate K-factors that will correct the outputs.

To activate the SUB=SIERRA feature, press <F4>. The display panel will ask whether you want to PRINT RATA. Press <NO>. The panel will then show you, by probe and point numbers, the SUB=SIERRA values that are currently in use by the Collector-Box. When this is complete, the display panel will ask you for your access code. Respond with "93924."

Next, the panel will ask whether you want the SUB=SIERRA feature to be enabled and whether you want to use previous values. If you answer <YES> (to enable) and <NO> (to using previous values), the display will list each sensor point in the array and ask you for new K-factors for each. You can input a value between 0.0 and 5.0. A value of 1.0 will not alter the output from a sensor point. Values less than 1.0 will decrease the output, while values greater than 1.0 will increase the output.

When you have finished supplying K-factors for each sensor point, the display will indicate :Storing Factors, Please Wait..."

You can turn the SUB=SIERRA feature on and off or change the K-factors for the individual sensor points at any time.

---

## Series 670 Digital Flow Averaging Array

---

**CAUTION!** Upon initial application of power, the flow measuring system must be configured. Refer to Section 9 for information on configuring the Collector-Box.

**Normal  
Operation** 10

When powered-up, the Collector-Box goes into normal operation. In this state, the display shows the flow rate in the engineering units that were in effect the last time the system was configured.

In the following sections, a detailed description of Collector-Box operation is given.

When you turn on the Collector-Box or press **<FLOW>** on the front panel, the average flow appears on the display.

**Flow Display** 10.1

By pressing **<CHANGE UNITS>**, the following units of flow measurement are cycled; SCFM, SCFH, SM3H, SFPM, SMPS, LB/M, LB/H, and KG/H. (See Table 9).

A brief description of system status such as "System OK" or "System Fault" also appears. The front panel LEDs work in conjunction with the display to alert you to any problems or alarms.

The Collector-Box continuously inspects the status of all sensors before it uses the data to calculate an average flow rate. If a defective sensor is detected and a fault is indicated on the front panel, the data from that point is not used in the final calculation. Only sensors that have been verified as functional are included in the flow average. Sensor inspection occurs 20 times/second.

Furthermore, a supervisory circuit continuously monitors the validity of the data. If any data is corrupted, the Collector-Box momentarily displays "RAM Access Denied."

Grand Average flow rate is based on all valid points in the system. However, by repeatedly pressing **<FLOW>**, you can observe the average flow through each probe and individual flow through each sensor on each probe. When a subset of flow measuring points is used to calculate an average (such as when you choose to look at the flow being measured by a single probe), this is indicated on the Collector-Box display. (This does not alter the output from the Collector-Box, however. Output is dependent on what you selected during configuration.)

For example, if you choose to observe the average flow (Grand Average) through all points in the system (and assuming no faults are detected), you would see: "AVG dddd.dd SCFM, System OK" (where d is a decimal digit between 0 and 9).

When you press **<FLOW>** for the first time, you would see: "PROBE 1 Average, dddd.dd SCFM."

When you press <FLOW> a second time, you would see; "Probe1 Point1, dddd.dd SCFM." Although flow rate for an entire duct is constantly measured, computed, and output from the Collector-Box, you have the ability to observe (1) total (Grand Average) flow in the duct, (2) average flow through all the points in a single probe, and (3) flow through a single point in a selected probe. By looking at individual probes and points, you can evaluate the flow profile of the duct.

### 10.1.1 How Flow is Computed and Displayed

There are three types of flow and eight different engineering units that may be selected via the <CHANGE UNITS> front panel button. The following section describes each one and how it is calculated.

- **Velocity** - The standard display is obtained by averaging all valid points in the system. The available engineering units are SFPM (Standard Feet Per Minute) and SMPS (Standard Meters Per Second).  $(\text{Velocity}) = (\text{Sum of all valid points}) / (\text{Number of valid points})$ . A K-factor, if one has been implemented in system configuration, is not applied.
- **Mass Flow** - Velocity multiplied by the duct area yields mass flow. Additionally, mass flow may be multiplied by a K-factor. The K-factor can be set to 1.000 (no effect) or to some other value to correct for system anomalies. Available engineering units are SCFM (Standard Cubic Feet per Minute), SCFH (Standard Cubic Feet per Hour), and SM3H (Standard Meters Cubed per Hour).  
 $(\text{Mass Flow}) = (\text{Velocity}) * (\text{Duct Area}) * (\text{K-Factor})$ .
- **Mass** - Mass flow can be further multiplied by the Gas Density to arrive at "true" mass flow. Available units for mass flow are LB/M (Pounds per Minute), LB/H (Pounds per Hour), and KG/H (Kilograms per Hour).  
 $(\text{Mass Flow}) = (\text{Flow}) * (\text{Gas Density})$ .

---

## Series 670 Digital Flow Averaging Array

---

a Kickout. (Refer to Section 9.2.9 for information about kickouts.) If the LCD is in a display mode that shows system status, a fault message will appear on the display.

All other alarms are optional. The high and low flow alarms are activated when the Grand Average flow rate is above or below the alarm setpoints, respectively. The totalizer alarm is activated when the totalized mass is above the alarm setpoint.

All alarms except totalizer must be continuously active for a period of time before the relay and LED are activated. This time delay is meant to reduce nuisance alarms.

By pressing **<ALARM>**, the setpoints for the low flow, high flow, and totalizer alarms are displayed (if these alarms are installed). The **<ALARM>** button displays only the alarms.

**Displaying Alarm Setpoints** 10.6

In order to adjust the alarm setpoints, you must configure the Collector-Box. This is achieved by pressing **<CONF.>** on the front panel and stepping through the configuration procedure until you are prompted for setpoint values. (See Section 9.2.7.)

The relay output marked "FAULT" is activated when there is a trouble condition. A trouble condition may be either an RS-485 Fault or a Sensor Fault. Assuming the display is showing system status, whenever a fault is detected the display reflects this immediately. If the fault persists for a short period of time, the relay and fault LED are activated.

**Relay Outputs** 10.7

There are three other relay outputs: Low Flow, High Flow, and Totalizer.

See Section 10.5 above for a detailed description of the alarm logic. See Section 8.4.3 for a description of where the relay terminals are located and how to wire to them.

---

**Series 670 Digital Flow Averaging Array**

---

## Series 670 Digital Flow Averaging Array

Table 8  
Flow Readout Options

Type of Flow	Units (<FLOW> button)
Velocity	SFPM, SMPS
Mass Flow	SCFM, SCFH, SM3H
Mass	LB/M, LB/H, KG/H

When you press <TOTAL> on the front panel, the display indicates accumulated mass and elapsed time in the following format: TO 1.234E+07 FT<sup>3</sup>, 12.345 Hours; where the total mass is displayed in scientific notation.

**Totalizer (Optional)** 10.2

“Overflow” occurs at 1.000 E+10 FT<sup>3</sup>. When the alarm value is reached or exceeded, the totalizer alarm is activated.

The totalizer is backed-up into non-volatile EPROM every ten minutes. This back-up preserves the totalized readings despite power interruptions and has an essentially unlimited storage time.

To reset the totalizer, press <\*> on the front panel, then press <TOTAL>. You will see the Reset Countdown on the display. By pressing <TOTAL> until the countdown reaches zero, the totalizer is reset to zero.

See Section 9.2.8 for information about setting the totalizer alarm setpoint.

The front panel status LEDs include Power, Sensor Fault, RS-485 Fault, High Alarm, Low Alarm, and Totalizer Alarm.

**Status LEDs** 10.3

- **Power** – This LED is illuminated when power is applied to the Collector-Box and the microprocessor is functioning.
- **Sensor Fault** – This LED is illuminated when a problem is detected by in the precision flow measuring circuits of one or more sensors. The Collector-Box does not include the flow data from these faulted sensors when it calculates average mass flow. Refer to Section 13, *Troubleshooting*, to correct sensor faults.
- **RS-485 Fault** – This LED is illuminated when one or more flow meters are not responding as expected on the RS-485 interface bus. Refer to Section 13, *Troubleshooting*, especially the information about the RS-485 interface bus.

- **High and Low Alarms** – These LEDs are illuminated when the measured flow is above/below the preset alarm setpoints, respectively. There is a built-in delay between detection of a High or Low Alarm and activation of the LED. Refer to Section 10.5, *System Alarms*.
- **Totalizer Alarm** – This LED is illuminated when the total mass flow has exceeded the alarm value. Refer to Section 10.5, *System Alarms*.

### 10.4 0-5 VDC and 4-20mA Output Signals

The Collector-Box is equipped with 0-5 VDC and 4-20mA output signals. These signals represent Grand Average flow rate as measured by all (functional) sensors reporting to the Collector-Box. The full scale value for this signal is programmable via the configuration procedure. Refer to Section 9.2, *Configuring the System*.

The Collector-Box has a **<FAST SLOW>** button that determines the speed of response of Grand Average flow reporting. By pressing and holding **<FAST SLOW>**, you can select how many readings are used to compute a Grand Average. The method used is commonly referred to as a “box car” filter. Normally when pressing **<FAST SLOW>**, an arrow indicates where the response speed is relative to the fastest and slowest setting. When the fastest or slowest setting has already been selected, the display shows a rectangular box so that you can more easily change the response.

### 10.5 System Alarms

There are four alarms on the Collector-Box: Fault, Low Flow, High Flow, and Totalizer.

Refer to Section 8.4.3 for a description of where the relay terminals are located and how they are wired.

Alarm logic is the same for all alarms. An alarm condition must be continuously present for a period of time before the corresponding alarm is activated. The alarm lights the front panel LED and activates the relay.

The alarm stays in effect regardless of whether the alarm condition persists until the front panel button **<ALARM ACKNOW.>** is pressed. If the alarm condition is no longer present, then **<ALARM ACKNOW.>** turns off both the LED and relay. If the alarm condition is still present, the relay is turned off and the LED continues to glow. If the alarm condition then disappears, the LED is extinguished.

The Fault Alarm is standard on every Collector-Box. It is activated whenever a fault condition is detected in the flow measurement system. This could be a Sensor Fault, an RS-485 Fault, or

---

## Series 670 Digital Flow Averaging Array

---

a Kickout. (Refer to Section 9.2.9 for information about kickouts.)  
If the LCD is in a display mode that shows system status, a fault message will appear on the display.

All other alarms are optional. The high and low flow alarms are activated when the Grand Average flow rate is above or below the alarm setpoints, respectively. The totalizer alarm is activated when the totalized mass is above the alarm setpoint.

All alarms except totalizer must be continuously active for a period of time before the relay and LED are activated. This time delay is meant to reduce nuisance alarms.

By pressing **<ALARM>**, the setpoints for the low flow, high flow, and totalizer alarms are displayed (if these alarms are installed). The **<ALARM>** button displays only the alarms.

**Displaying Alarm Setpoints** 10.6

In order to adjust the alarm setpoints, you must configure the Collector-Box. This is achieved by pressing **<CONF.>** on the front panel and stepping through the configuration procedure until you are prompted for setpoint values. (See Section 9.2.7.)

The relay output marked "FAULT" is activated when there is a trouble condition. A trouble condition may be either an RS-485 Fault or a Sensor Fault. Assuming the display is showing system status, whenever a fault is detected the display reflects this immediately. If the fault persists for a short period of time, the relay and fault LED are activated.

**Relay Outputs** 10.7

There are three other relay outputs: Low Flow, High Flow, and Totalizer.

See Section 10.5 above for a detailed description of the alarm logic. See Section 8.4.3 for a description of where the relay terminals are located and how to wire to them.



**WARNING!** Before opening the display panel of the Collector-Box, turn off mains power.

**Collector-Box Maintenance 11**

**CAUTION!** Changing the output signal from the Collector-Box, such as by adjustment of potentiometers or turning power off, may affect other plant equipment, alarm outputs, etc.

Refer to Section 14, Sierra Repair, if you need to return your Collector-Box to Sierra Instruments for repair.

Gaining access to the PCAs in the Collector-Box is a simple matter. First locate the black plastic latch on the left side of the display panel near the status LEDs. (See Figure 11.)

**Access to PCAs 11.1**

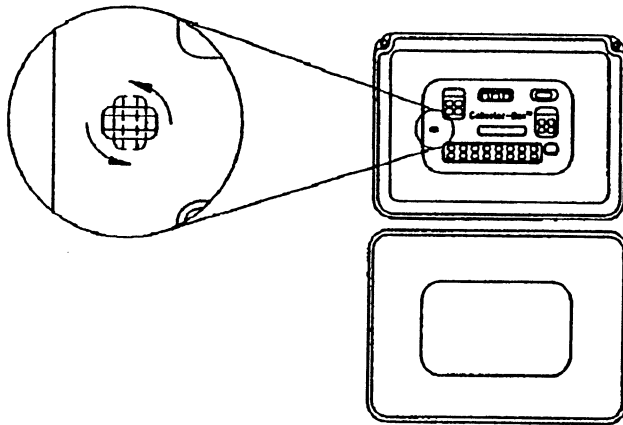

*Figure 11  
Locating the  
Collector-Box Latch*

Turn the slot in the latch to a vertical position to release the latch and open the display panel. (See Figure 12.)

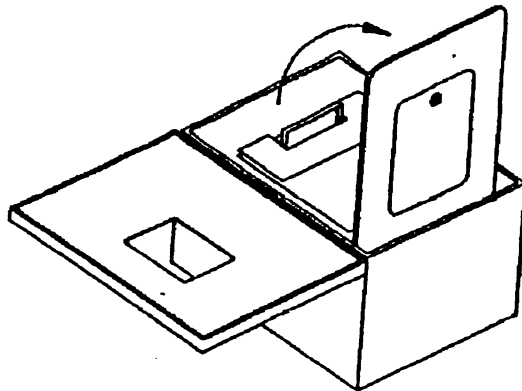
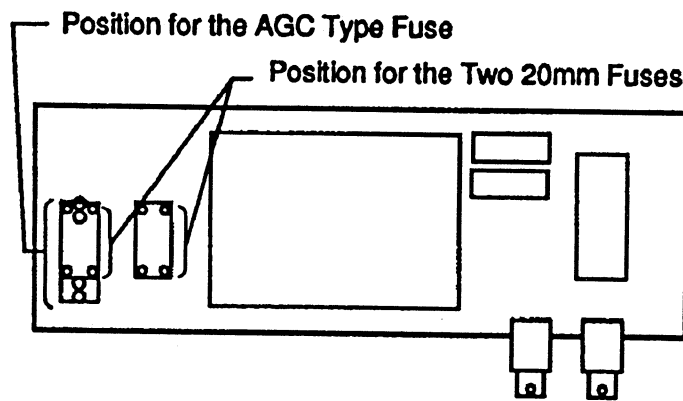

*Figure 12  
Releasing the  
Collector-Box Latch and  
Opening the Display Panel*

Release the latch and swing out the display panel. This exposes the motherboard, which contains all adjustment potentiometers, terminal strips including those for mains power, and alarm relay outputs. (See Appendix H for an illustration of Collector-Box motherboard component locations.)

The power supply board, which contains the fuses, is located beneath the motherboard on the bottom of the enclosure (see Figure 13).

Figure 13  
The Power Supply  
Fuses



The power supply board contains either one, 1A, AGC type fuse for 115 VAC power or two, 0.5A, 5 mm by 20 mm fuses for 230 VAC power. (See Figure 14.)

Figure 14  
115 VAC vs. 230 VAC  
Fuses

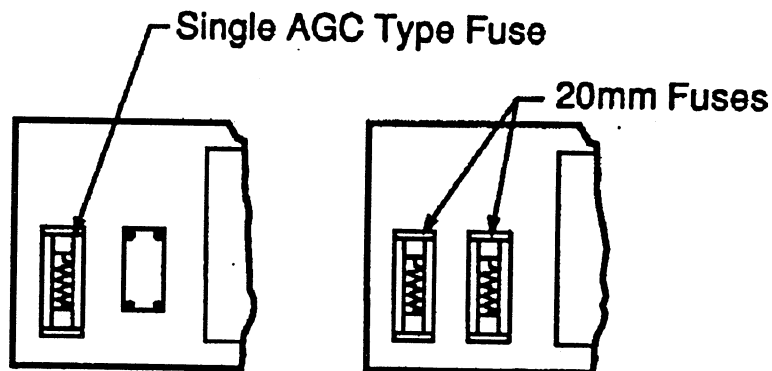

To ensure the continuing accuracy of your Series 670 Digital Flow Averaging Array, Sierra Instruments maintains a fully equipped, quality-controlled flow calibration metrology laboratory for re-calibration. If you have a probe, Probe-Box, or Collector-Box that has been damaged, or if you simply want to have your system re-calibrated, refer to Section 14 for information about contacting Sierra Instruments Customer Service Department.

The only field calibration adjustment that you may check is on the Collector-Box. This is the full scale for the output voltage (0-5 VDC). This is a very low drift precision circuit which normally does not need maintenance. To check the 0-5 VDC and 4-20mA outputs, press `<*>` and then `<4>` on the front panel. The Collector-Box first outputs zero and then full scale to both the voltage and current outputs. By adjusting potentiometer R39 on the Collector-Box motherboard, you can adjust the voltage output to its exact rated value. (See Appendix J for the location of this potentiometer.)



If you experience any problem with your Series 670 Flow Averaging Array, the solution is usually simple. This section helps you find that solution. If you cannot solve the problem yourself, please call Sierra's Customer Service Department. (See Section 14, Sierra Repair.)

- When you press **<DIAG.>**, the Collector-Box runs through a brief self-test of its electronics and then checks the flow meters which are supposed to be on-line. If no faults are detected in the entire system, this condition is noted on the display. Pressing any button causes normal operation to be resumed.
- The sensors, sensor-to-bridge board interface cables, bridge boards, Probe-Box, and Collector-Box are calibrated as a single, precision mass flow array. The sensors, sensor-to-bridge board interface cabling, and bridge boards are not interchangeable. Miswiring of cables or combining sensors with incorrect bridge boards will significantly affect the accuracy of the flow array.
- If an electronics or sensor fault is detected by the Collector-Box, Sensor Fault is indicated on the display and the LED is illuminated. This may indicate a failed bridge circuit or defective sensor. The probe indicating the sensor fault should be physically inspected.
- If a Probe-Box is not responding, an RS-485 fault is indicated on the display and the LED is illuminated. When this occurs, press **<CONF.>** and run through the sequence to the end. The number of Probe-Boxes in the network will then be displayed.
- If the number of Probe-Boxes appears as zero, the most likely problem is with the RS-485 cable. Check cable integrity throughout its entire length and verify that polarization has been observed on terminal strips. Ensure shielded cable is used. Also, ensure the RS-485 line is terminated (with a jumper on JB5) in the final Probe-Box on the RS-485 line. Finally, verify that no connections are made to other devices, such as a personal computer.
- The alarm relays are mounted on a PCA located on the motherboard and surrounding the main terminal strip. The entire relay PCA can be replaced in the field as a single unit.

If these suggestions do not relate to the problems you are having, refer to Table 9 for further help.

## Series 670 Digital Flow Averaging Array

Table 9  
Troubleshooting

Problem	Possible Cause	Action
Velocity measurement seems low.	Probe not oriented properly.	Orient probe with respect to flow.
	Probe dirty.	Refer to Section 7, System Maintenance, for information on cleaning probe.
Velocity measurement is erratic or fluctuating.	Very turbulent flow.	Try to find less turbulent area to measure velocity.
	Sensor dirty.	Refer to Section 7, System Maintenance, for information on cleaning probe.
	Sensor broken.	Refer to Section 14, Sierra Repair, to return probe to Sierra Instruments for repair.
	Probe not mounted securely.	Probe must be mounted securely without vibration.
	Malfunction in flow measurement circuitry.	Refer to Section 14, Sierra Repair, to return the Probe-Box to Sierra Instruments for repair.
Reading pegs plus or minus.	Sensor not connected to circuitry.	For external bridge or sensor, check wiring.
	Sensor is broken.	Refer to Section 14, Sierra Repair, to return probe to Sierra Instruments for repair.
Reading won't zero.	Out of Calibration.	Refer to Section 12, Calibration.
	Sensor broken.	Refer to Section 14, Sierra Repair.
4-20mA output not indicating 4mA at zero flow.	Excessive current loop resistance. Resistance must be between 250 and 600 ohms.	Use larger gauge wire or change load resistance.

---

## Series 670 Digital Flow Averaging Array

---

**Sierra Repair 14**

Probes, Probe-Boxes, and Collector-Boxes can be returned to the factory for repair or re-calibration. Call the Sierra Instruments Customer Service Department at (800) 866-0200 for information about returning equipment. Contact your sales representative for current pricing information for repairs and re-calibration.

If you call the Sierra Instruments Customer Service Department, please have your model number and serial numbers available when you call.

Please include information describing the reason for the return, purchase order number under which the equipment was purchased, and a contact name and phone number.

If you find it necessary to return all or part of a Series 670 Digital Flow Averaging Array to Sierra Instruments, you must first obtain an RMA (Return Materials Authorization) number from the Customer Service Department.

Unless specifically instructed to do otherwise, you must return the entire flow array, including all electronics.

Ship all equipment to the following address:

Sierra Instruments, Inc.  
5 Harris Court, Bldg. L  
Monterey, CA 93940  
ATTN: RMA #

Be sure to include complete return shipping instructions. We cannot deliver to post office boxes.

---

## Series 670 Digital Flow Averaging Array

---

## Series 670 Digital Flow Averaging Array

## Specifications A

Table 10  
System Specifications

<b>Flow Ranges</b>	0-1,000 SFPM to 0-15,000 SFPM or 0-0.5 SMPS to 0-75 SMPS
<b>Gases</b>	Air, nitrogen, argon, helium, natural gas; consult the factory for other.
<b>Flow Output Signals</b>	For Probe-Box and Collector-Box: two standard analog output signals linearly proportional to array average (of probe or array) mass flow rate or velocity; 0-5 VDC standard, 1000 ohms minimum load resistance; 4-20mA standard, 600 ohms maximum loop resistance; 0-1 VDC optional, 200 ohms minimum load resistance; or 10 VDC optional, 2000 ohms minimum load resistance.
	RS-485, serialized output standard linearly proportional to array average mass flow rate or velocity and individual point velocities; 2-wire, shielded cable, 4000 feet (1200 meters) maximum length, daisy-chained hook-up.
	<b>Note:</b> This is not a loop powered device.
	<b>Note:</b> Other output signals available on special order.
<b>Temperature Output Signals</b>	For Probe-Box: for each Digi-Bridge/sensor point, in degrees C; for the Probe-Box as a Grand Average, in degrees C.
	For Collector-Box: for the entire array as a Grand Average, in degrees C; for each probe as an average of all sensor points on that probe, in degrees C; for each sensor point, in degrees C.
<b>Totalizer</b>	For Collector-Box: 8 digits count-up or count-down, on the 32 character alphanumeric display, specify count-down initial value.
<b>Alarms</b>	For Probe-Box and Collector-Box electronics: high flow; low flow; and "window" flow rate alarms; totalizer alarms; totalizer alarm dry contact outputs; specify levels.
<b>Digital Readout</b>	For Collector-Box: alphanumeric LCD 32 characters, on two lines, in any engineering units; 4-1/2 digits for mass flow and velocity in any engineering units; 8 digits for totalizer; also displays individual point velocities for all points in the array; self-diagnostic checks; configuration status and prompts.
<b>LED Indicators</b>	For Probe-Box: Aux, Version, Over-Range, Full Scale, Zero, Power On (all on the Controller board) and (8) Bridge On (on the motherboard).
	For Collector-Box: Power On, Fault, Totalizer, Low Flow, and High Flow.

---

## Series 670 Digital Flow Averaging Array

---

<b>Input Power Required</b>	Probe-Box: 115 VAC ( $\pm 10\%$ ), 60 Hz, 2.5 W base, 5 W per point standard; 230 VAC ( $\pm 10\%$ ), 50 Hz, 2.5 W base, 5 W per point optional; 20-26 VDC, 50mA base, 250mA per point optional; 100 VAC ( $\pm 10\%$ )50 Hz, 2.5 W base, 5 W per point optional.
	Collector-Box: 115 VAC ( $\pm 10\%$ ), 60 Hz, 12 W; 100 VAC ( $\pm 10\%$ ) standard; 115 VAC ( $\pm 10\%$ ), 50 Hz, 12 W optional; or 230 VAC ( $\pm 10\%$ ), 50 Hz, 12 W optional.
<b>Number Of Point Velocities</b>	Ten daisy-chained Probe-Boxes, eight sensor points maximum per Probe-Box.

It is not necessary for you to know the details of the RS-485 protocol if you are using a Collector-Box or Collector-Box Emulator software. This description of Sierra's RS-485 protocol is provided mainly for reference, although you may, if you choose to, write your own software driver for an RS-485 equipped computer.

The RS-485 interface standard is a hardware standard only. It is based on the industry standard 8051, 8251, 16450, 16550 and other, similar, integrated circuits. Sierra Instruments has implemented a software protocol in order to use the interface specifically for its own Probe-Boxes. According to this protocol, there is one "master" transceiver (Collector-Box or PC-compatible computer) and may be up to 30 "slave" transceivers (Probe-Boxes) in a system.

The data format is 11 bits: one start bit, eight data bits (MSB first), a "parity" bit that is used to determine if the information is "data" or an "address," and a stop bit. This is very similar to the RS-232 standard in which the format *9600,n,8,1* indicates that "9600" is the baud rate, "n" means no parity (it could be "o" for odd parity or "e" for even parity), "8" means eight data bits, and "1" means one stop bit.

A common question is why Sierra uses eleven bits when most programmers use ten. In actuality, most programmers do use eleven bits because the parity bit has been assumed to be "n" (none). So the parity bit, which has been ignored and not sent, is now toggled by the electronics to detect whether information is data or an address.

Remember, the RS-485 interface is bi-directional, so you must control the transmission direction of the master (the Collector-Box or Collector-Box Emulator). Slaves (Probe-Boxes) are always receiving, unless specifically addressed by the master.

To initiate a data exchange, the master transmits an address (1-32) with the tenth "parity" bit equal to one. At all other times the tenth bit is zero. This causes all Probe-Boxes to be interrupted. They inspect the received address to see if it matches their own address. If it doesn't, they take no action but resume normal processing. If a match is detected, the Probe-Box responds with a transmission that occurs within the next 100 milliseconds. Refer to Table 11 for a complete description of all bytes transmitted from the addressed slave (Probe-Box).

## Series 670 Digital Flow Averaging Array

Table 11  
RS-485 Interface,  
REV. 1.02

Byte Number	Description
1	Probe-Box Address Echo; Value: 1-30
2	Probe-Box Type; Value: 1 = Single Point, 2 = Multi-Point
3, 4	Probe-Box Software Version; Value: 0-65,535, 100 = Version 1.00, 250 = Version 2.50, etc.
5	Number of Points; Value: 1 = 1 Point, 2 = 2 Points, etc.
6	Units English/Metric; Value: 0 = SMPS/deg C, 1 = SFPM/deg F
7, 8	Full-scale value; Value = 0-65,535 = 0-65,535 SMPS or SFPM depending on units specified by customer
9, 10	Low Alarm Setpoint, Local (Probe-Box Only) Low Alarm; Value = 0-65,535
11, 12	High Alarm Setpoint, Local (Probe-Box Only) High Alarm; Value = 0-65,535
13	Probe-Box Supply Voltage; Value = 0-255 = 0 to 25.5 volts
14	Speed of Response. Proportionate to response speed of output signal from Probe-Box; Value = 1-255. 1 = fast, 255 = slow
15, 16	Alarm Status Flags; Value = Alarms ON/OFF flags
17, 18	Fault Status Flags; Value = Faults ON/OFF flags
19, 20	Temperature Value; Value = 0-65,535
21, 22	Average Flow Value; Value = 0-65,535
23-38	Individual Point Flow Value. Points 1-8, each reading; Value = 0-65,535. Unused points, Value = 0
39-48	Spare. All bytes; Value = 0
49, 50	Checksum. Binary sum of all transmitted bytes including address.

**Note:** All numbers transmitted represent unsigned binary numbers unless noted. For 2-byte numbers, transmission is MSB first, then LSB. Contact Sierra applications engineers for the latest release version.

**NOTE:** You cannot use a Collector-Box and the Collector-Box Emulator software simultaneously. The Collector-Box can be connected to the flow array, but it must be turned off when you are monitoring flow with your personal computer.

One of the major benefits of the Series 670 Digital Flow Averaging Array is the provision for an operator to monitor complete system configuration and flow using an IBM-compatible computer running Sierra Instruments Collector-Box Emulator software. Although a standard Collector-Box allows you to monitor flow, the emulator software allows you to view flow and temperature of all points in the system simultaneously.

Furthermore, your personal computer can be connected to the flow averaging array at any of several points. If the system contains more than one Probe-Box, the computer can be connected to any one of them and the entire system still can be monitored. Because the interface between the flow averaging array and the computer are via an RS-485 interface, you do not even have to be close to the device you want to monitor. 4000 feet of shielded, two conductor, cable can separate you and your computer from the Probe- or Collector-Box once you have established the physical connection.

Finally, because all Probe-Box electronics in Series 670 Digital Flow Averaging Arrays are software-based, you also can use your personal computer to upgrade the software whenever enhancements are available by Sierra Instruments.

All of these benefits make use of the menu-driven Collector-Box Emulator software not only a tremendous engineering achievement, but an operator's delight.

In order to make use of the Collector-Box Emulator software, you must have an IBM-compatible computer (XT or more recent) with 640K of RAM (or more) and an EGA, VGA, or Hercules-compatible monitor. The computer can be either a desktop or laptop model, and you will need to establish an RS-485 link between the computer and your Series 670 Digital Flow Averaging Array. You can accomplish this in two ways.

If you are going to use a desk-top, rather than a laptop, computer, you can obtain an RS-485 interface card from Sierra Instruments. (Contact your Sierra sales representative for further information.) This interface card is a standard IBM-compatible device that can be plugged into any 8-bit or 16-bit bus slot in your computer. Instructions for installing and connecting the card are supplied with the device.

### Hardware Requirements

### RS-485 Interface Card

---

## Series 670 Digital Flow Averaging Array

---

### RS-485 Interface Adapter

The second way of interfacing your computer with your Series 670 Digital Flow Averaging Array is with an RS485 interface adapter, also available from Sierra Instruments or from Telebyte Technology, Inc. (You can reach them at 1-800-835-3298. Order their Model 266F.)

You can plug this adapter into your computer's 25-pin serial port (or 9-pin serial port, if you use an adapter)—and configure the port as either COM1 or COM2.

You can use this adapter equally well with either a desk-top or lap-top computer. Instruction for installing and connecting this type of adapter are shown in Figures 15 and 16.

Figure 15  
RS-485 Interface  
Adapter Using 25-pin  
D Shell Serial Port

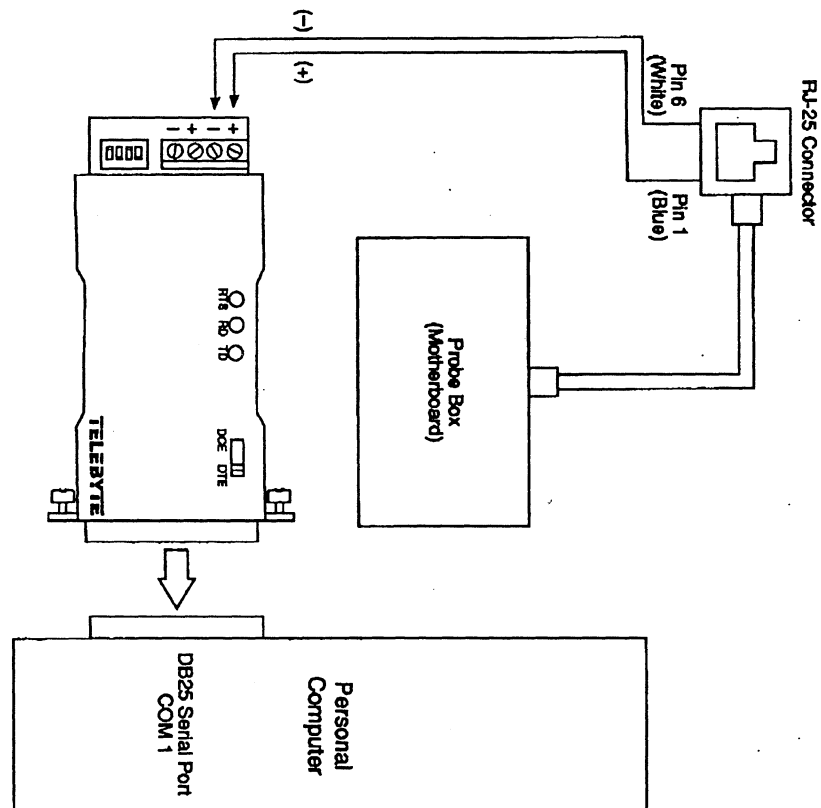

---

## Series 670 Digital Flow Averaging Array

---

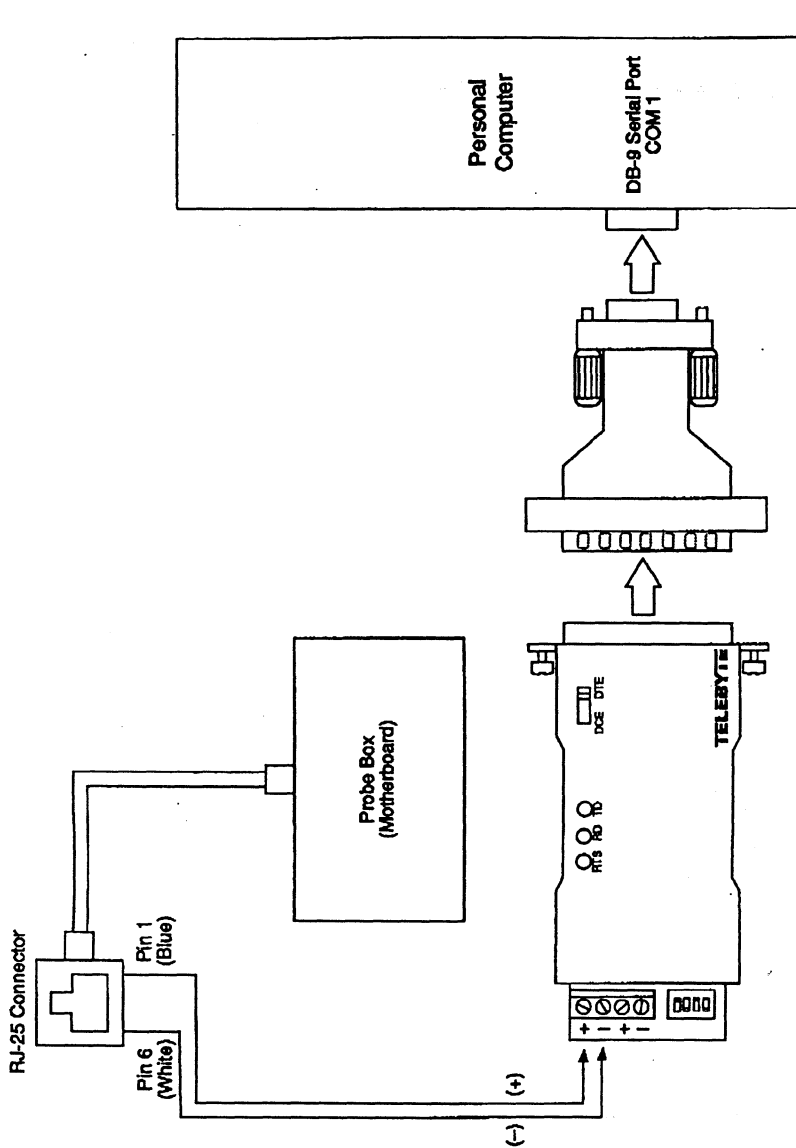

Figure 16  
RS-485 Interface Adapter  
Using 9-pin D Shell Serial  
Port

You may make final connection between your personal computer and the Series 670 Digital Flow Averaging Array at the RS-485 connector on the motherboard in any one of the Probe-Boxes. (See Appendix G, Probe-Box Motherboard Critical Component Locations, for location of the RS-485 connector.)

The menu-driven Collector-Box Emulator software is available from Sierra Instruments in two formats—5.25" high-density diskette and 3.5" high-density disk. When placing your order with Sierra Instruments, please specify which format you desire.

### Installing the Software

When you receive the diskette:

- 1 Create a subdirectory on your hard disk drive called DIGSIER.
- 2 Insert the Sierra diskette into the appropriate diskette drive in your computer.
- 3 Log onto that drive, and copy all the files from the diskette to the DIGSIER subdirectory.
- 4 When the copying process is complete, store the diskette in a safe place.

### Using the Software

Log onto the DIGSIER subdirectory, and type **DIGSIER** <Enter>. The following information will appear on your screen:

Figure 17  
Main Menu

```
TEST MODE WITHOUT RS-485 BOARD
Address No: TEST Bridge No. TEST, Digi-Bridge Software Rev. No: TEST
SIERRA INSTRUMENTS CEMS INTERFACE PROGRAM REV 1.58

8/27/1993

P. PC Collector Box
T. Toggle Test Mode
S. Select new Address
Q. Quit

ENTER Your Selection Now
```

### Main Menu Options

You have four options from the main menu:

- **Option P**—to use the Collector-Box Emulator software in TEST mode or MONITOR mode
- **Option T**—to select between TEST mode and MONITOR mode
- **Option S**—to select a specific Probe-Box and Digi-Bridge board from which to monitor the flow averaging array
- **Option Q**—to quit using the emulator software

---

## Series 670 Digital Flow Averaging Array

---

When you first run the Emulator software and are presented with the main menu, the Emulator will be in TEST mode. You can verify this by looking near the top of the main menu. Address No., Bridge No., and Software Rev. No. all indicate TEST mode. (Look closely at Figure 17.) In order to select MONITOR mode and see valid data from your flow averaging array, you must toggle (quit) out of TEST mode and enter MONITOR mode. We recommend you use TEST mode for training purposes.

Press <T> to toggle between TEST mode and MONITOR mode. You can use the default Probe-Box and Digi-Bridge (sensor point) addresses (Probe-Box #1 and sensor point #1) or you can select any valid address in the system. (You can determine the address of a Probe-Box by looking at jumper block JB1, RS-485 Probe Box Address.)

**NOTE:** If you attempt to toggle between TEST mode and MONITOR mode under the following conditions, an error screen (Figure 19) will appear:

- the Collector-Box is powered up
- the computer is not connected correctly to an RS-485 port in the flow averaging array
- the RS-485 adapter is not powered up
- there is a problem with the RS-485 adapter
- the flow averaging array is turned off

**NOTE:** When using Collector-Box Emulator software, the Collector-Box, if there is one in the system, must be turned off.

### Menu Option T

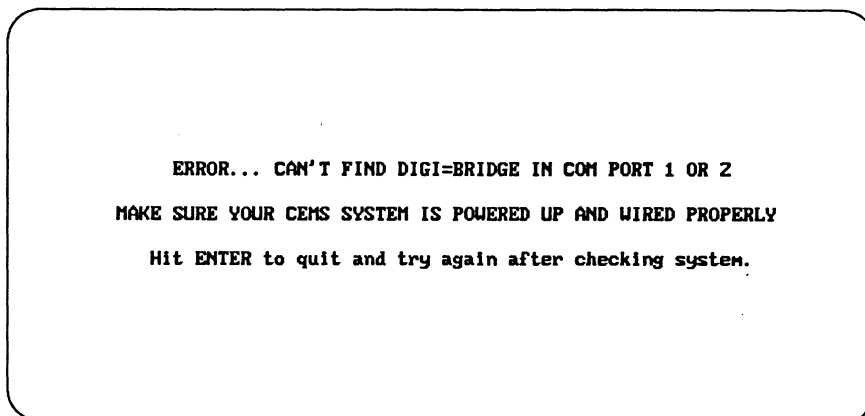

*Figure 18*  
*Error Screen*

### Menu Option P

If you select the main menu option P and if you have met all the hardware installation criteria for the Collector-Box Emulator, you will see the PC Collector Box screen. See Figure 19.

**NOTE:** If you select Option P and you see the error screen shown in Figure 18, go back to the section, *Menu Option T*, and verify that none of the conditions listed is taking place.

Figure 19  
PC Collector-Box  
Menu

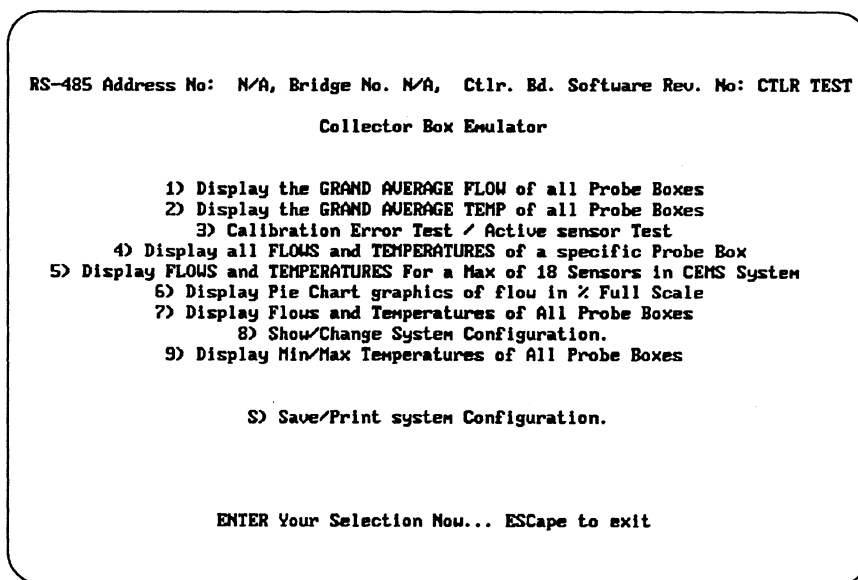

You can select any of the options from the Collector-Box Emulator menu, but before you do, observe the following note.

**NOTE:** The upper right-hand corner of the Collector-Box Emulator menu indicates either:

- the version of the software in use or
- the emulator is in TEST mode

If you access this menu without first toggling out of TEST mode in the main menu, the data you see will be invalid. (In TEST mode, the data shown is sample data built into the software to demonstrate the software.) *Verify that you are in monitor mode if you want to see valid flow data!*

The PC Collector-Box menu provides you with ten options. Although the options are self-explanatory, a description of each follows:

- 1     **Display the GRAND AVERAGE FLOW of all Probe-Boxes**—As the option says, you will be shown the Grand Average of all the Probe-Boxes. You also will be shown the average flow of each Probe-Box. The average flow of each Probe-Box is calculated by summing the flows of all working sensor points related to a specific Probe-Box and dividing by the number of sensor points. The Grand Average of all the Probe-Boxes is calculated by summing the average flow of all the Probe-Boxes and dividing by the number of Probe-Boxes.
- 2     **Display the GRAND AVERAGE TEMP of all Probe-Boxes**—This option is identical to Option #1 except that temperatures are displayed rather than flow. Calculations are performed in the same manner.
- 3     **Calibration Error Test / Active Sensor Test**—This feature is not normally used with a standard Series 670 Digital Flow Averaging Array.
- 4     **Display all FLOWS and TEMPERATURES of a specific Probe-Box**—You can use this option to view the flows and temperatures of all sensor points related to a specific Probe-Box. Before you are shown any data, you will be asked to specify a Probe-Box address.
- 5     **Display FLOWS and TEMPERATURES for a maximum of 20 Sensors**—This option uses two different screens to display flows and temperatures. The first screen shows you numerical values for all the temperatures and flows in a Series 670 Digital Flow Averaging Array comprising no more than twenty sensor points. A second screen provides you with a pie chart graphical representation of the flow at each sensor point.
- 6     **Display Pie Chart Graphics of Flow in % Full Scale**—This option uses the same pie chart graphic to show you the flow through each point in a flow array of no more than twenty sensor points.

- 7 Display Flows and Temperatures of all Probe-Boxes**—This option is similar to Option #4 in that it shows you the flows and temperatures of sensor points related to specific Probe-Boxes. But instead of showing you the data for a single Probe-Box, this menu option cycles through the entire flow array one Probe-Box at a time, showing you the flow and temperature for every sensor point in the system.
- 8 Show / Change System Configuration**—This option permits you to view and change the system configuration information that is stored in a specific Probe-Box. Unlike the system configuration stored in the Collector-Box, which contains data pertaining to the entire flow array, the Probe-Box-specific system configuration shown here is what the Probe-Box that you have selected understands the system configuration to be. Normally, most parts of the system configuration will be the same in the Collector-Box and all Probe-Boxes that are part of a single flow array. (The default address, Probe-Box #1, automatically reflects the system configuration that is stored in the Collector-Box.)

**NOTE:** Item #7, the Auto-Self Clean starting time, should be different (by at least 10 minutes) in each Probe-Box that is part of a single flow array. All other items, #1 through #6, should be identical in the Collector-Box and all Probe Boxes. The only time this would not be the case would be in a system in which Probe-Boxes are connected to sensors that monitor flow in different ducts and yet feed a common Collector-Box. In this unusual circumstance, duct area and full scale flow could be different from one Probe-Box to another.

- 9 Display Minimum / Maximum Temperatures of all Probe-Boxes**—This option maintains a running record, which is updated every minute or so, of the minimum and maximum temperatures that each sensor point is subjected to over the life of its installation. Like Option #7, this menu option cycles through the entire flow array one Probe-Box at a time, showing you minimum and maximum temperatures for each sensor point in the system.
- S Save / Print System Configuration**—This option allows you *to save* the system configuration information to a disk file or *to send* the same information to a printer. Part of the system configuration that is saved to a disk file (or sent to a printer) includes the “personality” for each sensor point in the flow array.

---

## Series 670 Digital Flow Averaging Array

---

**NOTE:** If you are going to experiment with a Probe-Box's configuration information for any reason, this option is useful because it allows you to save the old data to a file for safekeeping, just in case you might want to use it again.

This main menu option allows you to select a specific Probe-Box and Bridge (sensor point) address from which to monitor system flow or temperature. The default values are Probe-Box #1 and Bridge address #1.

**Menu Option S**

This main menu option allows you to quit from the Collector-Box Emulator software program.

**Menu Option Q**

Sierra Instruments is constantly revising the Collector-Box Emulator software in an effort to refine and expand the program's capabilities and its ease of use. As new versions of the software become available, Sierra Instruments distributes them on an "as needed" basis. That is, if the changes made simply enhance product performance or capability, Sierra will not send new versions of the software to all its customers. If, on the other hand, a change eliminates a potential source of problems with the product, Sierra will distribute new software to all affected customers.

**Upgrading the Software**

The Collector-Box Emulator software is composed of three files:

**Parts of the Emulator Software**

- **DIGSIER.EXE**—this portion of the software is responsible for collecting and analyzing the data from the Probe-Boxes and displaying that information on your screen.
- **EGAVGA.BGI**—this is an EGA/VGA graphics screen driver for the program
- **HERC.BG1**—this is a Hercules graphics screen driver for the program

If you receive a new version of the software from Sierra Instruments, review any special instructions included with the diskette. If the software includes an upgrade to the Controller board or Digi-Bridge microprocessor software, see the section called, *Upgrading the Microprocessor Software*.

If a software upgrade involves only a change to the Collector-Box Emulator software, you can copy the new file(s) directly from the upgrade diskette to the hard disk drive in your computer.

### Parts of the Microprocessor Software

The microprocessor software for the Digi-Bridge and Controller boards is composed of two files:

**651vXX.CMD**—this is the portion of the software that is resident in the controller board in each Probe-Box.

**DIGIvXX.CMD**—this is the portion of the software that is resident in each Digi-Bridge board in a Probe-Box.

### Upgrading the Microprocessor Software

If a software upgrade affects the software stored in the microprocessors of the Controller or Digi-Bridge boards, you will need to obtain a special adapter from Sierra Instruments Customer Service. This adapter allows your computer to communicate with a Series 670 Digital Flow Averaging Array via an RS-232 communications link. Figure 20 illustrates the RS-232 adapter and shows you how to install it to complete the communications link.

Figure 20  
RS-232  
Communications  
Adapter

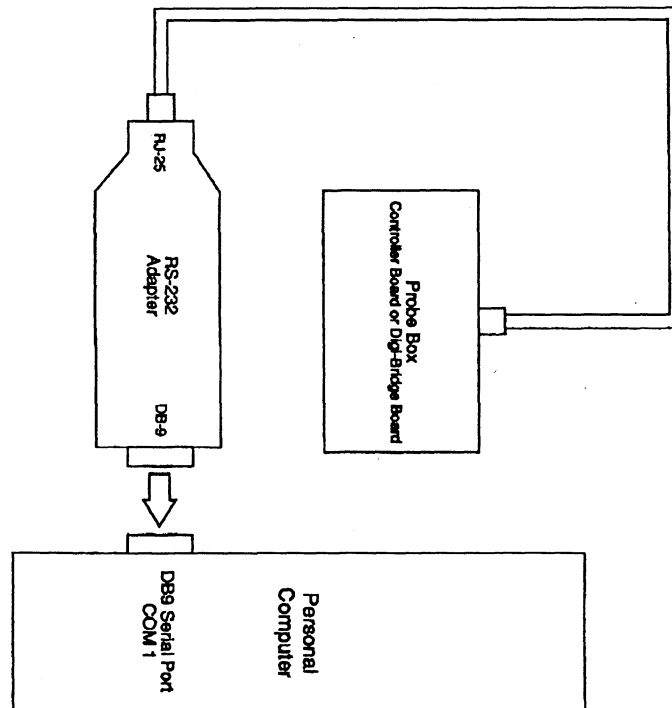

---

## Series 670 Digital Flow Averaging Array

---

Each Controller board and Digi-Bridge board contains a dual-mode, RJ-25 communications connector. This connector can be used in two modes:

### Communications Mode Selection

- a default, operational, RS-485 MODE to monitor flow
- a temporary RS-232 MODE to upgrade the software stored in a microprocessor's memory

A mini-jumper next to the RJ-25 connector determines the connector's mode. See Figures 21 and 22 for the locations of the RJ-25 connectors and mode-select mini-jumpers on the Controller board and Digi-Bridge board.

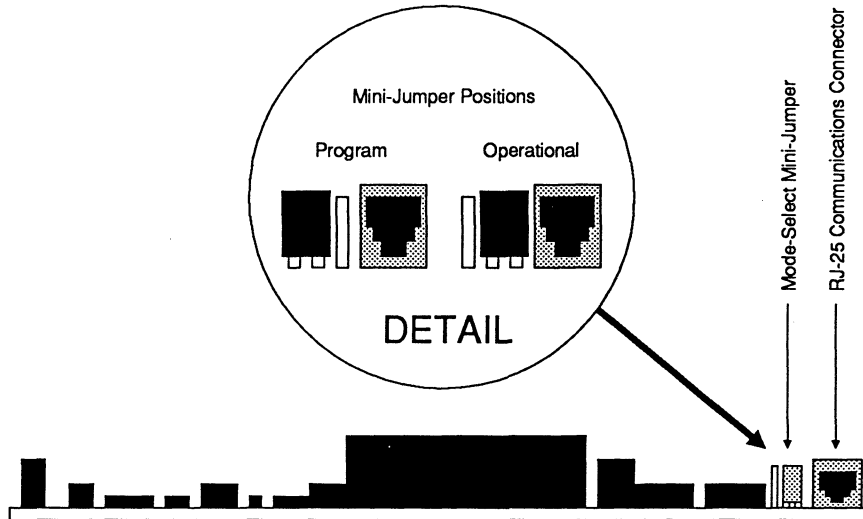

Figure 21  
Controller Board  
Communications  
Connector and  
Mini-Jumper

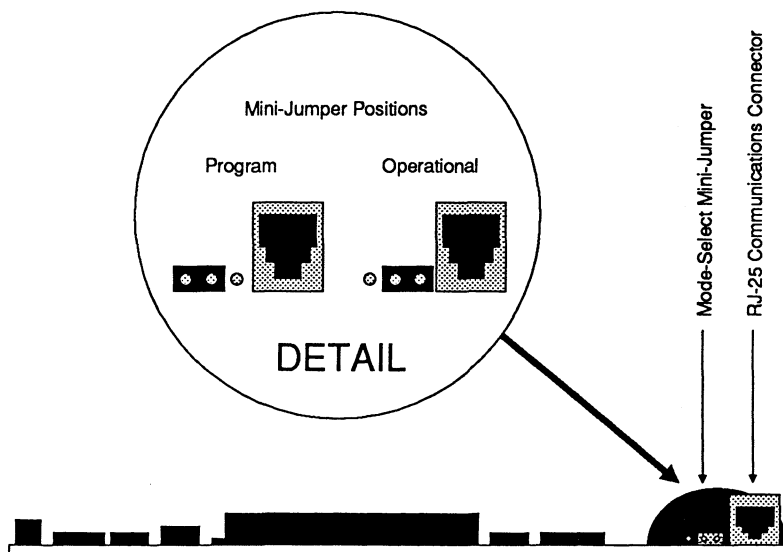

Figure 22  
Digi-Bridge Board  
Communications  
Connector and  
Mini-Jumper

---

## Series 670 Digital Flow Averaging Array

---

In order to use the RJ-25 connector to upgrade the software in the Controller or Digi-Bridge boards, you must move the mini-jumper to its RS-232 MODE position. After following the installation instructions included with the software upgrade diskette, return the mode-select mini-jumper to its original, default, operational, RS-485 MODE position.

After you have completed the software installation, double-check the positions of the mode-select mini-jumpers and store the upgrade diskette in a safe place.

---

## Series 670 Digital Flow Averaging Array

---

### Controller Board LEDs

D

The Controller board contains six LEDs arranged along the top edge of the circuit board. These LEDs provide operational and diagnostic information about the state of the Controller board and the Digi-Bridge boards with which it communicates.

Frequently the LEDs' states, on—off—blinking, are determined by whether the operator has pressed Controller board pushbutton switch, SW1, to generate a series of calibration voltages. (See Section 4, *Operating Instructions*, for an explanation on the use of this switch and its affect on the LEDs.)

The LEDs are numbered CR1 through CR5 and CR11, with CR1 being the LED closest to the edge of the circuit board. (See Appendix F, *Controller Board Critical Component Locations*, for an illustration of the LEDs.) An explanation of the LEDs' states follows:

- CR1 **POWER**—always on solid whenever the Probe-Box is turned on.
- CR2 **ZERO (yellow)**—normally blinks when the Probe-Box is connected via RS-485 to a Collector-Box to indicate the health of the Controller board's microprocessor; blinks more slowly when the Probe-Box is connected via RS-485 to an IBM-compatible computer running Collector-Box Emulator software; on solid when SW1 forces generation of 0% DAC FS output.
- CR3 **FULL SCALE (yellow)**—on solid when SW1 forces generation of 100% DAC FS output. (CR3 and CR2 are on solid when SW1 forces generation of 25%, 50%, and 75% DAC FS output.)
- CR11 **OVER-RANGE (green)**—normally on solid to indicate the Digi-Bridge interface with the Controller board is working correctly; blinks slowly if there is a problem.
- CR4 **VER (green)**—on solid during Auto-Self Clean; blinks the software version number when SW1 forces generation of 100% DAC FS output (v2.32=6 blinks, v2.2=5 blinks, v2.0=3 blinks, v1.9=2 blinks, v1.8=1 blink)
- CR5 **AUX (green)**—blinks to indicate when the Controller board is communicating with a Collector-Box; on solid when the Controller board is communicating with an IBM-compatible computer running Collector-Box Emulator software.

---

**Series 670 Digital Flow Averaging Array**

---

<b>A</b>	
access code	37, 42
air mass velocity	3
alarm relays	57
alarm,	
fault	50
high and low flow	51
setpoints	51
alarms	61
alarms,	
system	50
Auto-Self Clean	5 - 6, 72
<b>B</b>	
back-up battery,	
totalizer	25
bias factors	44 - 45
<b>C</b>	
calibration	55
CE Test	71
centroid (of equal areas)	6, 19
Collector-Box Emulator	15, 29, 63, 65, 67 - 70, 73, 77
Collector-Box,	
access code	43
alarm setpoints	40 - 41
analog outputs	39
diagnostics	43
fuses	54
hidden configuration parameters	42
input power	31
installation	31
kickouts	41
maintenance	53
mounting	31
operator buttons	1
output signals	34, 50
relay outputs	34
storing setup	42
viewing angle	31
computer,	
IBM-compatible	15, 65
configuration,	
system	37, 72
verifying	37
Controller board LEDs	17, 77
cross-sectional area	19, 38

D	
DAC FS	40
diagnostics	43, 57
diameters,	
downstream	5
straight run	5
upstream	5
DIGSIER	68, 73
duct area	38
E	
electrical codes	11
encasement	3, 25
engineering units	48
explosion-proof enclosure,	
Collector-Box	31
Probe-Box	5
F	
field wiring	7 - 8, 31
filter,	
box car	50
flange sizes	6
flow	71 - 72
flow display	47
flow output signals	61
flow ranges	61
flow rate,	
average	47
flow,	
calculating	23
monitoring	19
function key,	
F1	44
F2	44
F3	45
F4	46
G	
gas density	39
gases	61
H	
heat shrink tubing	26 - 27, 29
hidden configuration parameters	42
high temperature silicon	26 - 27, 29

## O

O-rings	26, 28
operating instructions	17
operation,	
principles of	3
output signals,	
flow	61
temperature	61
outputs,	
relay	51

## P

particulate	17
particulate,	
build-up	5
Pitot tube,	
S-type	21, 44
plane of sensor	6
potentiometers,	
adjustment	54
power supply wiring,	
Probe-Box	11
power,	
input	61
principles of operation	3
probe,	
cleaning	25
duct mounting	5
stack mounting	5
Probe-Box motherboard LEDs	17
protocol,	
RS-485	63
purge air	7, 31

## R

reference method	45
relay outputs	51
repair	59
RJ-25 connector	75 - 76
RMA number	59
RS-232 mode	75 - 76
RS-485 fault	37, 57
RS-485 interface	14, 33, 65
RS-485 interface adapter	66 - 67, 69
RS-485 interface card	65
RS-485 mode	75 - 76
RS-485 protocol	63
RTD	3

**I**

input power,	
115/230 VAC	11 - 12
24 VDC	12 - 13
Collector-Box	61
Probe-Box	11, 61
interface adapter,	
RS-485	15, 66 - 67, 69
interface cables,	
sensor-to-bridge board	57
interface card,	
RS-485	15, 65

**J**

jumper,	
output select	18

**K**

K-factor	38, 44
----------	--------

**L**

LED	43, 50, 61
LED,	
high and low alarm	50
power	49
RS-485 fault	49
sensor fault	49
LEDs,	
Controller board	17
Probe-Box motherboard	17

**M**

maintenance,	
system	25
mass	48 - 49
mass flow	48 - 49
mass flow rate	3
memory,	
non-volatile	37, 42
messages,	
caution	1
warning	1
metal conduit	5, 13, 31
Method 1	21
Method 2	21
microprocessor software	74

## O

O-rings	26, 28
operating instructions	17
operation,	
principles of	3
output signals,	
flow	61
temperature	61
outputs,	
relay	51

## P

particulate	17
particulate,	
build-up	5
Pitot tube,	
S-type	21, 44
plane of sensor	6
potentiometers,	
adjustment	54
power supply wiring,	
Probe-Box	11
power,	
input	61
principles of operation	3
probe,	
cleaning	25
duct mounting	5
stack mounting	5
Probe-Box motherboard LEDs	17
protocol,	
RS-485	63
purge air	7, 31

## R

reference method	45
relay outputs	51
repair	59
RJ-25 connector	75 - 76
RMA number	59
RS-232 mode	75 - 76
RS-485 fault	37, 57
RS-485 interface	14, 33, 65
RS-485 interface adapter	66 - 67, 69
RS-485 interface card	65
RS-485 mode	75 - 76
RS-485 protocol	63
RTD	3

## S

screen drivers	73
sensor fault	57
sensor,	
broken	25
defective	47
FR	3
matching	25
replacing	26
temperature	3
velocity	3
Sierra Instruments Customer Service	26, 28 - 29, 59
signals,	
output	14
software installation	67
software,	
microprocessor	74
standard conditions	3
standard mass velocity	19
standard pressure	19 - 20, 23
standard temperature	19 - 20, 23
standard volumetric flow rate	19
storing setup	42
SW1,	
switch	18, 77
switch SW1	18
system configuration	72

## T

Teflon insulation	27 - 28
temperature	45, 71 - 72
temperature output signals	61
temperature,	
maximum	72
minimum	72
reference	39
standard	39
terminal strip	7, 9 - 10, 27, 29, 31, 57
thermal principle	3
thermophoretic forces	6
thermowell	3, 25
tools	26
totalizer	49, 51, 61
troubleshooting	57

## V

vacuum grease	26, 28
velocity	48 - 49
volumetric flow rate,	
actual	23
standard	23

**W**

wiring,	
input	32
power supply	31
sensor-to-bridge board	13
signal	13 - 14, 32 - 33