

Smart-Trak[®] Model 100

Technical Data Sheet

High Performance Digital Gas Mass Flow Meters and Controllers

Features

- Measure & control gas mass flow rates up to 1000 slpm
- True digital performance provides high accuracy and great flexibility
- Ideal for OEM applications
- Dial-A-Gas[®] Technology lets you select from up to ten pre-programmed gases or substitute your own
- Unique pilot module (local or remote) interface lets you view and change the following control functions:

- Gas
- Setpoint value
- Setpoint source
- Engineering units
- Output signal
- Valve state
- Full scale value
- Password



- All control functions are also available from your PC or workstation via Smart-Trak[®] software
- 316 Stainless steel construction is suitable for any clean gas, even corrosives and toxics
- Small footprint facilitates replacement of any other MFM or MFC
- Single-sided 24 VDC input power reduces installation cost and complexity
- Every Smart-Trak[®] instrument includes the following at no extra charge:
 - Cable or connector
 - Smart-Trak[®] software for Windows OS
 - Digital communication protocol
 - Calibration on NIST traceable Primary Standard with Certificate



Description

Our Smart-Trak[®] Model 100 is our flagship product and is widely recognized as one of the finest MFC's in the world. Smart-Trak has demonstrated that premium flow instrumentation does not have to be hard to use. Ideal for OEM customers and end-users alike, Smart-Trak offers accurate, reliable performance, an easy-to-use interface, rugged 316 stainless-steel construction, and maximum long-term application flexibility.

Smart-Trak is designed so the physics are correct! Excellent performance results from our patented, inherently linear design, advanced platinum sensor technology, and a valve that is strong, flexible, and forgiving.

A key to Smart-Trak's success is its Dial-A-Gas[®] technology. Choose any of ten pre-programmed gases common in industry or pick your own. Each Smart-Trak is available with our innovative and user-friendly Pilot Module, a front-mounted or hand-held control readout device that makes it simple to "Dial-A-Gas", change flow rates, modify engineering units, or even change the full scale value of your instrument. Smart-Trak lets you adjust these operating parameters to accommodate unexpected application or system design changes in the field.

Smart-Trak delivers the performance, flexibility, and value you expect from Sierra Instruments.



Performance Specifications

Accuracy

Standard: +/- 1% of full scale including linearity at operating conditions
(+/- 2% of full scale for 100M from 201 to 300 slpm)

High Accuracy Calibration: +/-0.7% of reading + 0.3% of full scale at calibration conditions

Dial-A-Gas

+/- 1% of full scale in all 10 standard gases (see chart below)

Repeatability

+/- 0.2% of full scale

Temperature Coefficient

+/- 0.025% of full scale per °F (+/- 0.05% of full scale per °C), or better

Pressure Coefficient

+/- 0.01% of full scale per psi (+/- 0.15% of full scale per bar), or better

Response Time

300 millisecond time constant; 2 seconds (typical) to within +/- 2% of final value (includes settling time), Faster or slower available upon request

Operating Specifications

Mass Flow Rates

100L Low Flow: 0 to 10 sccm up to 0 to 50 slpm

100M Medium Flow: 0 to 20 up to 0 to 300 slpm (up to 400 slpm available--Consult Factory)

100H High Flow: 0 to 100 up to 0 to 1000 slpm (higher flows available--Consult Factory)

Flow ranges specified are for an equivalent flow of nitrogen at 760 mm Hg and 21°C (70°F); other ranges in other units are available (e.g., nlpm, scfh, nm³/h, kg/h)

For measuring or controlling flows below 5 sccm, please consider Sierra Model 101 Micro-Trak™

Gases

All clean gases including corrosives & toxics; specify when ordering

The following ten gases make up the Dial-A-Gas® feature of every Smart-Trak instrument; up to nine alternate gases may be substituted.

Dial-A-Gas Flow rates

| Gas | Max Flow Rate (slpm) | Max Flow Rate (slpm) | Max Flow Rate (slpm) |
|-----------------------------------|-------------------------|-------------------------|-------------------------|
| | Low Flow Size | Medium Flow Size | High Flow Size |
| Air | 50 | 300 | 1000 |
| Argon (Ar) | 72.5 | 435 | 1450 |
| Carbon Dioxide (CO ₂) | 37 | 220 | 740 |
| Carbon Monoxide (CO) | 50 | 302 | 1000 |
| Methane (CH ₄) | 36 | 227 | 720 |
| Helium (He) | 72.7 | 420 | 1454 |
| Hydrogen (H ₂) | 50 | 300 | 1000 |
| Oxygen (O ₂) | 50 | 300 | 1000 |
| Nitrogen (N ₂) | 50 | 300 | 1000 |
| Nitrous Oxide (N ₂ O) | 35.5 | 215 | 710 |



Operating Specifications

Gas & Ambient Temperature

32 to 122°F (0 to 50°C)

Gas Pressure

500 psig (34.5 barg) maximum, burst tested to 750 psig (52 barg)

Leak Integrity

5 X 10⁻⁹ atm cc/sec of helium maximum

Power Requirements

(ripple should not exceed 100 mV peak-to-peak)

For Mass Flow Meters:

15 to 24 VDC +/-10%, (130 mA, regulated)

For Mass Flow Controllers:

C100L: 24 VDC +/-10% (400 mA, regulated).

C100M: 24 VDC +/-10%, (700 mA, regulated)

C100H: 24 VDC +/-10%, (1260 mA, regulated)

Control Range For Controllers

2 to 100% of full scale flow; automatic shut-off at 1.9%.

Output Signal

Analog:

- Linear 4 to 20 mA, 500 ohms maximum loop resistance and one of the following (user selectable):
- Linear 0 to 5 VDC, 1000 ohms minimum load resistance
- Linear 0 to 10 VDC, 1000 ohms minimum load resistance
- Linear 1 to 5 VDC, 1000 ohms minimum load resistance

Digital:

- RS-232 standard
- Pilot Module Display optional

Command Signal

Analog (choice of one):

- Linear 4 to 20 mA, 0 to 5 VDC, 0 to 10 VDC, 1 to 5 VDC

Digital:

- RS-232
- Pilot Module Display optional

Wetted Material

316 stainless steel or equivalent; 416 stainless steel; Viton® "O"-rings and valve seat standard; other elastomers are available (consult factory)

Operating Specifications

Pressure Drop Across a Meter

Pressure must be above the values in the table below. Note that pressure increases with flow rate.

| Minimum Pressure Drop for Air, Mass Flow Meters | | | | | |
|---|---|---|-------------------------------------|---|--|
| Flow Rate (slpm) | Pressure Drop in PSI (mbar) | | | | |
| | Low Flow ¼ inch fittings (Standard) | Low Flow ¾ inch fittings (Optional) | Medium Flow ¾ or ½ inch fittings | High Flow Small Bore (100H) (std up to 500 slpm) ½ comp fittings | High Flow Large Bore (H1, H2) (std 501-1000 slpm) ¾ comp fittings |
| 0.1 | 0.36 (24.5) | N/A | N/A | N/A | N/A |
| 0.5 | 0.36 (24.5) | N/A | N/A | N/A | N/A |
| 1 | 0.37 (25.4) | N/A | N/A | N/A | N/A |
| 10 | 0.46 (31.7) | 0.41 (28.6) | N/A | N/A | N/A |
| 20 | 0.66 (45.7) | 0.47 (32.7) | 0.5 (34) | N/A | N/A |
| 30 | N/A | 0.59 (40.9) | 0.5 (34) | N/A | N/A |
| 40 | N/A | 0.77 (53.3) | 0.5 (34) | N/A | N/A |
| 50 | N/A | 1.00 (68) | 0.5 (34) | N/A | N/A |
| 100 | N/A | N/A | 1.0 (68) | 1.0 (68) | 0.5 (34) |
| 150 | N/A | N/A | 2.0 (136) | 1.2 (81.6) | 0.5 (34) |
| 200 | N/A | N/A | 3.0 (204) | 1.5 (102) | 0.5 (34) |
| 250 | N/A | N/A | 4.0 (272) | 1.8 (122.4) | 0.5 (34) |
| 300 | N/A | N/A | 5.5 (374) | 2 (136) | 0.6 (408) |
| 350 | N/A | N/A | N/A | 2.5 (170) | 0.7 (476) |
| 400 | N/A | N/A | N/A | 3 (204) | 0.9 (612) |
| 450 | N/A | N/A | N/A | 3.5 (238) | 1.1 (748) |
| 500 | N/A | N/A | N/A | 4 (272) | 1.3 (884) |
| 750 | N/A | N/A | N/A | 6 (408)* | 3.0 (204) |
| 1000 | N/A | N/A | N/A | 10 (680)* | 5.0 (340) |

Note: Tested at 21°C, outlet at ambient pressure

*Larger fittings recommended for these flow rates, as small fittings reduce overall performance

Differential Pressure Requirement for Controllers (lower or higher available upon request)

Optimum: 30 to 60 psi (2 to 4 bar)

Minimum: See chart below. Note that required pressure increases with flow rate.

| Minimum Differential Pressure Requirement for Air, Mass Flow Controllers | | | | | |
|--|---|---|-------------------------------------|---|--|
| Flow Rate (slpm) | Pressure Drop in PSI (mbar) | | | | |
| | Low Flow ¼ inch fittings (Standard) | Low Flow ¾ inch fittings (Optional) | Medium Flow ¾ or ½ inch fittings | High Flow Small Bore (100H) (std up to 500 slpm) ½ comp fittings | High Flow Large Bore (H1, H2) (std 501-1000 slpm) ¾ comp fittings |
| 0.1 | 1 (68) | 1 (68) | N/A | N/A | N/A |
| 1 | 1.5 (102) | 1.28 (87) | N/A | N/A | N/A |
| 10 | 6 (408) | 3.8 (258) | N/A | N/A | N/A |
| 20 | 12 (816) | 6.6 (449) | 1 (68) | N/A | N/A |
| 30 | 15 (1020) * | 9.4 (639) | 1.2 (82) | N/A | N/A |
| 40 | 30 (2040) * | 12.2 (830) | 1.6 (110) | N/A | N/A |
| 50 | 40 (2720) * | 15 (1020) | 2 (136) | N/A | N/A |
| 100 | N/A | N/A | 5 (340) | 1.5 (102) | 1.0 (68) |
| 150 | N/A | N/A | 10 (680) | 2 (136) | 1.0 (68) |
| 200 | N/A | N/A | 15 (1020) | 4.5 (306) | 1.0 (68) |
| 250 | N/A | N/A | 20 (1360) | 5.5 (374) | 1.5 (102) |
| 300 | N/A | N/A | 25 (1700) | 6.5 (442) | 2.0 (136) |
| 350 | N/A | N/A | N/A | 8.5 (578) | 3.0 (204) |
| 400 | N/A | N/A | N/A | 10.5 (714) | 4.0 (272) |
| 450 | N/A | N/A | N/A | 13 (884) | 5.0 (340) |
| 500 | N/A | N/A | N/A | 15 (1020) | 6.0 (408) |
| 750 | N/A | N/A | N/A | N/A | 15 (1020) |
| 1000 | N/A | N/A | N/A | N/A | 20 (1360) |

Note: Tested at 21°C, outlet at ambient pressure

*Larger fittings recommended for these flow rates as ¼ inch fittings reduce overall performance

Physical Dimensions

Note: All dimensions are in inches with mm in brackets. Certified drawings are available on request.

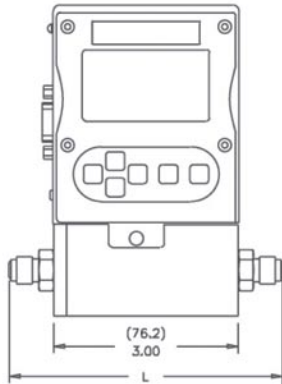
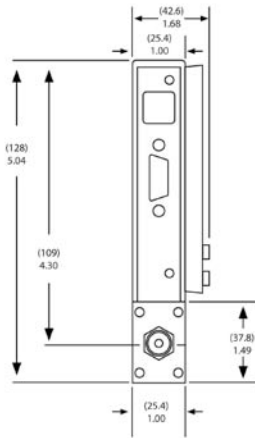
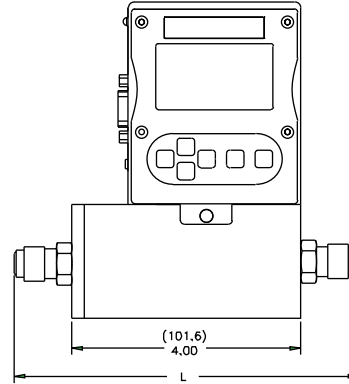
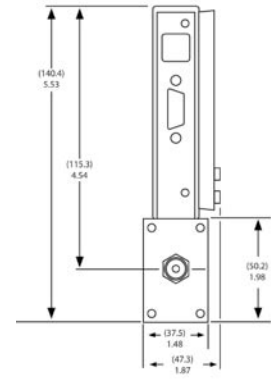
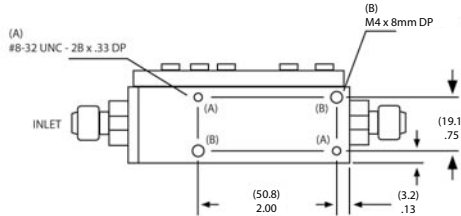
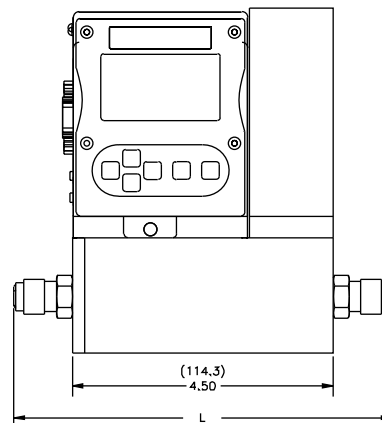
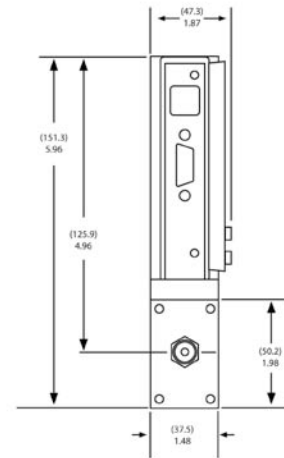
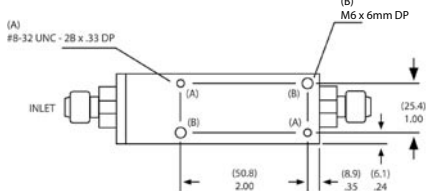
M100L & C100L Front View

M100L & C100L Inlet View

M100M Front View

M100M Inlet View

M100L & C100L Bottom View

C100M Front View

C100M Inlet View

M100M & C100M Bottom View

Notice that 2 of the mounting holes on the bottom are SAE and 2 of the holes are metric.

Dimension L

| Fittings | Length with fittings in inches (mm) | | | | | | |
|--------------------|-------------------------------------|------------|------------|------------|------------|-------------|-------------|
| | C100L/M100L | C100M | M100M | M100H | M100H1, H2 | C100H | C100H1, H2 |
| 1/8 compression | 4.84 (124) | NA | NA | NA | NA | NA | NA |
| 1/4 compression | 5.02 (129) | 6.52 (167) | 6.02 (154) | NA | NA | NA | NA |
| 3/8 compression | 5.14 (132) | 6.64 (170) | 6.14 (157) | NA | NA | NA | NA |
| 1/2 compression | 5.3 (136) | 6.80 (174) | 6.30 (162) | 8.92 (229) | NA | 10.37 (266) | NA |
| 1/4 VCO | 4.56 (117) | 6.06 (155) | 5.56 (143) | NA | NA | NA | NA |
| 1/2 VCO | 5.00 (128) | 6.50 (167) | 6.00 (154) | 8.56 (220) | NA | 10.01 (257) | NA |
| 3/4 VCO | NA | NA | NA | NA | 8.78 (225) | NA | 11.28 (289) |
| 1/4 VCR | 4.88 (125) | 6.38 (164) | 5.88 (151) | NA | NA | NA | NA |
| 1/2 VCR | 5.18 (133) | 6.68 (171) | 6.18 (158) | 8.98 (230) | NA | 10.43 (267) | NA |
| 6 mm compression | 5.04 (129) | 6.54 (168) | 6.04 (155) | NA | NA | NA | NA |
| 10 mm compression | 5.20 (133) | 6.70 (172) | 6.20 (159) | NA | NA | NA | NA |
| 12 mm compression | 5.38 (138) | 6.88 (176) | 6.38 (164) | 8.90 (228) | NA | 10.35 (265) | NA |
| 1/4 FNPT | 4.85 (124) | 6.35 (163) | 5.85 (150) | NA | NA | NA | NA |
| 3/8 FNPT | NA | 6.50 (167) | 6.00 (154) | NA | NA | NA | NA |
| 1/2 FNPT | NA | NA | NA | 9.14 (234) | NA | 10.59 (272) | NA |
| 3/4 FNPT | NA | NA | NA | NA | 9.30 (238) | NA | 11.80 (303) |
| 3/4 compression | NA | NA | NA | 9.24 (237) | 9.18 (235) | 10.69 (274) | 11.68 (300) |
| 1 inch compression | NA | NA | NA | NA | 9.52 (244) | NA | 12.02 (308) |

Physical Dimensions

Note: All dimensions are in inches with mm in brackets. Certified drawings are available on request.

M100H,H1,H2 Front View

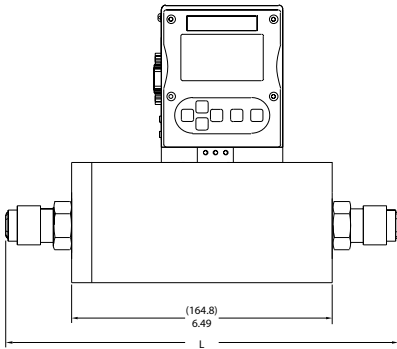

M100H,H1,H2 Side View

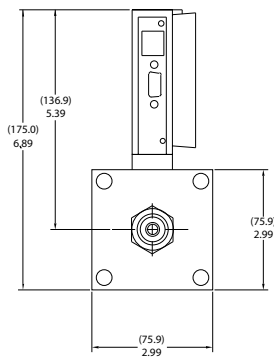

M100H,H1,H2 Bottom View

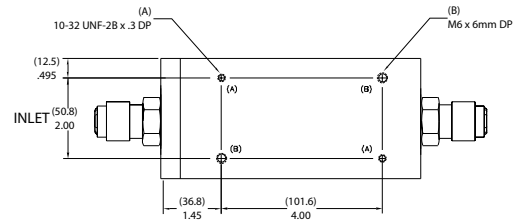

C100H Front View

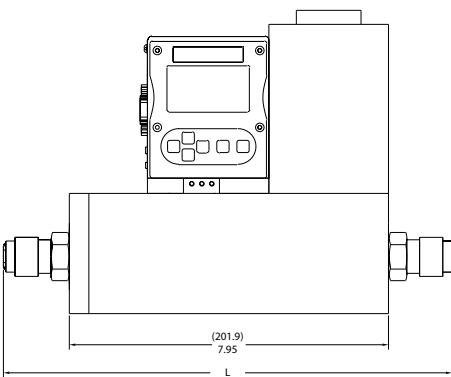

C100H Side View

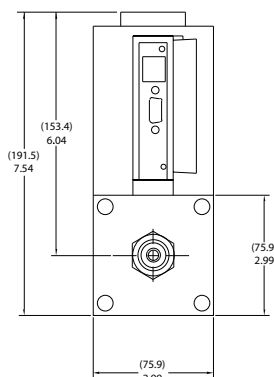

C100H Bottom View

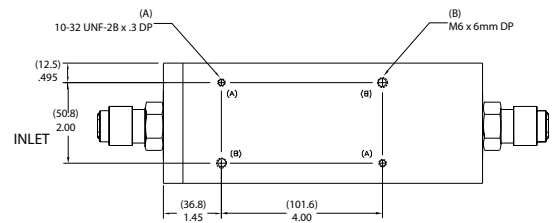

C100H1,H2 Front View

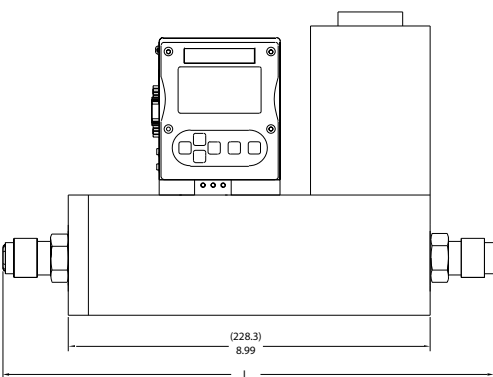

C100H1,H2 Side View

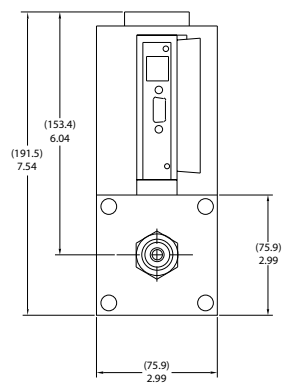

C100H1,H2 Bottom View

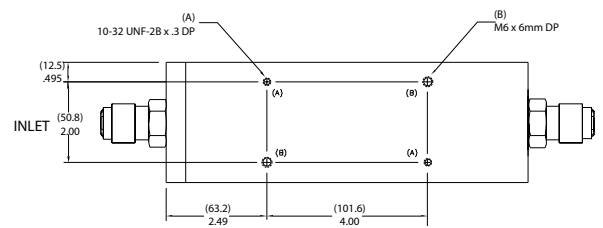

Ordering the Smart-Trak®

| | |
|--|--|
| PARENT NUMBER | |
| M 100 Smart-Trak Mass Flow Meter | |
| C 100 Smart-Trak Mass Flow Controller | |
| FLOW RANGE | |
| L Flows from 0-10 sccm to 0-50 slpm | |
| M Flows from 0-20 slpm to 0-200 slpm | |
| M1 Flows from 0-201 slpm to 0-300 slpm | |
| H Flows from 0-100 slpm to 0-500 slpm | |
| H1 Flows from 0-501 slpm to 0-800 slpm | |
| H2 Flows from 0-801 slpm to 0-1000 slpm | |
| PILOT MODULE DISPLAY/INTERFACE | |
| NR No Display/Interface | |
| DD Pilot Module Display/Interface | |
| RD Remote Pilot Module Display/Interface | |
| INLET/OUTLET FITTINGS | |
| 1 1/8 compression (max 5 slpm) | 10 6mm compression (max 30 slpm) |
| 2 1/4 compression (Std to 30 slpm) | 11 10mm compression (max 300 slpm) |
| 3 3/8 compression (Std 30 to 300 slpm) | 12 12 mm compression (max 500 slpm) |
| 4 1/2 compression (max 500 slpm) | 13 1/4 FNPT (max 300 slpm) |
| 5 1/4 VCO (max 50 slpm) | 14 3/8 FNPT (max 300 slpm) |
| 6 1/2 VCO (max 500 slpm) | 15 1/2 FNPT (max 500 slpm) |
| 7 3/4 VCO (max 1000 slpm) | 16 3/4 FNPT (max 1000 slpm) |
| 8 1/4 VCR (max 50 slpm) | 17 3/4 compression (max 1000 slpm) |
| 9 1/2 VCR (max 500 slpm) | 18 1 inch compression |
| FLOW BODY ELASTOMERS | |
| OV1 Viton® or equivalent (Standard) | |
| ON1 Neoprene or equivalent | |
| VALVE SEAT (C100 Flow Controllers Only) | |
| SV1 Viton® or equivalent | |
| SN1 Neoprene or equivalent | |
| SK1 Kalrez® or equivalent (100L) | |
| SK2 Kalrez® or equivalent (100M) | |
| SK3 Kalrez® or equivalent (100H) | |
| INPUT POWER | |
| PV1M 15 to 22 VDC, linear (Flow Meters Only) | |
| PV2 24 VDC, linear (Standard) | |
| OUTPUT SIGNAL | |
| V1 4 to 20 mA and 0 to 5 VDC, Linear | |
| V2 4 to 20 mA and 1 to 5 VDC, Linear | |
| V3 4 to 20 mA and 0 to 10 VDC, Linear | |
| EXTERNAL SETPOINT SIGNAL (Flow Controllers Only) | |
| S0 Pilot Module/RS-232 (Standard for DD, RD) | |
| S1 0 to 5 VDC (Standard for NR) | |
| S2 1 to 5 VDC | |
| S3 0 to 10 VDC | |
| S4 4 to 20 mA | |
| ELECTRICAL CONNECTION | |
| C0 15 PIN mating connector with no cable | |
| C1 6 inch (150 mm) cable | |
| C3 3 foot (1m) cable | |
| C10 10 foot (3m) cable | |
| C () Custom length cable | |
| OPTIONS | |
| A1 High Accuracy Calibration | |
| GS Gas Substitution (Replace up to 9 Dial-A-Gas® Gases) | |
| LF Low Flow Calibration (required for 0 to 20 sccm and below) | |
| GAS FLOW RATE | |

FOR ACCESSORIES AND ADDITIONAL CABLES PLEASE CONTACT YOUR LOCAL SIERRA DISTRIBUTOR

SIERRA INSTRUMENTS, NORTH AMERICA • 5 Harris Court, Building L • Monterey, California • (800) 866-0200 • (831) 373-0200 • Fax (831) 373-4402 • www.sierrainstruments.com

SIERRA INSTRUMENTS, EUROPE • Bijlmansweid 2 • 1934RE Egmond aan den Hoef • The Netherlands • +31 72 5071400 • Fax: +31 72 5071401

SIERRA INSTRUMENTS, ASIA • Rm.618, Tomson Centre, Bldg. A • 188 Zhang Yang Road • Pu Dong New District • Shanghai, P.R. China 200122 • +8621 5879 8522 • Fax: +8621 5879 8586