

**Sierra 780S Series Flat-Trak™
Mass Flow Meter**

Instruction Manual

Part Number IM-78S
07/99 Revision B



5 Harris Court, Building L Monterey, CA 93940
(831) 373-0200 (800) 866-0200 Fax (831) 373-4402
<http://www.sierrainstruments.com>

Sierra Instruments b.v. Bolstoen 30A 1046 AV Amsterdam The Netherlands
+31(0)20-6145810 Fax +31(0)20-6145815

Customer Notice

Sierra Instruments, Inc. is not liable for any damage or personal injury, whatsoever, resulting from the use of Sierra Instruments standard mass flow meters for oxygen gas. You are responsible for determining if this mass flow meter is appropriate for your oxygen application. You are responsible for cleaning the mass flow meter to the degree required for your oxygen flow application.

© COPYRIGHT SIERRA INSTRUMENTS 1998

No part of this publication may be copied or distributed, transmitted, transcribed, stored in a retrieval system, or translated into any human or computer language, in any form or by any means, electronic, mechanical, manual, or otherwise, or disclosed to third parties without the express written permission of Sierra Instruments. The information contained in this manual is subject to change without notice.

TRADEMARKS

Flat-Trak™, Steel-Trak™ and Smart Interface™ software are trademarks of Sierra Instruments, Inc. Other product and company names listed in this manual are trademarks or trade names of their respective manufacturers.

All Sierra products are Year 2000 compliant.

Table of Contents

Chapter 1 Introduction

Series 780S Flat-Trak Mass Flow Meters	1-1
Using this Manual.....	1-1
Note and Safety Information.....	1-2
Receipt of System Components	1-2
Technical Assistance.....	1-2
The Series 780S Flow Sensing Principle.....	1-3
Smart Electronics Features.....	1-4
Enclosure Options	1-5
Smart Interface™ Software.....	1-5

Chapter 2 Installation and Wiring

Installation Overview.....	2-1
Unobstructed Flow Requirements.....	2-2
Installing the Flow Meter	2-2
Changing Display Orientation.....	2-3
Wiring Connections	2-4
Input Power Wiring.....	2-5
Output Signal Wiring	2-7
Alarm Output Wiring.....	2-10
Remote Sensor Probe Wiring.....	2-11
Range Selection Wiring.....	2-13

Chapter 3 Operating Instructions

Flow Meter Start Up.....	3-1
Using the Smart Electronics Basic Features.....	3-2
Hazardous-Area Enclosure Optional LCD Display.....	3-2
LCD Display Programming Menu.....	3-3
Single-Digit LED Programming Menu.....	3-4
Entering Alarm Parameters.....	3-5
K-Factor Adjustment.....	3-6
User Full Scale Adjustment.....	3-7
Time Response Delay Adjustment.....	3-8
Totalizer Reset.....	3-9
Using the Smart Electronics Advanced Features.....	3-11
Voltage Zero Adjustment.....	3-11
Voltage Span Adjustment.....	3-11
Current Zero Adjustment.....	3-12
Current Span Adjustment.....	3-12
Instrument Validation.....	3-13
Electronics Validation Procedure.....	3-14
Sensor Validation Procedure.....	3-15

Chapter 4 Troubleshooting and Repair

Troubleshooting the Flow Meter.....	4-1
Returning Equipment to the Factory.....	4-3

Appendix A Product Specifications

List of Figures

1-1. Series 780S Flow Sensing Principle	1-3
2-1. Flow Meter Orientation.....	2-2
2-2. Wiring Access NEMA 4X Enclosures	2-4
2-3. Wiring Access Hazardous-Area Enclosures.....	2-4
2-4. AC Input Power Connections.....	2-5
2-5. Ferrite Clamp Installation.....	2-5
2-6. DC Input Power Connections (NEMA 4X)	2-6
2-7. DC Input Power Connections (Hazardous-Area).....	2-6
2-8. DC Output Signal Connections (NEMA 4X).....	2-7
2-9. DC Output Signal Connections (Hazardous-Area).....	2-7
2-10. Load Resistance Versus Input Voltage.....	2-8
2-11. Isolated 4-20 mA Loop (NEMA 4X).....	2-9
2-12. Non-isolated 4-20 mA Loop (NEMA 4X).....	2-9
2-13. Isolated 4-20 mA Loop (Hazardous-Area).....	2-9
2-14. Non-isolated 4-20 mA Loop (Hazardous-Area).....	2-9
2-15. Isolated Alarm Connections (NEMA 4X).....	2-10
2-16. Non-Isolated Alarm Connections (NEMA 4X)	2-10
2-17. Isolated Alarm Connections (Hazardous-Area)	2-11
2-18. Non-isolated Alarm Connections (Hazardous-Area)	2-11
2-19. Remote Electronics to Sensor (NEMA 4X).....	2-12
2-20. J Box to Remote Enclosure (NEMA 4X).....	2-12
2-21. Remote Electronics to Sensor (Hazardous-Area)	2-12
2-22. J Box to Remote Enclosure (Hazardous-Area).....	2-13
2-23. Range Selection Wiring (NEMA 4X)	2-13
2-24. Range Selection Wiring (Hazardous-Area).....	2-13
3-1. Smart Electronics Device Locations	3-1
3-2. Magnetic Switch Operation.....	3-2
3-3. Electronics Validation Component Locations.....	3-13
3-4. Sensor Validation Component Locations	3-15

List of Tables

2-1. Pipe Length Requirements for Installation.....	2-2
3-1. Electronics Validation Results.....	3-15
3-2. Sensor Validation Results.....	3-16

Warnings and Cautions



Warning! Agency approval for hazardous location installations varies between flow meter models. Consult the flow meter nameplate for specific flow meter approvals before any hazardous location installation.

Warning! All wiring procedures must be performed with the power off.

Warning! To avoid potential electric shock, follow National Electric Code safety practices or your local code when wiring this unit to a power source and to peripheral devices. Failure to do so could result in injury or death. All AC power connections must be in accordance with published CE directives.

Warning! Do not power the flow meter with the sensor jumper wires disconnected. This could cause over-heating of the sensors and/or damage to the electronics.

Warning! Before attempting any flow meter repair, verify that the line is de-pressurized.

Warning! Always remove main power before disassembling any part of the mass flow meter.



Caution! Changing the length of cables or interchanging sensors or sensor wiring will affect the accuracy of the flow meter. You cannot add or subtract wire length without returning the meter to the factory for re-calibration.

Caution! When using toxic or corrosive gases, purge the line with inert gas for a minimum of four hours at full gas flow before installing the meter.

Caution! The AC wire insulation temperature rating must meet or exceed 71°C (158°F).

Caution! Before making adjustments to the Smart Electronics device, verify the flow meter is not actively monitoring or reporting to any master control system. Adjustments to the electronics will cause direct changes to flow control settings.

Caution! Printed circuit boards are sensitive to electrostatic discharge. To avoid damaging the board, follow these precautions to minimize the risk of damage:

- before handling the assembly, discharge your body by touching a grounded, metal object
- handle all cards by their edges unless otherwise required
- when possible, use grounded electrostatic discharge wrist straps when handling sensitive components

Chapter 1 Introduction

Series 780S Flat-Trak™ Mass Flow Meters

Sierra's Series 780S Flat-Trak Mass Flow Meter provides a reliable solution for monitoring gas mass flow rate. Low-flow sensitivity, fast response and outstanding rangeability have made this model the instrument of choice for many critical gas flow applications. The Series 780S meter solves the problems associated with monitoring flow in installations where long runs of straight pipe are not available. The instrument's built-in flow conditioner creates a uniform velocity profile by means of two stainless-steel perforated plates welded into the body between the sensor and the inlet connection. With flow conditioning, upstream piping requirements are reduced to less than three diameters after most common flow disturbances.

The flow meter's versatile microprocessor-based transmitter integrates the functions of flow-range adjustment, meter validation and diagnostics in a probe-mounted or remotely mounted housing. Mass flow rate and totalized flow, as well as other configuration variables are displayed on the meter's optional LCD display. The meter provides an optical/galvanic isolated flow output, two alarm outputs and one contact input for range or gas selection. The programmable transmitter is easily configured via RS-232 and Sierra's Smart Interface™ software or through three push buttons built into the device.

The Series 780S Mass Flow Meter's simple installation combines with an easy-to-use interface that provides quick set up, long term reliability and accurate mass flow measurement over a wide range of flows and conditions.

Using This Manual

This manual provides the information you need to install and operate the Series 780S Mass Flow Meter. The four chapters of this manual cover the following areas:

- Chapter 1 includes the introduction and product description
- Chapter 2 provides installation and wiring instructions
- Chapter 3 describes system operation and programming
- Chapter 4 covers troubleshooting and repair

The product specifications are found in Appendix A.

Note and Safety Information

We use note, caution and warning statements throughout this book to draw your attention to important information.



Warning!

This statement appears with information that is important to protect people and equipment from damage. Pay very close attention to all warnings that apply to your application.



Caution!

This statement appears with information that is important for protecting your equipment and performance. Read and follow all cautions that apply to your application.



Note

This statement appears with a short message to alert you to an important detail.

Receipt of System Components

When receiving a Sierra mass flow meter, carefully check the outside packing carton for damage incurred in shipment. If the carton is damaged, notify the local carrier and submit a report to the factory. Remove the packing slip and check that all ordered components are present. Make sure any spare parts or accessories are not discarded with the packing material. Do not return any equipment to the factory without first contacting Sierra Customer Service.

Technical Assistance

If you encounter a problem with your flow meter, review the configuration information for each step of the installation, operation and setup procedures. Verify that your settings and adjustments are consistent with factory recommendations. Refer to Chapter 4, Troubleshooting, for specific information and recommendations.

If the problem persists after following the troubleshooting procedures outlined in Chapter 4, contact Sierra Instruments by fax or by E-mail (see inside front cover). For urgent phone support you may call (800) 866-0200 or (831) 373-0200 between 8:00 a.m. and 5:00 p.m. PST. In Europe contact Sierra Instruments bv at +31 20 6145810. When contacting Technical Support, make sure to include this information:

- the flow range, serial number and Sierra order number (all marked on the meter nameplate)
- the software version (visible at start up)
- the problem you are encountering and any corrective action taken
- application information (gas, pressure, temperature and piping configuration)

The Series 780S Flow Sensing Principle

Sierra's unique Steel-Trak™ sensor probe is responsible for the unsurpassed accuracy, ruggedness and reliability of Sierra industrial flow meters. The immersible Steel-Trak sensor consists of two sensing elements—a velocity sensor and a temperature sensor that automatically corrects for changes in gas temperature.

When power is applied to the flow meter, the transducer electronics heats the velocity sensor to a constant temperature differential above the gas temperature and measures the cooling effect of the gas flow. The electrical power required to maintain a constant temperature differential is directly proportional to the gas mass flow rate.

Both sensors are reference-grade platinum resistance temperature detectors (RTDs). The platinum RTD wire is wound on a rugged ceramic mandrel for strength and stability. Steel-Trak sensors are clad in a rugged, sealed 316 stainless steel encasement.

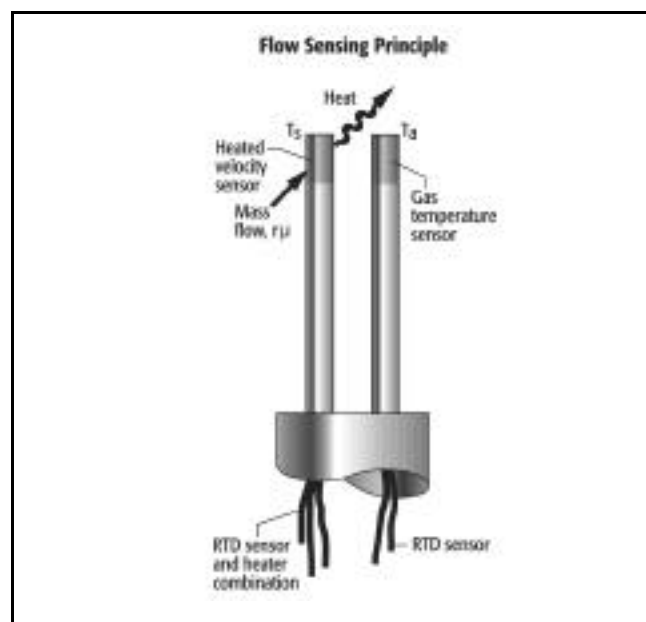

Figure 1-1. Series 780S Flow Sensing Principle

Smart Electronics Features

Instrument Validation

Two simple tests offer full “field-validation” of your Smart mass flow meter. The first test checks the system electronics, linearization and microprocessor functionality and is performed by injecting a known input value and confirming that the flow meter outputs the expected value. The second test verifies that the instrument’s primary sensing elements have not drifted or shifted from their original calibration and is accomplished by measuring the resistance of the velocity and temperature sensors and comparing the results to the NIST-traceable calibration data provided with the flow meter. Together, these tests confirm that your meter is working correctly and the calibration variables did not drift, shift or change values.

Dual Range or Dual Gas Calibration (Optional)

Select one of two factory calibrated flow ranges using a simple external customer-supplied single contact closure.

User Full Scale Flow Rate

Field-configure from 50% to 100% of the factory full scale setting (factory full scale is normally set to 125% of the user-specified maximum flow rate). This adjustment can be made for each flow range.

Alarms

Program high and low or window alarm limits independently for each flow range. The solid state contacts are optically isolated.

K-Factor Correction

Change the calibration correction factor to compensate for flow profile disturbances or specific application conditions. The K-factor is a multiplication factor applied to the linearized flow signal. You may set the K-factor individually for each flow range.

Dual Output Signals

The flow meter offers two separate linear output signals proportional to flow, 0-5 VDC (0-10 VDC optional) and 4-20 mA. The 4-20 mA output can be field-configured as an active loop powered by the flow meter or an optically isolated passive loop requiring an external power supply.

Totalizer

With the optional LCD display, actual mass flow appears on line 1 and the totalized flow on line 2 both in the user-specified engineering units. The totalizer counts only the selected range and when ranges are switched, the value of the non-selected range is stored in memory. You may reset the totalizer using the membrane buttons or by using a hand-held magnet.

Zero and Span Outputs

Validate and adjust the settings to ensure output circuits are correct.

Time Response Delay

Select from a low response for faster tracking to a high response for a smoother output.

Enclosure Options

Flow meter electronics are available mounted directly to the flow body, or remotely mounted up to 200 feet away. The electronics housing may be used indoors or out, including wet environments.

Display options include a 2 x 12 character LCD display of mass flow rate including totalized mass, or a single-digit LED located on the device printed circuit board. Local operation and reconfiguration is accomplished using the three push buttons operated via finger touch. Smart electronics include nonvolatile memory that stores all configuration information. The memory allows the flow meter to function immediately upon power up, or after an interruption in power.

Smart Interface™ Software

Sierra's Smart Interface Windows™-based software is available for connecting your PC directly to the mass flow meter. An RS-232 serial cable along with floppy disks containing the program and system files are available from the factory. See the Smart Interface User Guide included with the software package for operating instructions. (Order code for this package is 780-SIP.)

Chapter 2 Installation

Installation Overview

**Warning!**

Agency approval for hazardous location installations varies between flow meter models. Consult the flow meter nameplate for specific flow meter approvals before any hazardous location installation.

The Series 780S Flat-Trak™ is available with ANSI or DIN flanges, NPT or butt-weld connections. For ease of installation, the meter is pre-assembled with the sensor probe installed in the flow body.

When selecting an installation site, make sure that:

1. Line pressure and temperature will not exceed the flow meter rating. Temperature should not vary more than 200°F (100°C) around the calibration temperature. Line pressure should not vary more than 50 psi (3.4 bar) around the calibrated pressure.
2. The location meets the required minimum number of pipe diameters upstream and downstream of the sensor head (see Table 2-1).
3. Safe and convenient access with adequate clearance. Also, verify the meter is located where the gas is clean and dry and the meter is calibrated for the gas to be measured.
4. When using a CSA, FM or EEx approved flow meter, verify that the cable entry into the instrument meets the specific standard required for that approval.
5. For remote installations, verify the supplied cable length is sufficient to connect the flow meter sensor to the remote electronics. (Do not extend or shorten the supplied cable between the probe and the electronics.)

Also, before installation check your flow system for anomalies such as:

- leaks
- valves or restrictions in the flow path that could create disturbances in the flow profile that might cause unexpected flow rate indications
- heaters that might cause rapid excursions in the measured temperature

Unobstructed Flow Requirements

Select an installation site that will minimize possible distortion in the flow profile. Valves, elbows, control valves and other piping components may cause flow disturbances. Check your specific piping condition against the examples shown below. To achieve accurate and repeatable performance, install the flow meter using the recommended number of straight run pipe diameters upstream of the sensor.

Piping Condition	Upstream ⁽¹⁾ Requirements
Single 90° elbow or T-piece	1 D
Reduction (4:1)	3 D
Expansion	3 D
After a control valve	3 D
Two 90° elbows (in same plane)	3 D
Two 90° elbows (different planes)	5 D

(1) Number of diameters (D) of straight pipe required between upstream disturbance and the flow meter sensor.

Table 2-1. Pipe Length Requirements for Installation

Installing the Flow Meter

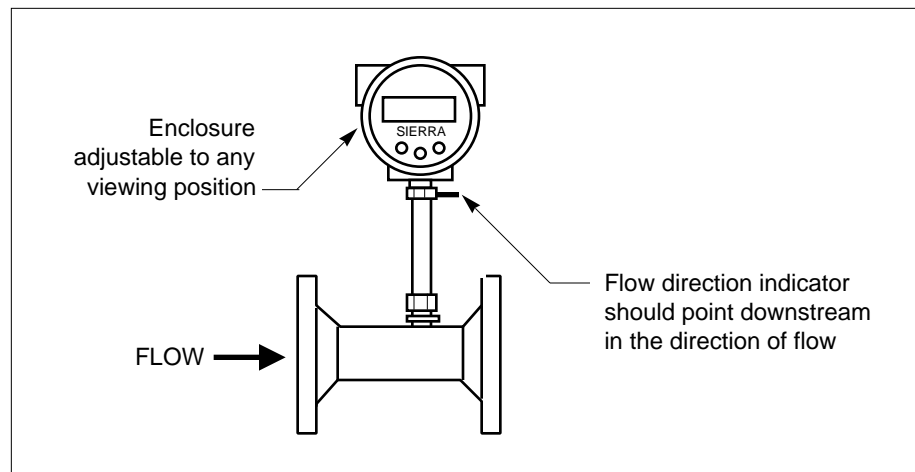

Figure 2-1. Flow Meter Orientation (Flange Connection Shown)

When positioning the flow meter, refer to the flow direction indicator attached to the probe. For proper operation, install the meter with the flow direction indicator pointing downstream in the direction of flow. Installing the meter opposite this direction may result in inaccurate flow measurement.

**Caution!**

When using toxic or corrosive gases, purge the line with inert gas for a minimum of four hours at full gas flow before installing the flow meter.

To install the flow meter:

1. Turn off the flow of process gas. Verify that the line is not pressurized. Confirm that the installation site meets the minimum upstream pipe diameter requirements shown in Table 2-1.
2. Prepare the fluid connection fittings or flanges in the pipeline. (Fitting components should be blown clean with filtered gas before use.) Mount in a vertical position. For horizontal pipelines having a process gas temperature above 300° F (130°C), mount the flow meter at a 90-degree angle to avoid overheating the electronics enclosure.
3. Seat the flow meter level and square on the mating fluid connections with a gasket in place for each side for flange types. (Make sure both gaskets are smooth and even with no gasket material protruding into the flow profile; obstructions in the pipeline could cause inaccurate flow measurement.) Make sure that the flow direction indicator is pointing downstream in the direction of flow.
4. Secure the fluid connections as specified in the technical guidelines furnished by the fitting or flange manufacturer.
5. If needed, adjust the optional display to the desired orientation, as follows.

Changing Display Orientation (Hazardous-Area Enclosures Only)

Depending on installation requirements, you may need to change the position of the optional display. To rotate the display board:

1. Use a 1/16-inch hex key to loosen the set screw securing the larger end of the enclosure. Turn cover counterclockwise and remove.
2. Remove 4 screws and standoffs from the display. Release the latch securing the display ribbon cable connector from the display board.
3. Rotate the display board to the desired position. Re-connect the ribbon cable to the display board.
4. Replace the 4 screws and standoffs. Replace the enclosure cover. Tighten set screw.

Wiring Connections



Warning!

To avoid potential electric shock, follow National Electric Code safety practices or your local code when wiring this unit to a power source and to peripheral devices. Failure to do so could result in injury or death. All AC power connections must be in accordance with published CE directives.

For NEMA 4X enclosures, use TB2 for power and signal connections, TB1 is for sensor connections. (The terminal designations are labeled inside the enclosure cover.)

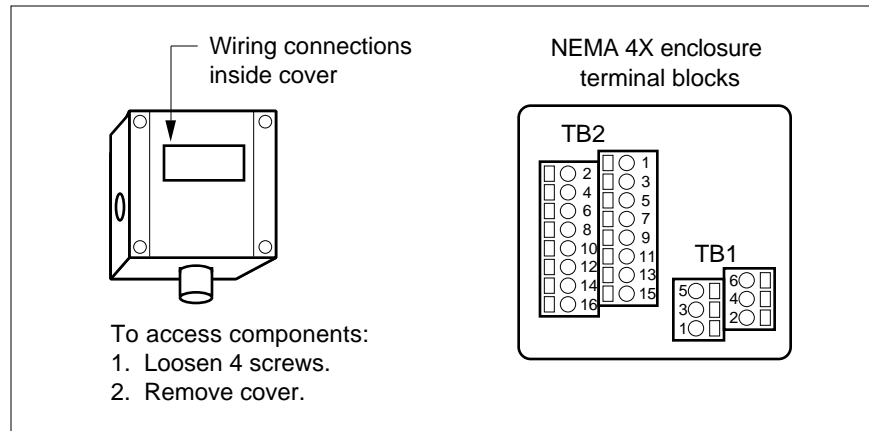

Figure 2-2. Wiring Access NEMA 4X Enclosures

For Hazardous-Area enclosures, use the terminal blocks located inside the smaller end of the flow meter enclosure for all wiring connections. (The terminal designations are labeled inside the enclosure cover.) Make sure to observe all CE compliance requirements for AC wiring connections given on the next page.

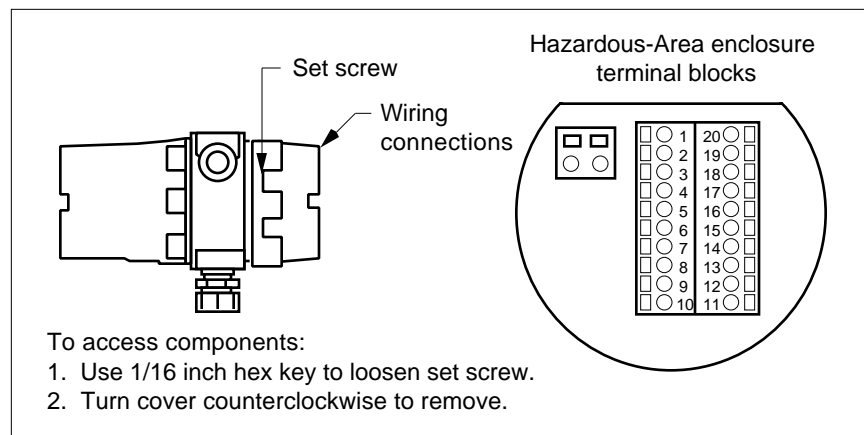

Figure 2-3. Wiring Access Hazardous-Area Enclosures

Input Power Wiring



Warning!

All wiring procedures must be performed with the power Off.



Caution!

The AC wire insulation temperature rating must meet or exceed 71°C (158°F).

AC Power Wiring

The AC power wire size must be 26 to 16 AWG with the wire stripped 1/4 inch (6 mm). Connect 100 to 240 VAC (300 mA load, maximum) to the Neutral and Line terminals on the small, two-position terminal block. Connect the ground wire to the safety ground lug. Torque all connections to 4.43 to 5.31 in-lbs (0.5 to 0.6 Nm).

For all installations not using solid metal conduit, the ferrite clamp must be installed just above the input power wire entry into the enclosure (Figure 2-5). All EEx installations must use an approved EEx fitting at both cable entries into the enclosure. If conduit seals are used, they must be installed with 18 inches of the enclosure.

The Hazardous-Area enclosure has two separate conduit entries to maintain separation between AC input power and output signal wiring. To eliminate the possibility of noise interference use a separate cable entry for the AC power and signal lines.

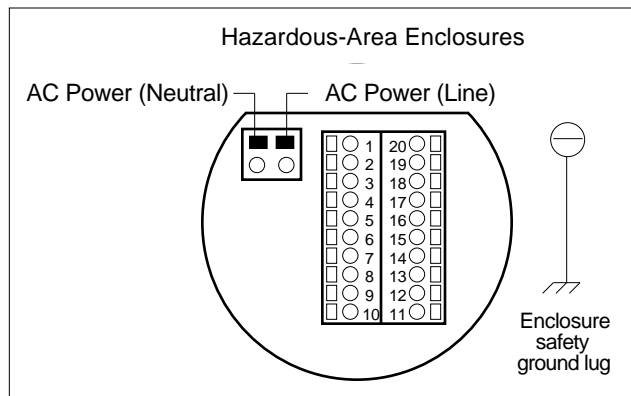

Figure 2-4. AC Input Power Connections

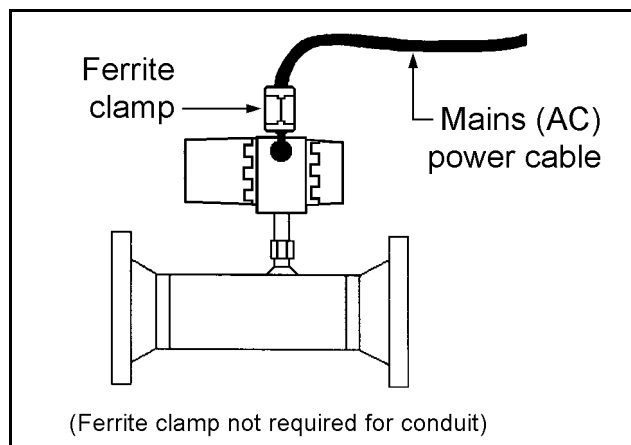

Figure 2-5. Ferrite Clamp Installation

**Warning!**

All wiring procedures must be performed with the power Off.

DC Power Wiring

The DC power wire size must be 26 to 16 AWG with the wire stripped 1/4 inch (6 mm). Connect 18 to 30 VDC (625 mA load, maximum) to the terminals marked PWR+ and PWR- on the terminal block. Torque all connections to 4.43 to 5.31 in-lbs (0.5 to 0.6 Nm).

All EEx installations must use an approved EEx fitting at both cable entries into the enclosure. If conduit seals are used, they must be installed within 18 inches of the enclosure.

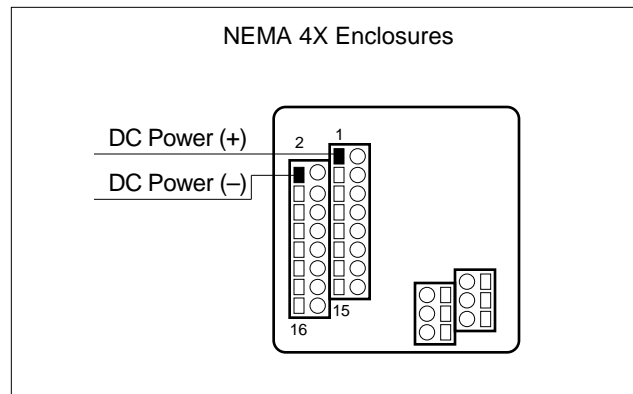

Figure 2-6. DC Input Power Connections

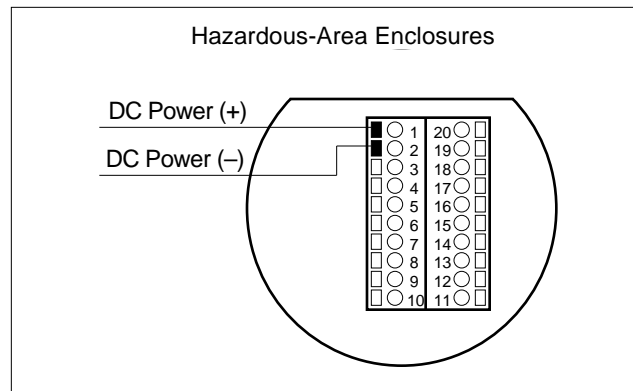

Figure 2-7. DC Input Power Connections

Output Signal Wiring

Output signal cable should be completely screened with a 100% shield. You must use metal cable glands that provide cable screen clamping. The cable screen should be connected to the gland and shielded at both ends over 360 degrees. The shield should be terminated to an earth ground.

Flow meters are equipped with either a calibrated 0-5 VDC (0-10 VDC optional) or a calibrated 4-20 mA output signal. This linear output signal represents 0-100% of the flow meter's user full scale.

DC Output Wiring

The 0-5 VDC (0-10 VDC optional) signal can drive a minimum load of 1000 Ohms. Note: the optional 0-10 VDC output signal is not available for power sources below 15 VDC.

For 0-5 VDC or 0-10 VDC connections, connect to the terminals marked Vout (+) and Vout (-) as shown below.

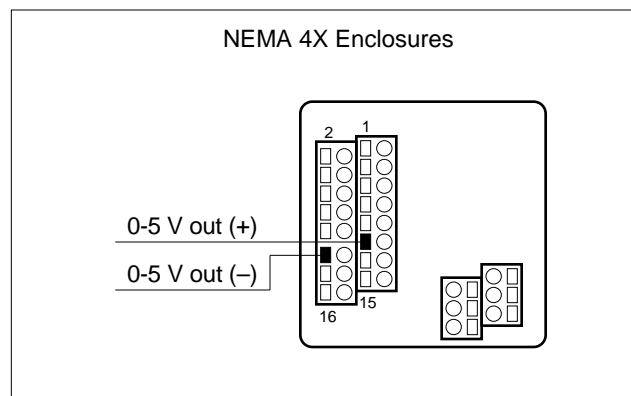

Figure 2-8. DC Output Signal Connections

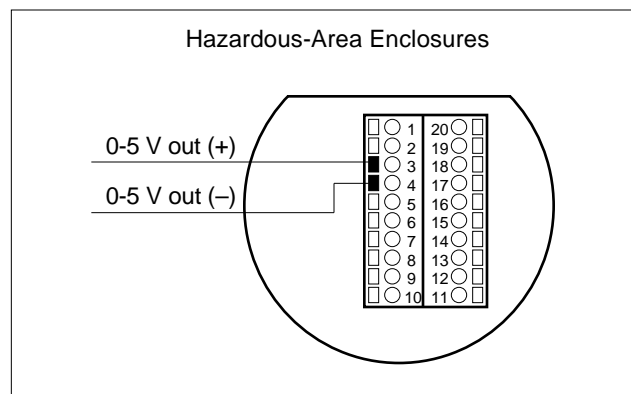

Figure 2-9. DC Output Signal Connections

4-20 mA Output Wiring

The 4-20 mA current loop output can be self-powered (non-isolated) or externally powered (isolated). To use the 4-20 mA isolated output, an external 12 to 36 VDC power supply is required. The maximum loop resistance (load) for both types of current loop outputs are dependent upon the supply voltage and are given in Figure 2-10.

R_{load} is the total resistance in the loop, including the wiring resistance. To calculate R_{max} , the maximum R_{load} for the loop, use the maximum loop current, 20 mA. The voltage drop in the loop due to resistance is 20 mA times R_{load} and this drop is subtracted from the input voltage. Thus:

$$R_{max} \text{ the maximum load resistance} = 50 * (V_{supply} - 7.5V)$$

To use an external power supply for an isolated 4-20 mA output, connect as shown in Figure 2-11 or Figure 2-13. For an internally powered, non-isolated 4-20 mA output, connect as shown in Figure 2-12 or Figure 2-14.

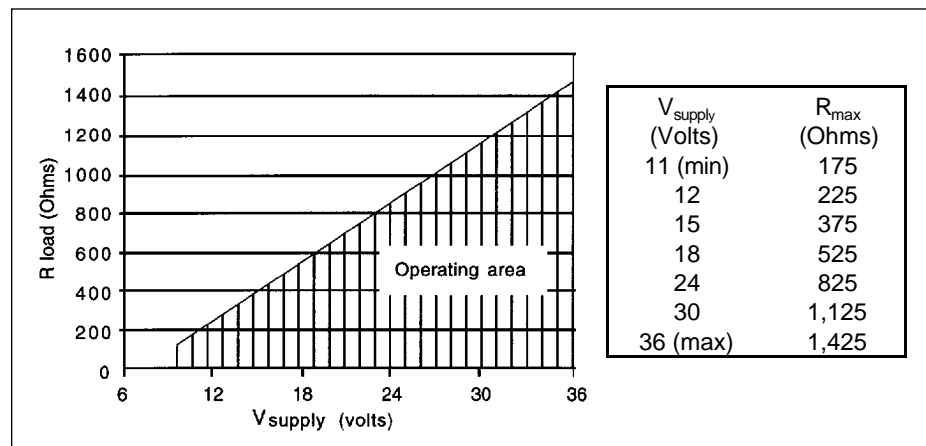

Figure 2-10. Load Resistance Versus Input Voltage

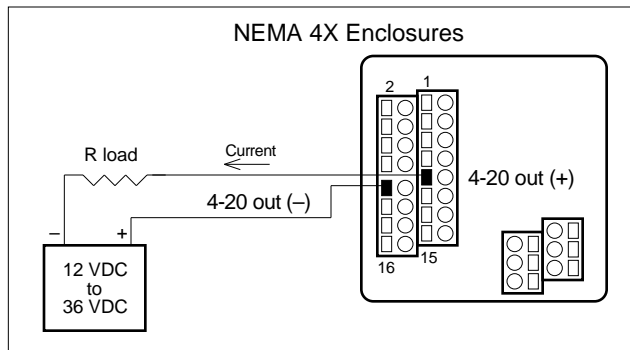

Figure 2-11. Isolated 4-20 mA Current Loop Connections

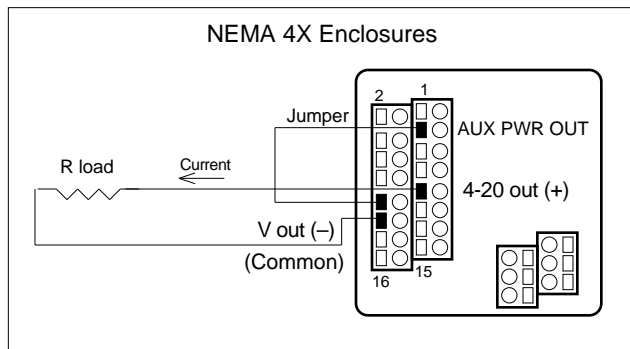

Figure 2-12. Non-Isolated 4-20 mA Current Loop Connections

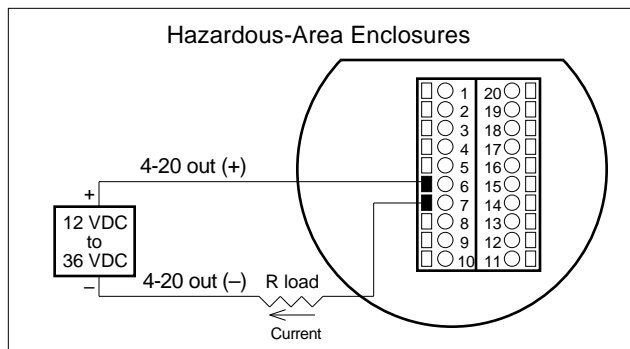

Figure 2-13. Isolated 4-20 mA Current Loop Connections

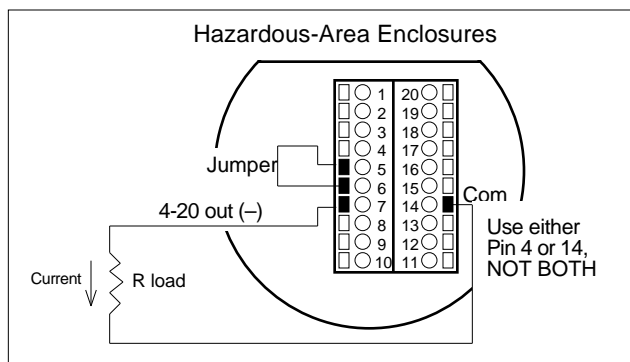

Figure 2-14. Non-Isolated 4-20 mA Current Loop Connections

Alarm Output Wiring

Two alarm outputs (Low Alarm and High Alarm) are included on the flow meter terminal block. The alarm outputs use optical relays that are normally-open single-pole relays with one common connection.

There are two connection options for alarm outputs—the first with a separate power supply (isolated) and the second using the flow meter power supply (non-isolated). Use the first option with a separate power supply if a specific voltage is needed for the alarm output. Use the second (non-isolated) configuration if the voltage at the flow meter's power supply is an acceptable driver voltage for the load connected. (Take into account that the current used by your alarm loads have to come from the flow meter's power supply.) In either case, the voltage of the alarm output is the same as the voltage supplied to the circuit.

To use an external power supply for an isolated alarm output, connect as shown in Figure 2-15 or Figure 2-17. To use the internally powered, non-isolated alarm output connect as shown in Figure 2-16 or Figure 2-18. For a window alarm connect both outputs together.

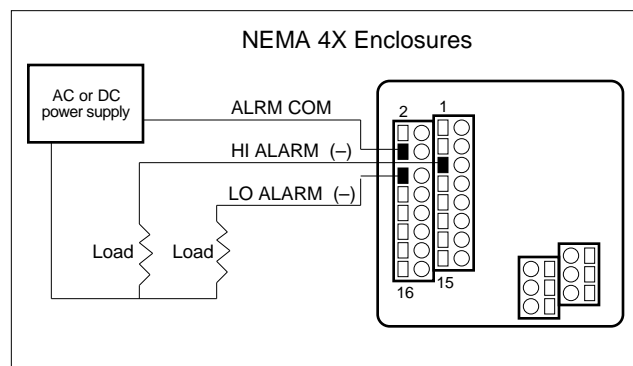

Figure 2-15. Isolated Alarm Output Connections

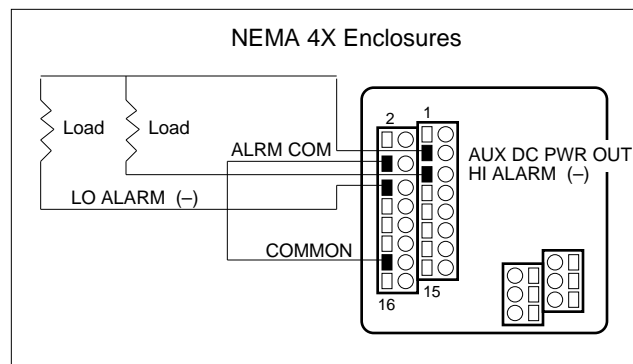

Figure 2-16. Non-Isolated Alarm Connections

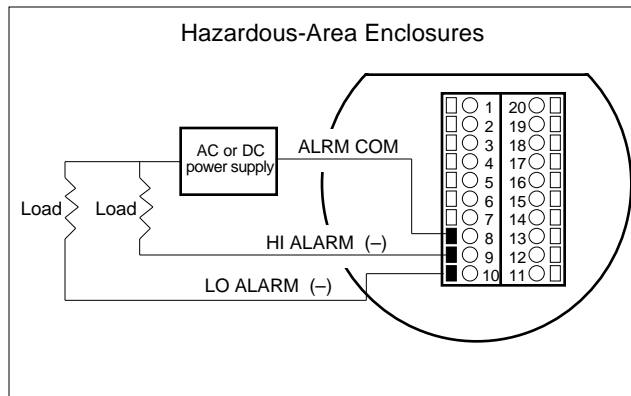

Figure 2-17. Isolated Alarm Output Connections

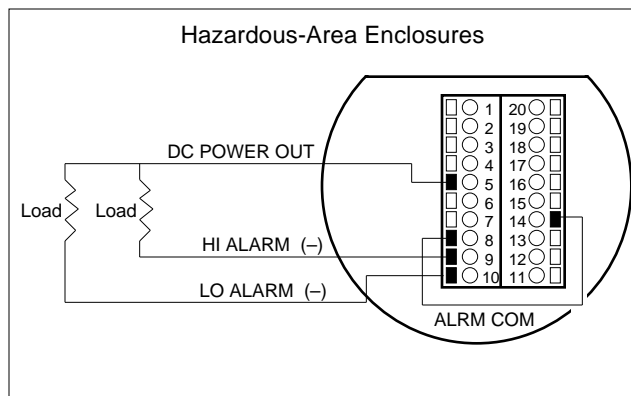

Figure 2-18. Non-Isolated Alarm Connections



Caution!

Changing the length of cables or interchanging sensors or sensor wiring will affect the accuracy of the flow meter. You cannot add or subtract wire length without returning the meter to the factory for recalibration.

Remote Sensor Probe Wiring

When connecting the sensor probe to a remotely mounted flow meter enclosure, use only factory supplied cables. The electronics, sensors and interconnecting cables supplied by Sierra Instruments are calibrated as a complete precision mass flow circuit.

To connect the sensor probe to a remotely mounted electronics enclosure, see Figure 2-19 or Figure 2-21. To make wiring connections from a sensor probe junction box to a remotely mounted enclosure, see Figure 2-20 or Figure 2-22.

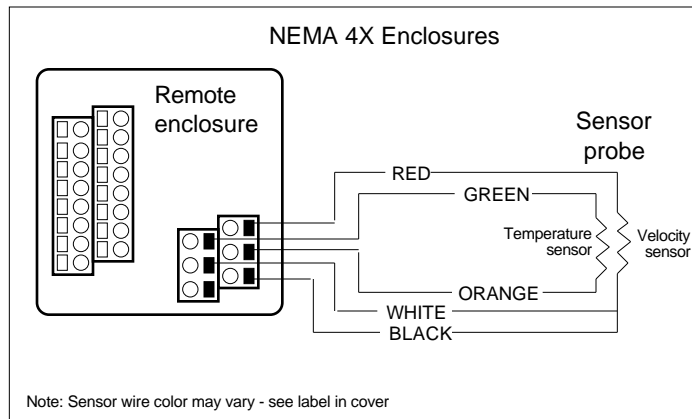

Figure 2-19. Remote Electronics Enclosure to Sensor Connections

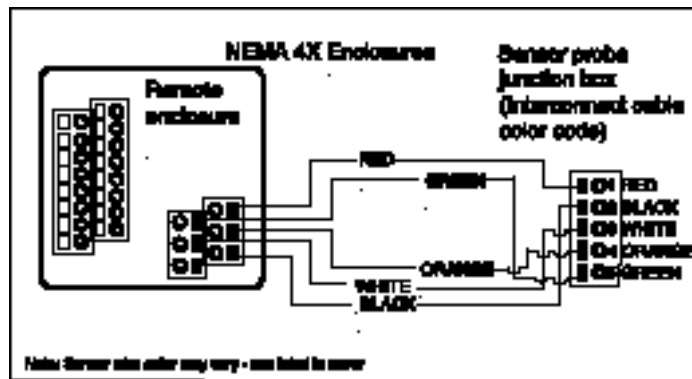

Figure 2-20. Sensor Junction Box to Remote Enclosure Connections

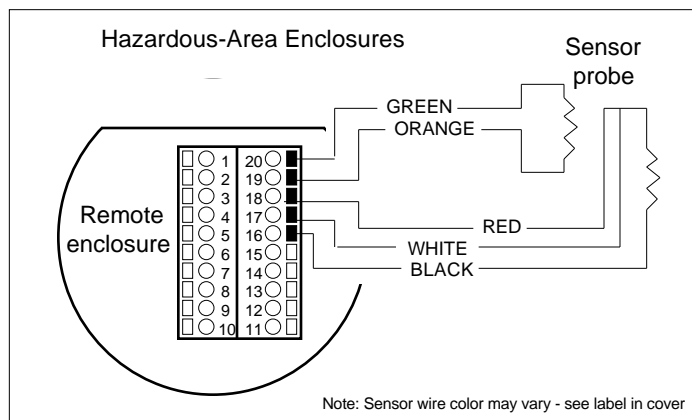

Figure 2-21. Remote Electronics to Sensor Connections

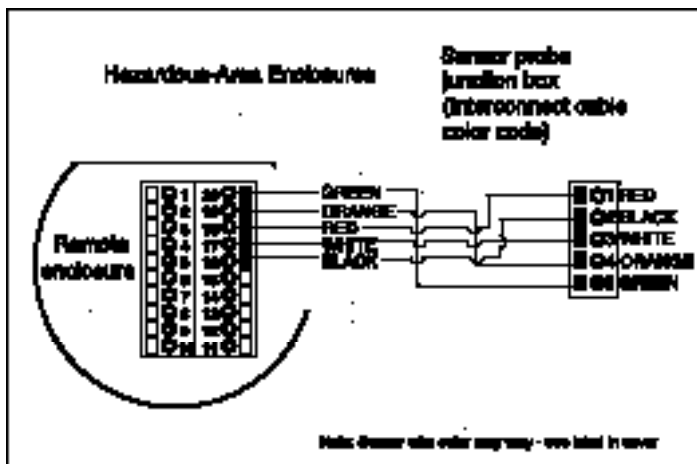

Figure 2-22. Sensor Junction Box to Remote Enclosure Connections

Range Selection Wiring

To access range selection, connect two wires on the terminal strip as shown below. When the switch is closed the device changes to Range 2. Opening the switch returns the device to Range 1.

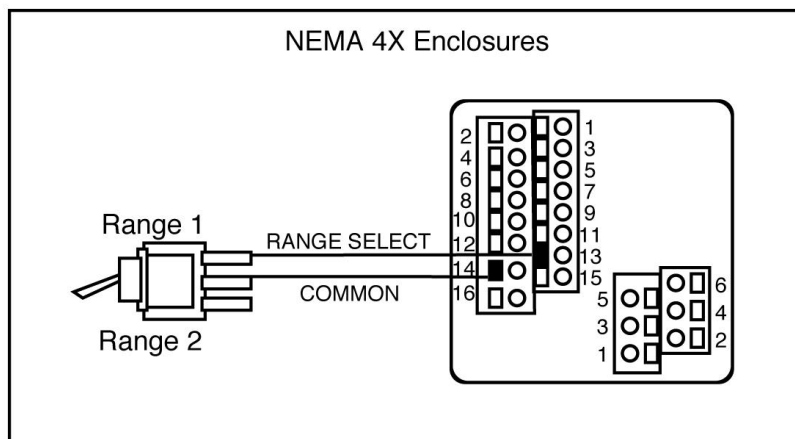

Figure 2-23. Range Selection Wiring

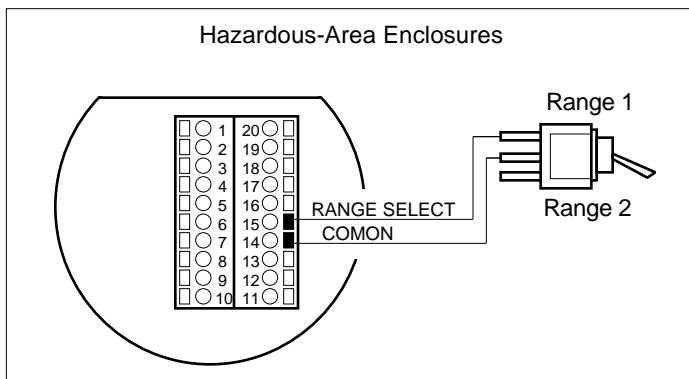

Figure 2-24. Range Selection Wiring

Chapter 3 Operation

This chapter covers flow meter operation, programming and instrument validation procedures. All instructions include directions for using either the optional LCD display or the internal Smart electronics device for programming. If your meter is not equipped with the optional display, you will need a good quality digital voltmeter or multimeter for programming and validation procedures.

Flow Meter Start Up

When applying power to a flow meter equipped with the optional LCD display you will see the product name, the software version, unit serial number, the range number, the user full scale (UFS), the current flow rate and the totalized flow. Any active alarm will flash on the screen every few seconds.

When applying power to a flow meter without the display, the Smart electronics on-board single-digit LED flashes the revision number of the software in a series of 3 digits followed by the range number. The range number continues to flash every three seconds thereafter.

Record Factory-Set Parameters

You may view parameters using the optional LCD front panel display or by selecting functions on the single-digit LED and viewing the meter's 0-5 VDC output with a digital voltmeter (DVM).

For meters with the LCD display, use a hand-held magnet or the device buttons to select the FUNCTION key. When FUNCTION is selected, the display prompts for a password. Select FUNCTION again to skip the password to view and record the factory settings. To make changes, at the password prompt use the UP arrow until the number 11 is displayed. Select FUNCTION again to continue.

For flow meters without the display, remove the enclosure cover to access the Smart electronics device. Connect the DVM as described on the following pages and record the factory-set parameters.

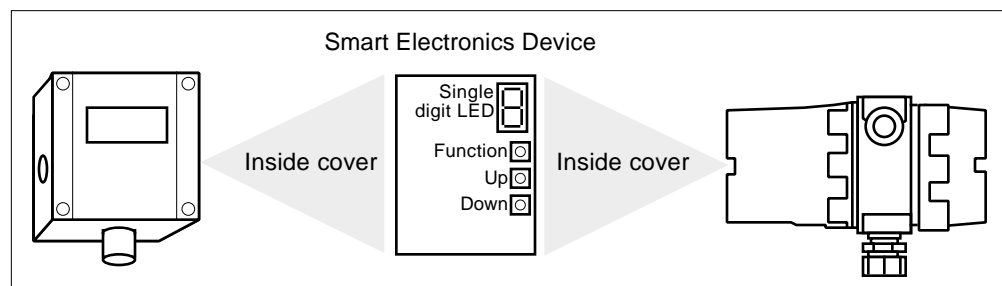

Figure 3-1. Smart Electronics Device Locations

Using the Smart Electronics Basic Features

This section covers the basic features of the Smart electronics and includes instructions on:

- entering alarm parameters
- changing the user full scale
- adjusting the K-factor
- adjusting the time response speed
- resetting the totalizer

To access the meter's advanced features of zero and span, turn to page 3-11. Instrument validation procedures begin on page 3-13.

Note: when programming the instrument, after 12 seconds of non-activity the meter returns to the Run Mode with any new settings immediately in effect. For units without a display, if the unit "times-out" press the FUNCTION button *only* to resume adjustments.

Hazardous-Area Enclosure Optional LCD Display

For units with the optional display, you may program the meter without opening the enclosure using the magnetic switches to enter the desired system settings.

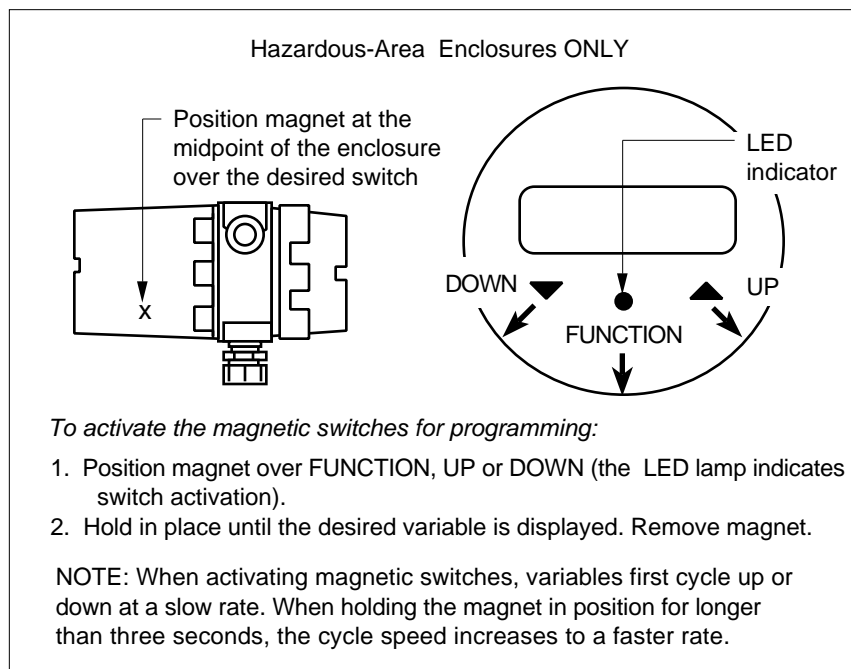

Figure 3-2. Magnetic Switch Operation



Caution!

Before making any adjustment to the Smart electronics device, verify the flow meter is not actively monitoring or reporting to any master control system. Any adjustment to the electronics will cause direct changes to flow control settings.

LCD Display Programming Menu

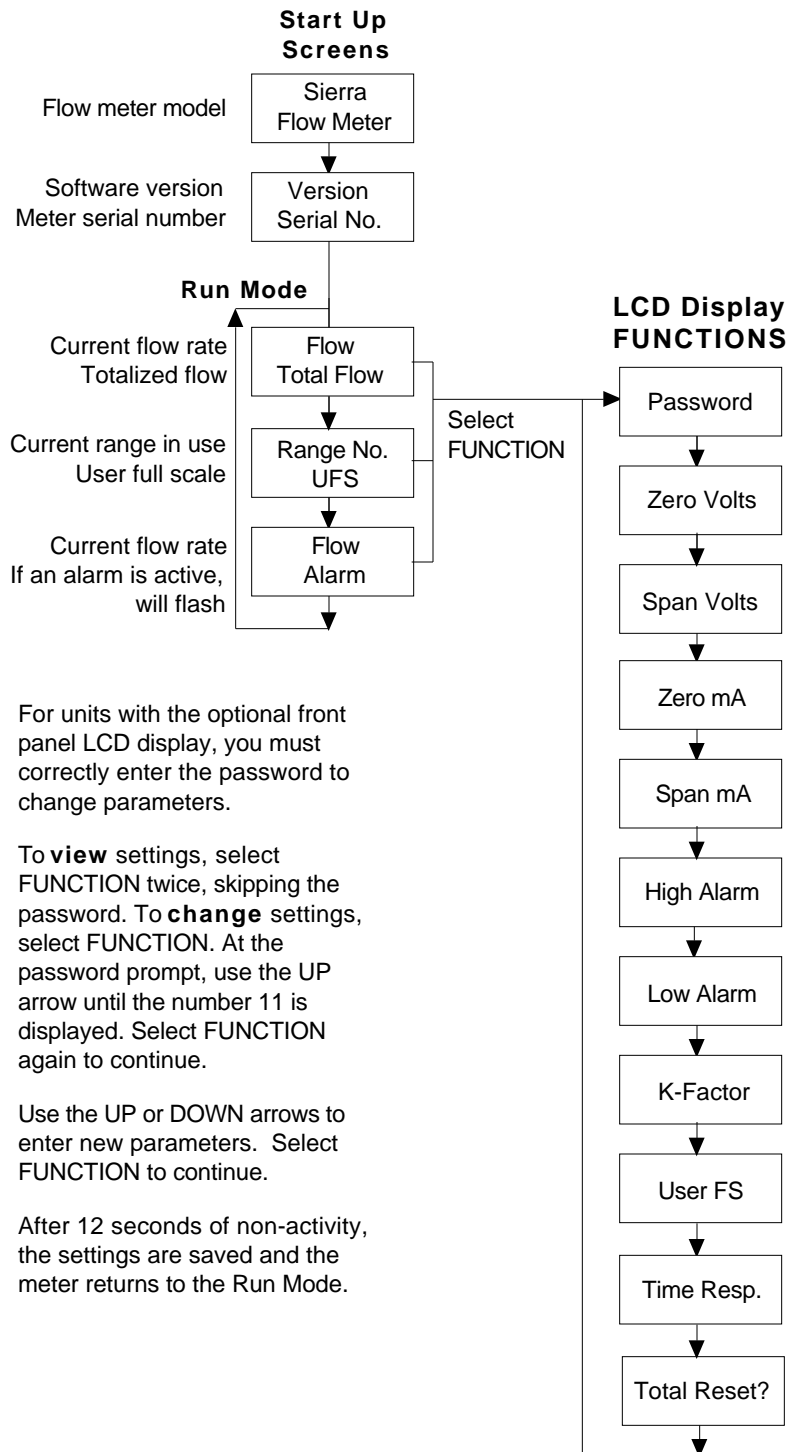

Single-Digit LED Programming Menu

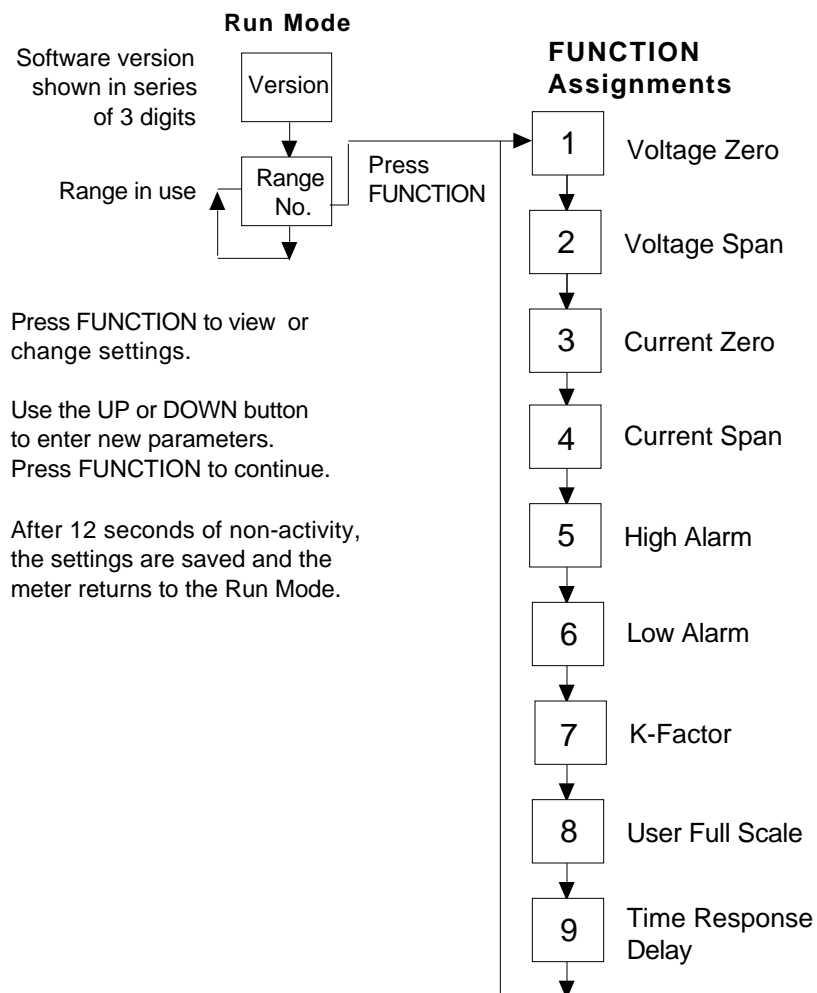

Entering Alarm Parameters



Caution!

The flow meter must not be reporting or measuring gas flow during adjustments.

Use the High Alarm and Low Alarm function to set or adjust alarm trip points. The alarms have a minimum hysteresis of 3% to avoid "chattering." When setting a window alarm, the alarm setpoints must be at least twice the hysteresis value apart. We suggest at least a 10% separation between window alarm setpoints. If you choose not to use the high alarm for a specific alarm function, Sierra recommends that you set the high alarm at 100% of the user full scale setting which creates an "over-range" indicator. Your flow meter will continue to indicate flow and generate a signal if the flow is over the maximum range, but will not operate within the specified accuracy.

Entering Alarms using the LCD Display

Enter alarms setpoints directly in engineering units.

1. Select the desired range. Select FUNCTION, enter the password. Select FUNCTION again until *High Alarm* or *Low Alarm* appears on the display.
2. Use UP or DOWN to enter the high or low alarm setpoint value in engineering units.
3. Select FUNCTION to advance to the next option, or after 12 seconds of non-activity the meter returns to the Run Mode and the new parameters are in effect.

Entering Alarms using the Single-Digit LED

When using a DVM to set alarms, the setpoint is a percentage of the flow meter's user full scale.

$$\text{VOLTS} = (\text{ALARM PERCENT} \times 5.0)$$

If you want to alarm at 25% of user full scale, used in Step 3 below, press the UP or DOWN button until 1.25 VDC is present on the DVM. If you want to alarm at 75% of user full scale, press the UP or DOWN button until 3.75 VDC is present on the DVM.

1. Set the DVM to voltage mode and connect between Vout+ and Vout- on the flow meter terminal block.
2. Select the desired range. Press the FUNCTION button until a solid "5" (high alarm) or solid "6" (low alarm) appears on the LED.
3. Adjust the UP or DOWN button until the DVM indicates the desired setpoint voltage as described above.
4. Press FUNCTION again to advance to the next option, or after 12 seconds of non-activity the meter returns to the Run Mode and the new alarm parameters are in effect.

K-Factor Adjustment

Entering a K-factor adjusts the meter's output signal without affecting the factory calibration curve. Use the K-factor calibration offset for *additional* flow profile compensation (the factory includes an initial flow profile correction in the calibration curve of the unit).



Caution!

The flow meter must not be reporting or measuring gas flow during adjustments.

Entering a K-factor using the LCD Display

A K-factor value of 1.000 means the output value is not affected and is the factory default setting. You may enter any number from 0.500 to 5.000.

1. Select the desired range. Select FUNCTION, enter the password. Select FUNCTION again until *K-factor* appears on the display.
2. Use UP or DOWN to enter the desired K-factor value in engineering units.
3. Select FUNCTION to advance to the next option, or after 12 seconds of non-activity the meter returns to the Run Mode and the new K-factor is in effect.

Entering K-factor using the Single-Digit LED

A K-factor value of 1.000 VDC means the output value is not affected and is the factory default setting. You may enter any value from 0.500 to 5.000 VDC in Step 3 below. If the device indicated output is 3.0 VDC and you know it should be 3.8 VDC then you could “force” the output to the desired 3.8 VDC by adjusting the K-factor to indicate 1.27 VDC ($1.27 = 3.8/3.0$). Use this formula to determine the desired K-factor voltage:

$$\text{VOLTS} = \text{DESIRED} / \text{INDICATED}$$

1. Set the DVM to voltage mode and connect between Vout+ and Vout– on the flow meter terminal block.
2. Select the desired range. Press the FUNCTION button until a solid “7” appears on the LED.
3. Adjust the UP or DOWN button until the DVM indicates the desired K-factor value as described above.
4. Press FUNCTION to advance to the next option, or after 12 seconds of non-activity the meter returns to the Run Mode and the new K-factor is in effect.

**Caution!**

The flow meter must not be reporting or measuring gas flow during adjustments.

User Full Scale Adjustment

The user full scale (UFS) feature adjusts the flow meter output range anywhere within 50% to 100% of the factory full scale (FFS). This feature allows you to re-range the voltage or current output of the meter to accommodate different flow rates. Note: when entering a new user full scale setting for Range 2, it cannot be less than 10% of the Range 1 user full scale.

Changing the User Full Scale using the LCD Display

The factory full scale is shown on the flow meter label. If you want a UFS equal to the FFS, adjust the display to match the FFS. If you want to use 50% of FFS, adjust the display to read 50% of the FFS.

1. Select the desired range. Select FUNCTION, enter the password. Select FUNCTION again until *User Full Scale* appears on the display.
2. Use UP or DOWN to enter the desired UFS value in engineering units.
3. Select FUNCTION to advance to the next option, or after 12 seconds of non-activity the meter returns to the Run Mode and the new UFS is in effect.

Changing the User Full Scale using the Single-Digit LED

If the FFS is set to 11,000 sfpm and UFS is set to output 5.0 VDC, or 100%, the flow meter will indicate 5.0 VDC when 11,000 sfpm is present on the probe. If you want 6,000 sfpm for UFS, used in Step 3 below, adjust the UFS to 6000/11000 or 54.55% of factory full scale. Adjust the voltage to 2.73 VDC ($2.73 = 5 \times .5455$). Use this formula to determine the desired UFS voltage:

$$\text{VOLTS} = 5 \times \text{User Full Scale} / \text{Factory Full Scale}$$

1. Set the DVM to voltage mode and connect between Vout+ and Vout- on the flow meter terminal block.
2. Select the desired range. Press the FUNCTION button until a solid “8” appears on the LED.
3. Adjust the UP or DOWN button until the DVM indicates the desired user full scale as described above.
4. Press FUNCTION to advance to the next option, or after 12 seconds of non-activity the meter returns to the Run Mode and the new UFS is in effect.

Time Response Delay Adjustment

Changing the Time Response Delay using the LCD Display

1. Select FUNCTION, enter the password. Select FUNCTION again until *Time Response* appears on the display.
2. Use UP or DOWN to adjust the time response delay from 0.10 to 7.2 seconds.
3. Select FUNCTION again to advance to the next option, or after 12 seconds of non-activity the meter returns to the Run Mode and the new time response setting is in effect.

Changing the Time Response Delay using the Single-Digit LED

1. Set the DVM to voltage mode and connect between Vout+ and Vout– on the flow meter terminal block. Select the desired range. Press the FUNCTION button until a solid “9” appears on the LED.
2. Adjust the UP or DOWN button until the DVM indicates the desired voltage (as shown in the following table).

Volts Indicated on DVM	Time Response (Seconds)	Volts Indicated on DVM	Time Response (Seconds)	Volts Indicated on DVM	Time Response (Seconds)	Volts Indicated on DVM	Time Response (Seconds)
0.5	0.1	1.0	0.3	1.5	0.5	2.0	0.7
2.5	1.2	3.0	1.8	3.5	2.4	4.0	3.6
4.5	4.8	5.0	7.2				

3. Press FUNCTION to advance to the next option, or after 12 seconds of non-activity the meter returns to the Run Mode and the new time response delay setting is in effect.

Totalizer Reset

If your device is equipped with the optional LCD display, reset the totalizer using the magnetic switches or device buttons. If you are unable to open the flow meter enclosure, use a magnet to reset the totalizer as shown below.

Reset the Totalizer using the LCD Display

1. Select the desired range. Select FUNCTION, enter the password. Select FUNCTION again until *Total Reset?* appears on the display.
2. Select the UP button and then the DOWN button until the display reads “Resetting Totalizer.”

Reset the Totalizer without Opening the Enclosure

1. Position a magnet above the enclosure until the display reads “Resetting Totalizer.”

For Hazardous-Area enclosures only: To disable the magnetic reset function of the totalizer, remove jumper (J2) from the PCB at the location shown below. (You may not disable the magnetic reset switch on NEMA 4X enclosures.)

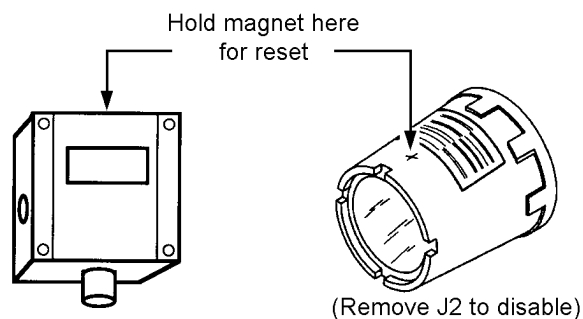

**Caution!**

Adjusting zero or span will affect meter calibration.

Using the Smart Electronics Advanced Features

Zero and span (Function 1 through 4) can be used to validate system operation and calibrate the digital to analog signals on the Smart electronics device. Additionally, these functions can compensate for resistance in long signal cables connected to your data collection or indicating system.

You must use a certified digital voltmeter to adjust zero and span as the voltmeter acts as a standard. We recommend recording the current values as shown on the LCD display or DVM before making any changes to the zero and span settings. Note: when adjusting zero the voltage signal will be driven to 0 VDC and when adjusting span the voltage signal will be driven to 5 VDC (or 10 VDC).

Voltage Zero Adjustment

If needed, use Zero Volts (Function 1) to adjust the 0-5 VDC output to 0.0 VDC, or optional 0-10 VDC to 0.0 VDC.

1. Set the DVM to voltage mode and connect between Vout+ and Vout-.
2. Select FUNCTION, enter the password (if so equipped). Select FUNCTION again until *Zero Volts* appears on the LCD display or a solid “1” appears on the LED. Adjust UP or DOWN until the DVM indicates between 0 and .01 VDC (no less than 0.005, the Smart electronics device cannot drive negative values).
3. After 12 seconds of non-activity, the meter returns to the Run Mode and the new parameter is in effect.

Voltage Span Adjustment

If needed, use Span Volts (Function 2) to adjust the 0-5 VDC output to 5.0 VDC, or optional 0-10 VDC to 10 VDC.

1. Set the DVM to voltage mode and connect between Vout+ and Vout-.
2. Select FUNCTION, enter the password (if so equipped). Select FUNCTION again until *Span Volts* appears on the LCD display or a solid “2” appears on the LED. Adjust UP or DOWN until the DVM, indicates between 4.99 and 5.01 VDC. (For 0-10 VDC devices, the target value is 9.99 to 10.01.)
3. After 12 seconds of non-activity, the meter returns to the Run Mode and the new parameter is in effect.

Note: when adjusting zero the current signal will be driven to 4 mA and when adjusting span the current signal will be driven to 20 mA. We recommend recording the current values before making any changes to the current zero or span settings.

Current Zero Adjustment

If needed, use Zero mA (Function 3) to adjust the 4-20 mA output to 4.0 mA.



Caution!

Adjusting zero or span will affect meter calibration.

1. Disconnect the 4-20 mA (+) loop wire. Set the DVM to current mode and connect the positive lead to the wire you just disconnected. Connect the negative lead to the 4-20 mA (-) on the flow meter terminal block.
2. Select FUNCTION, enter the password (if so equipped). Select FUNCTION again until *Zero mA* appears on the LCD display or a solid “3” appears on the LED. Adjust UP or DOWN until the DVM indicates between 3.95 and 4.05 mA. Set DVM back to voltage mode when adjustment is complete.
3. After 12 seconds of non-activity, the meter returns to the Run Mode and the new parameter is in effect.

Current Span Adjustment

If needed, use Span mA (Function 4) to adjust the 4-20 mA output to 20.0 mA.

1. Disconnect the 4-20 mA (+) loop wire. Set the DVM to current mode and connect the positive lead to the wire you just disconnected. Connect the negative lead to 4-20 (-) on the flow meter terminal block.
2. Select FUNCTION, enter the password (if so equipped). Select FUNCTION again until *Span mA* appears on the LCD display or a solid “4” appears on the LED. Adjust UP or DOWN 2 until the DVM indicates between 19.95 and 20.05 mA. Set DVM back to voltage mode when adjustment is complete.
3. After 12 seconds of non-activity, the meter returns to the Run Mode and the new parameter is in effect.

Instrument Validation

System electronics are verified by injecting a known input value and confirming that the flow meter outputs the expected value. This test confirms that the microprocessor, analog to digital and digital to analog converters, the linearizer and the display are working properly. Sensor validation is accomplished by measuring the resistance of the velocity and temperature sensors and comparing the results to the NIST-traceable calibration data provided with the flow meter. These tests confirm that your meter is working correctly and the calibration variables did not drift, shift or change values.

To perform the instrument validation procedures you will need the following equipment:

- certified digital multimeter with minimum 4 character resolution, accuracy of at least $\pm 0.1\%$ of range
- Calibration Certificate supplied with the flow meter
- small pot adjusting tool (screwdriver)

Before beginning the validation procedures, review Figure 3-3 and Figure 3-4 to familiarize yourself with the component locations.

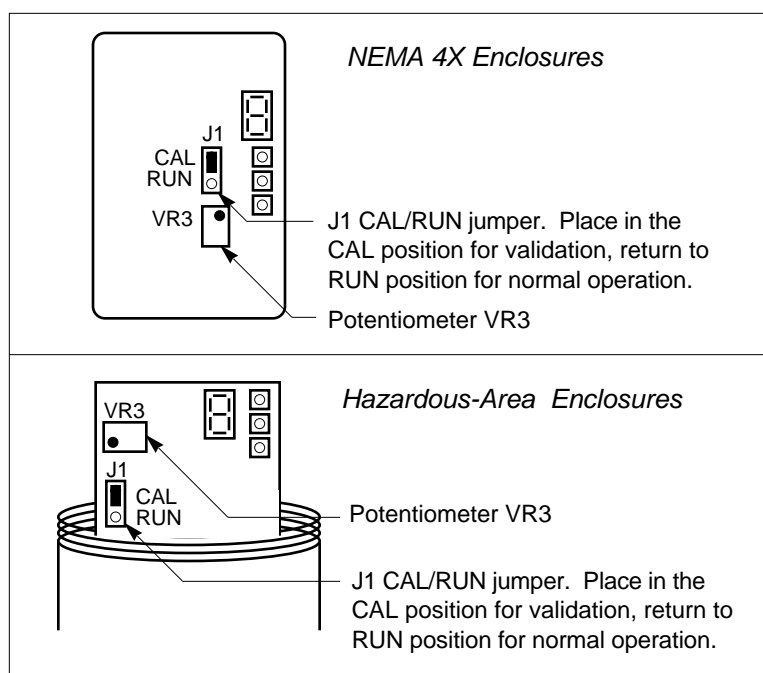

Figure 3-3. Electronics Validation Component Locations

Electronics Validation Procedure

**Caution!**

Before beginning this procedure, make sure the flow meter is not actively monitoring or reporting to any master control system. Any adjustment to the electronics will cause direct changes to flow control settings.

1. Verify the flow meter is off line from any remote communications. Make sure the meter's user full scale setting is the same as the factory full scale setting. If not, adjust the user full scale value as needed.
2. Locate the Calibration Certificate supplied with the flow meter. Record in Table 3-1 the five bridge voltage values, the output (VDC or mA) values and the indicated flow values.
3. Remove power from the flow meter. Remove the cover(s) of the flow meter enclosure to access the wiring terminal block and the Smart electronics device.
4. Set the multimeter to the 20 volt range. Connect to BV(+) and BV(-) terminals on the flow meter terminal block.
5. Move the J1 Cal/Run jumper on the Smart electronics device to the CAL position. Locate potentiometer VR3 on the Smart electronics device. Turn on power to the flow meter.
6. Adjust potentiometer VR3 until the multimeter matches the first bridge voltage point (the value must be ± 0.002 VDC of the bridge voltage point).
7. Record the resulting flow shown on the optional LCD display in Table 3-1. If not using a display or if you prefer to validate one of the analog output signals, move the multimeter + connection to Vout (+). Record the resulting output voltage in Table 3-1. If using a 4-20 mA calibrated meter, set the multimeter to read current and connect the meter to read the mA signal in your connected loop. Record the resulting current output in Table 3-1.
8. Repeat Step 6 and Step 7 to record the results of the remaining four bridge voltage validation points in Table 1. Compare the values recorded in Table 3-1. Indicated values must be within the flow meter's stated accuracy shown on the Calibration Certificate.
9. When data collection is complete, turn off power to the flow meter. Disconnect the multimeter from the flow meter terminal block.
10. Place the J1 Cal/Run jumper in the RUN position. Make sure the jumper is securely in place before resuming flow meter operation. Replace the flow meter cover(s).

Calibration Certificate Values				Validation Test Results			
Sample Point	Bridge Voltage	Indicated Flow	Output (V or mA)	Indicated Flow (LCD)	Flow Meter Stated Accuracy	Output (V or mA)	Flow Meter Stated Accuracy
0%							
25%							
50%							
75%							
100%							

Table 3-1. Electronics Validation Results

Sensor Validation Procedure

1. Locate the Ro temperature (measured resistance at 0°C) value and the Alpha value shown on the Calibration Certificate supplied with the flow meter.
2. **Turn off power to the flow meter. Allow a 6 minute cool-down before continuing.**
3. Remove the cover of the flow meter enclosure to access the sensor connection points. Remove the four-position jumper from J5, J6, J7 and J8 (see below for location).



Warning!

Do not power the flow meter with the sensor jumper disconnected. This could cause overheating of the sensors and/or damage to the electronics.

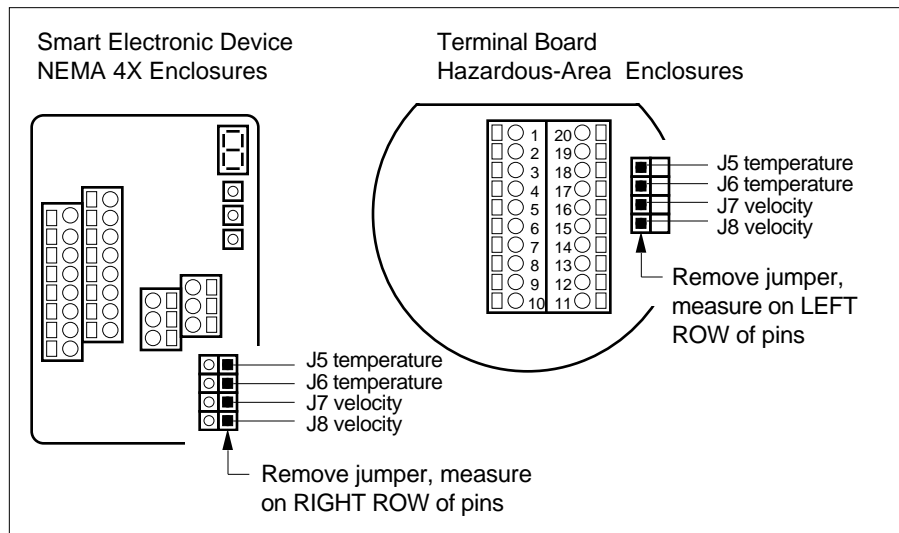

Figure 3-4. Sensor Validation Component Locations

4. Set the multimeter to read Ohms in the 2K range. Connect the multimeter to the terminals of J5 and J6 (temperature sensor). Measure the resistance between J5 and J6 and record the temperature sensor resistance (in Ohms) in Table 3-2.
5. Set the multimeter to read in the 200 Ohm range. Connect the multimeter to terminals of J7 and J8 (velocity sensor). Measure the resistance between J7 and J8 and record the velocity sensor resistance (in Ohms) in Table 3-2.
6. Use the measured resistance values and the R_0 and Alpha R_0 values from the Calibration Certificate to calculate the temperature for each sensor as follows:

$$T = \frac{R - R_0}{\text{Alpha} \times R_0}$$

Where

T = degrees Celsius

R = measured sensor resistance

R_0 = resistance at 0° C (from the Calibration Certificate)

Alpha = value unique to each sensor (from the Calibration Certificate)

7. Compare the results recorded in Table 3-2. The sensors are validated if they are within 10 degrees Celsius of each other.
8. Disconnect the multimeter and replace the four-position jumper on the sensor terminals. **Make sure the jumper is securely in place before applying power.** Replace cover.

Temperature Sensor Resistance	T (from equation)
Velocity Sensor Resistance	T (from equation)

Table 3-2. Sensor Validation Results

Chapter 4 Troubleshooting and Repair

Troubleshooting the Flow Meter

**Warning!**

Before attempting any flow meter repair, verify that the line is not pressurized.

Always remove main power before disassembling any part of the mass flow meter.

Begin hardware troubleshooting by verifying the following facilities issues are correct. These areas impact system operation and must be corrected prior to performing any flow meter inspections.

1. Verify the incoming power to the flow meter is present and of the correct voltage and polarity.
2. Check the flow meter wiring for correct connections as described in Chapter 2.
3. Verify the flow meter is installed with the correct number of upstream pipe diameters as shown on page 2-2.
4. Verify the flow direction indicator is correctly aligned pointing downstream of flow.
5. Make sure there are no leaks in the line being measured.

After verifying the factors above, follow the troubleshooting procedures outlined on the next page. If you need to return the flow meter to the factory, see page 4-3 for return shipping instructions.

Flow Meter Calibration

Sierra Instruments maintains a fully-equipped calibration laboratory. All measuring and test equipment used in the calibration of Sierra meters are traceable to NIST standards. Sierra is ISO-9001 registered and conforms to the requirements of ANSI/NCSL-Z540 and ISO/IEC Guide 25. If the flow body or electronics have been damaged or you simply want to have the flow meter re-calibrated, contact the factory for return shipping instructions. Calibration must be performed by qualified personnel using NIST-traceable equipment.

Problem	Possible Cause	Solution
Velocity measurement is erratic or fluctuating	Very erratic or non-uniform flow	Follow installation requirements shown in Chapter 2
	Moisture present in gas flow	Install a water trap or filter upstream of the flow meter sensor
	Flow conditioning plates are not upstream of the sensor	Correct flow meter orientation
	Sensor component broken	Return to factory for replacement
	Malfunction in system electronics	Return to factory for evaluation
	Ground loop	Check wiring, see Chapter 2
Velocity measurement seems too high or low	Sensor assembly not aligned correctly to flow	Correct alignment with the flow indicator pointing downstream in the direction of flow
	Flow conditioning plates are not upstream of the sensor	Correct flow meter orientation
No response to flow from sensor assembly	No power	Turn on power to the flow meter
	Low flow cutoff setting too high	Correct low flow cutoff programming using the Smart Interface software.
	Flow rate below meter's minimum flow rating	Contact factory for instructions
	Flow has exceeded the maximum range of the flow meter	Set the user full scale to equal the factory full scale Reduce flow below the maximum range shown on the meter's nameplate or contact the factory for re-calibration advice
	Sensor failure	Return to factory for evaluation
	Printed circuit assembly defective	Return to factory for evaluation

Returning Equipment to Factory

Before returning any mass flow meter to the factory, you must request and complete a Sierra Calibration/Repair Data Sheet. To obtain the data sheet contact Customer Service at:

(800) 866-0200 or (831) 373-0200 in the US
or +31(0)20-6145810 in Europe.

Return shipments to:

USA Headquarters
Sierra Instruments Service Department
5 Harris Court, Building W
Monterey, CA 93940

European Headquarters
Sierra Instruments b.v. Service Department
Bolstoen 30A
1046 AV Amsterdam, The Netherlands

When returning a component, make sure to include the completed Calibration/Repair Data Sheet with the shipment.

Appendix A Product Specifications

Performance Specifications

Accuracy	± 2% of reading from 10 to 100% of calibrated range ± 0.5% of full scale below 10% of calibrated range
Repeatability	± 0.2% of full scale
Temperature Coefficient	± 0.02% of reading per °F within ± 50°F of customer specified conditions ± 0.03% of reading per °F within ± 50°F to 100°F of customer specified conditions ± 0.04% of reading per °C within ± 25°C of customer specified conditions ± 0.06% of reading per °C within ± 25°C to 50°C of customer specified conditions
Pressure Coefficient	Negligible when within ± 50 psig (± 3.4 barg) of customer specified conditions
Response Time	One second to 63% of final velocity value

Operating Specifications

Gases Most gases compatible with 316L stainless steel (consult factory)

Mass Flow Rates

Pipe Size	Air Flow Ranges ⁽¹⁾			
	Minimum		Maximum ^{(2),(3)}	
	scfm	(nm ³ /hr)	scfm	(nm ³ /hr)
1/4-inch	0–0.5	(0–0.7)	0–9	(0–14)
1/2-inch	0–2	(0–3.0)	0–40	(0–60)
3/4-inch	0–4	(0–5.9)	0–75	(0–120)
1-inch	0–6	(0–8.9)	0–120	(0–180)
1 1/2-inch	0–15	(0–22)	0–280	(0–440)
2-inch	0–23	(0–33)	0–470	(0–680)
3-inch	0–50	(0–74)	0–1000	(0–1500)
4-inch	0–90	(0–130)	0–1800	(0–2700)
6-inch	0–200	(0–300)	0–4000	(0–5900)
8-inch	0–350	(0–520)	0–7000	(0–10,000)

- Notes:
- (1) Flow rates for air and nitrogen. Standard conditions: 70°F and one atmosphere for scfm; 0°C and one atmosphere for nm³/hr. Consult factory for other gases.
 - (2) Higher flow ranges available, consult factory.
 - (3) Maximum flow rates are limited for hazardous area and high temperature versions, consult factory.

Dual Calibration	User-selectable dual ranges or two different gases
Gas Pressure	150 lb flange or PN16 DIN (–40° F to 100° F): 230 psig (15.9 barg) maximum 150 lb flange or PN16 DIN (250° F): 185 psig (12.8 barg) maximum 150 lb flange or PN16 DIN (450° F): 155 psig (10.7 barg) maximum NPT (–40° F to 450° F): 500 psig (34 barg) maximum, 5 to 150 psig (0.3 barg to 10 barg) optimum
Gas & Ambient Temperature	Gas.....–40° to 250°F (–40° to 120°C) Optional –40° F to 450° F (–40° C to 230° C) not available on 1/4 and 1/2-inch flow bodies Ambient.....–5° to 120°F (–20° to 50°C)

Leak Integrity	1 X 10 ⁻⁴ atm cc/sec of helium maximum
Power Requirements	18 to 30 VDC (regulated), 625 mA maximum 100 to 240 VAC , 50/60 Hz, 15 watts maximum* <small>*not available on NEMA 4X enclosures</small>
Output Signal	Linear 0-5 VDC or 0-10 VDC proportional to mass flow rate, 1000 Ohms minimum load resistance, or Linear 4-20 mA proportional to mass flow rate, 700 Ohms maximum resistance (power supply dependent), optically isolated
Alarms	User-adjustable low, high or window alarms Deadband adjustable with Smart Interface™ software Relay rating.....Maximum 42 VAC or 42 VDC, 140 mA
Displays	Alphanumeric 2 x 12 digit backlit LCD Adjustable variables via on-board membrane buttons or with Smart Interface™ software Adjustable variables.....Full scale adjustment (50 to 100%) Time response (0.1 to 7.2 seconds) Correction factor setting (0.5 to 5) Zero and span adjustments
Totalizer	Eight digits (99,999,999) in engineering units
Software	Smart Interface Windows™-based software, minimum 8 MB of RAM, preferred 16 MB of RAM, RS-232 communication

Physical Specifications

Wetted Materials	316L stainless steel, Schedule 40 pipe flow body, Carbon steel flow bodies available in some sizes
Enclosure	Hazardous-Area enclosure (IP67) and NEMA 4X (IP65) powder-coated cast aluminum
Electrical Connections	Two 3/4 inch NPT Hazardous-Area enclosure (IP67) One 1/2 inch NPT NEMA 4X enclosure (IP65)
Certifications*	CE (all enclosures) CSA (Explosion proof for Class I, Division 1, Groups B, C, D) EEx (EEx dIIC T6...T2) Cenelec FM (Explosion proof for Class I, Division 1, Groups B, C, D) <small>*Certifications pending, contact factory</small>